

INSTRUCTIONS for Predator Model GS-1

GULLSWEEP® is made of materials that are resistant to the effects of salt water and sunlight. Arms are bright anodized aluminum and may be cleaned with a damp cloth. The bearing pin should be kept clean. Wash out the bearing hole and entire GullSweep® occasionally with fresh water.

Store **GULLSWEEP®** away when winds are in excess of 35 mph as birds will not roost in such winds, and the high rotation rate will not improve the life of the **GULLSWEEP®**.

ASSEMBLY: This **GULLSWEEP®** is pre-assembled. Follow the directions for the mounting parts (GS-4 Deck Mount) or the other non-permanent mounting accessories.

IMPORTANT: Putting **GULLSWEEP®** to work after mounting: Place **GULLSWEEP®** on center mounting pin (See Fig. 8). Notice that the mounting retainer spring is over the ring on the center hub. (The spring should not touch the hub or retainer ring.) This prevents **GULLSWEEP®** from falling off center pin in the event that it tilts over. Fold arms out to each side and take vanes out of storage position (Fig. 7A) so they snap down off center rod (Fig. 7). **Vaness must be on opposite sides of arm (Fig. 6). If you do not do this GULLSWEEP® will not work!**

MOUNTING: The **GULLSWEEP®** can be mounted on the canopy forward deck or stern deck, as shown in Fig. 1 or Fig. 2. **The bearing pin should always be vertical to the water for optimum results** (Fig. 4 & 6). If tilted, it may not work well in a light breeze. Where there are searchlights, etc., on the forward part of the canopy, or on a very large canopy, it is preferable to mount the **GULLSWEEP®** toward the stern (as in Fig. 3), since a gull generally lands into the wind. If additional clearance is needed, the arms may be bent as in Fig. 4. Or use a longer center pin (models GS-12 & GS-13). When mounting the permanent base block on wood or fiberglass, holes should be drilled first, using a 1/8" or #30 drill. (Stainless steel screws are provided.) See enclosed pamphlet for additional mounting options.

For your convenience, GullSweep now offers a storage pouch! See GS-P on parts list.

IMPORTANT - When putting your GullSweep® to work, swing vane out of storage position and it will snap down on one side of the support rod (fig. 7). If you do not do this your GullSweep® will not work! (No rotation.)

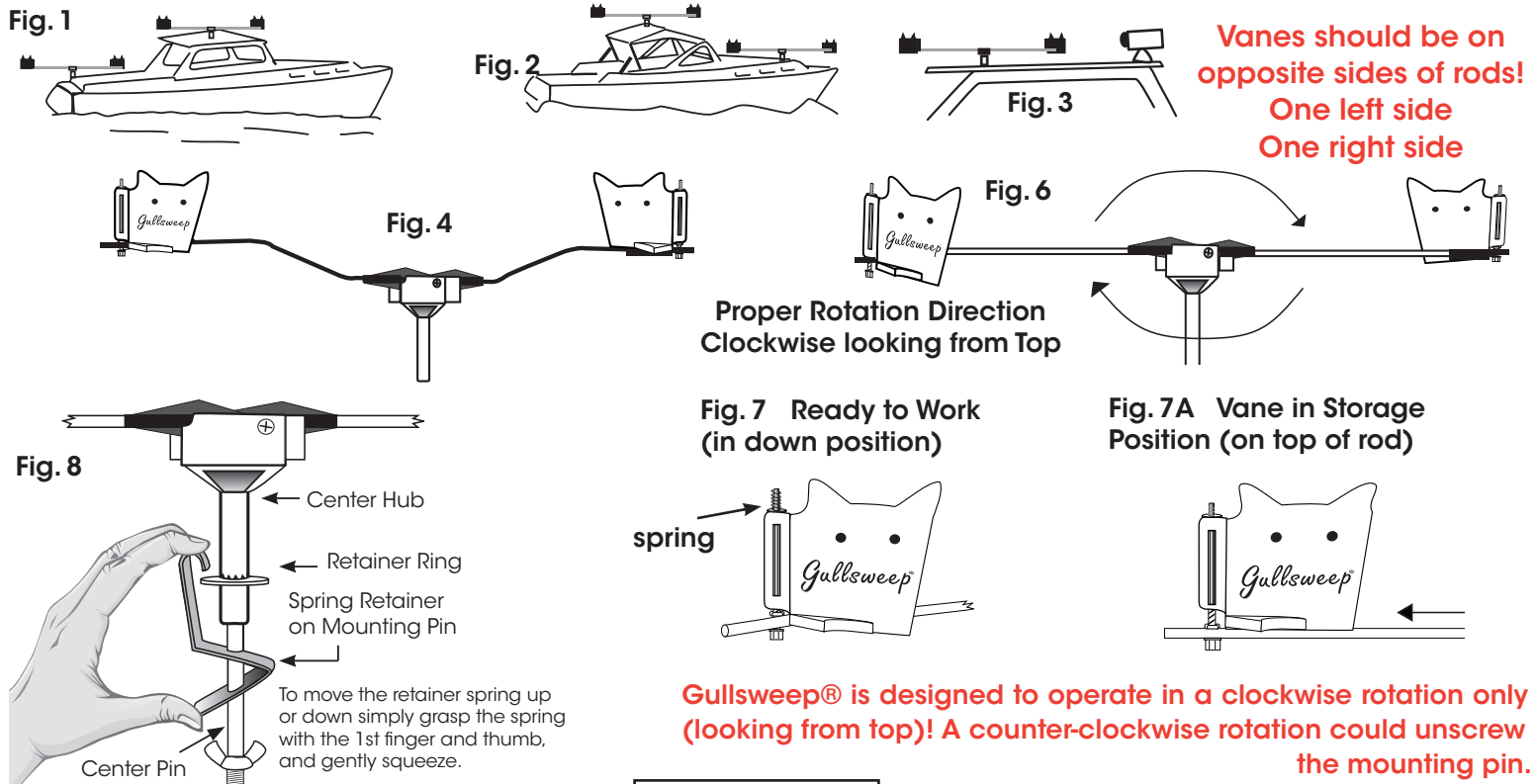

GullSweep® is designed to operate in a clockwise rotation only (looking from top)! A counter-clockwise rotation could unscrew the mounting pin.

WARNING

Boat should not be run with the GullSweep® mounted. Boat speed will only create higher GullSweep® RPM's, possibly damaging unit. One should not forget why the GullSweep® was designed - to deter gulls from roosting on

an anchored boat.

Center mounting pin should always be removed & stored when GullSweep® is not in use. Pin could be dangerous to boat passengers.

GS-1 MOUNTING OPTIONS

NON-PERMANENT MOUNTING: (not included)

For a non-permanent mounting option (i.e., for bimini, T-Top, cabin or sails), select one of the following mountings. They are sold separately from **GULLSWEEP®** and utilize the standard 5-1/2" stainless steel **GULLSWEEP®** center pin (GS-6) that comes with a standard **GULLSWEEP®** (model GS-1).

Model GS-SRM for mounting on hand rail. Most frequently used rail mount. Will clamp onto 5/8" to 1" rail or pipe.

Model GS-RM for mounting on hand rail or pipe work. Will clamp up to 1-5/8" pipe (See figure 5).

Model GS-FM & GS-FMNS (Flex mount) - The GS-FM is made of heavy canvas with a sand filled center (weight 3 lbs.) and rope loops on each end. Ideal for bimini or canvas covers. The GS-FMNS is the same as GS-FM, but is not filled with sand which reduces weight and shipping costs. There is a Velcro opening to add sand, if desired.

GS-SBB - for Sailboat Boom. Can also be mounted on stored Bimini Covers. Designed like a saddle to fit over any boom or bimini bundle. To secure, tie a rope (not included, as we do not know the diameter of sail and boom).

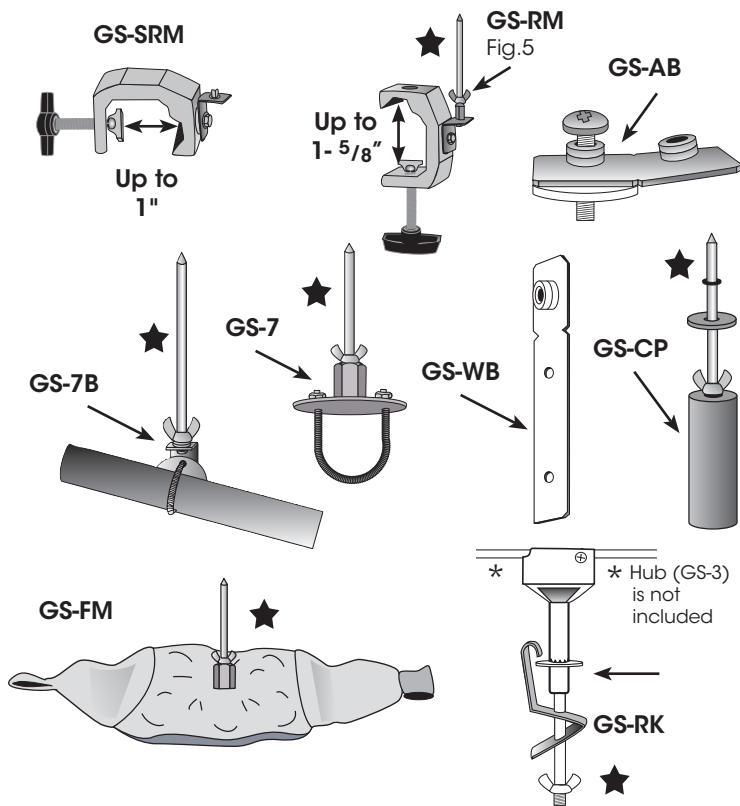

★ **CENTER PIN IS NOT INCLUDED WITH MOUNTING OPTIONS!**
(use pin that came with GS-1)

GS-1 REPLACEMENT PARTS (3' arms)

The **GULLSWEEP®** is a rugged and dependable performer; however, sometimes a new part will give your **GULLSWEEP®** new life.

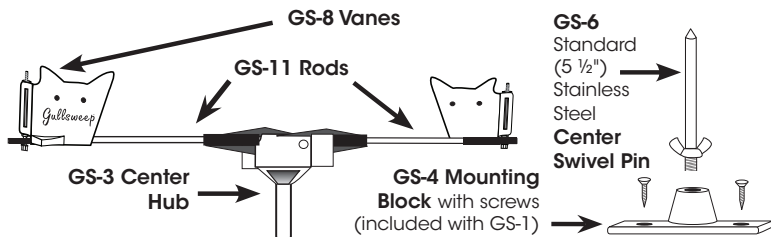

HANGING GULLSWEEP

Ideal for Sailboats

Model
HGS-1

Go to
www.gullswEEP.com
for information.

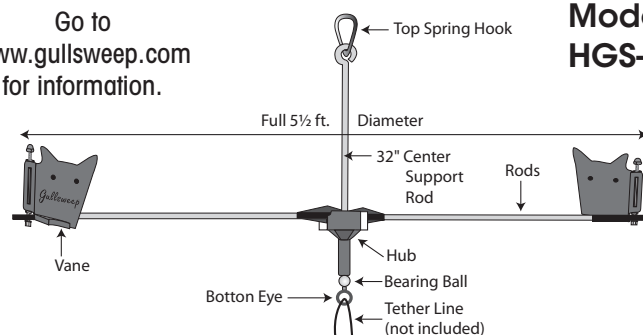

GullswEeps

GS-1	Standard GullswEEP. 3' arms, 6' diameter
GS-8ft	GullswEEP with Longer arms, 4' arms, 8' diameter
GS-4ft	GullswEEP with Shorter arms, 2' arms, 4' diameter
GS-1 mini	GullswEEP mini display or for tabletops 1' arms for 2' diameter
HGS-1	Hanging GullswEEP. 3' arms, 6' diameter
HGS-8ft	Hanging GullswEEP with Longer arms, 4' arms, 8' diameter

GullswEEP Mounting Options

GS-7	U-Bolt through canvas kit - or rail mount 1" dia.
GS-7B	90° Angle Bracket for Rail Mount - Adjust center pin to vertical
GS-AB	Adapter Bracket - to adjust center pin to vertical, can be used on GS-4 (bend to suit).
GS-WB	Stainless Steel Bracket for windshield mounting (bend bracket, to suit angle)
GS-FM	Flex Mounting - Non-Permanent, 8"x 23" sand bag type
GS-FMNS	Flex Mounting - Non-Permanent, 8 x 23, without sand
GS-FMB	Flex Mounting - Non-Permanent, 8 x 23, without sand and velcro strips on bottom
GS-SBB	Sailboat Boom - Non-Permanent to fit over any boom or bimini bundle.
GS-RM	Rail Mounting - Non-Permanent for pipe up to 1-5/8" dia.
GS-SRM	Rail Mounting - Non-Permanent for pipe up to 1" dia.
GS-CP	Plastic adapter for top of existing canvas support pole with 3/8" pin (pin included with GS-1).
GS-RK	Retainer Kit - SS Bracket, Shrink Tube, Grommet and O-ring.

STANDARD REPLACEMENT PARTS

GS-3	Center Hub Replacement
GS-4	Black Base - Mounting Block & Screws
GS-4W	White Base - Mounting Block & Screws
GS-6	Swivel Pin Replacement - Stainless Steel, Size 5-1/2" long
GS-8	Vane Set Replacement (2)
GS-11	Arm/Rod Set Replacement, 6' dia. (2) 3' long'

Optional Replacement Parts

GS-11S	Arm/Rod Set Replacement, 4' dia. (2) - 2' long
GS-12	Swivel Pin Replacement - Stainless Steel, Size 7-1/2" long
GS-13	Swivel Pin Replacement - Stainless Steel, Size 10" long

For more information on GullswEEP & mounting options visit our website; www.gullswEEP.com