



Compliant with ISO, DIN, and JIS standards



NEW

High-Speed, Compact Caged Ball Screw

SDA-V/SDAN-V

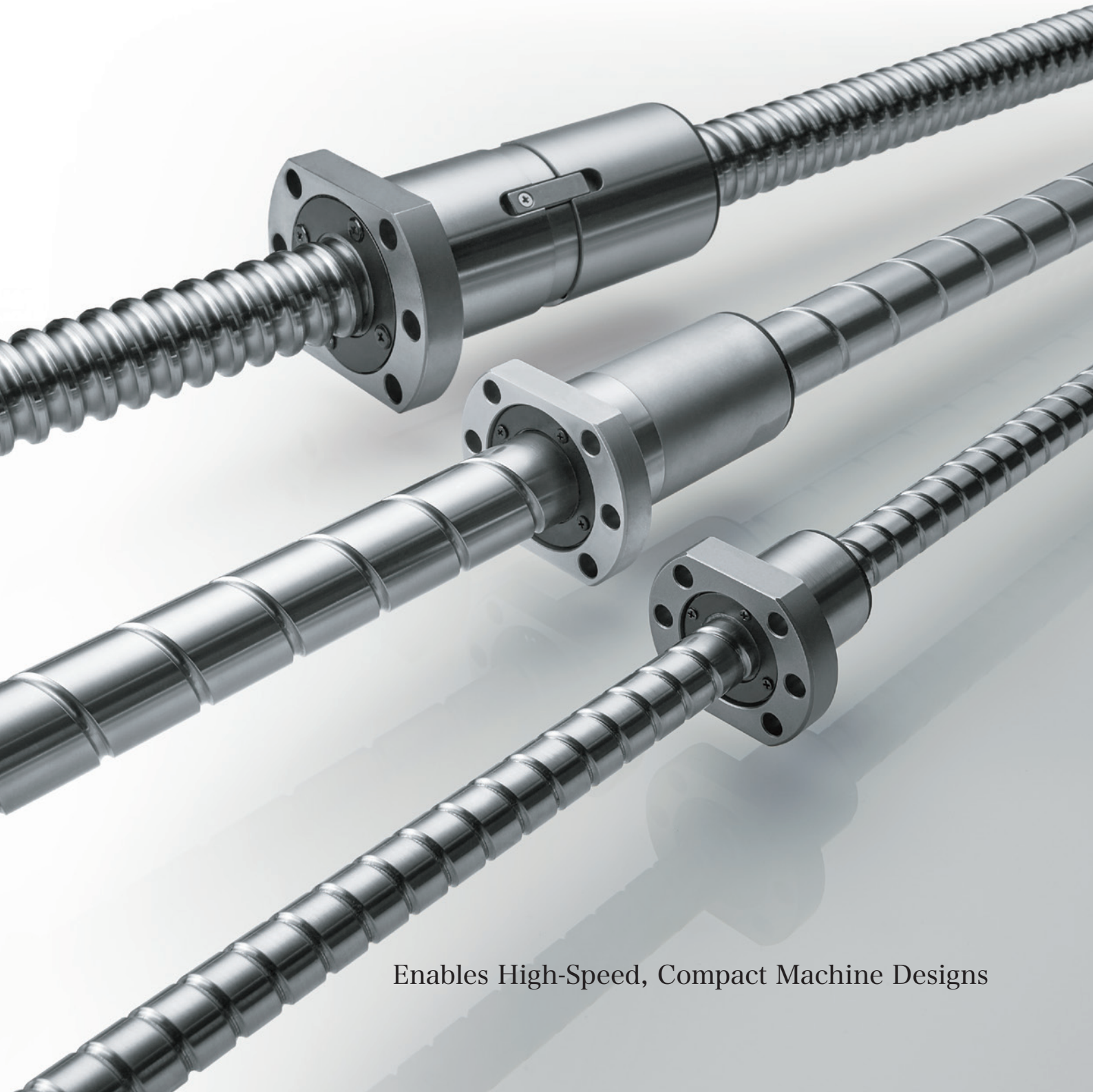

Enables High-Speed, Compact Machine Designs

SDA-V

SDA-V/SDAN-V

■ High speed

Picks up balls in the tangential direction and achieves a maximum rotational speed of $5,000 \text{ min}^{-1}$ (DN value: 160,000).

Torque remains stable even during long periods of high-speed operation.

Conventional precision ball screw
(Caged Ball type)

Maximum DN value
130,000

SDA-V/SDAN-V
(Caged Ball type)

Maximum DN value
160,000

■ Conforms to DIN standards

The outer diameter is up to 30% more compact than previous THK products.

Enables compact machine designs.

Nut dimensions conform to ISO standards (ISO 3408).

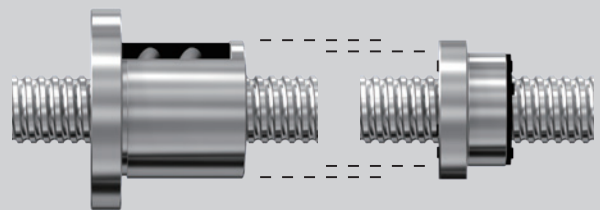

Conventional precision ball screw

SDA-V

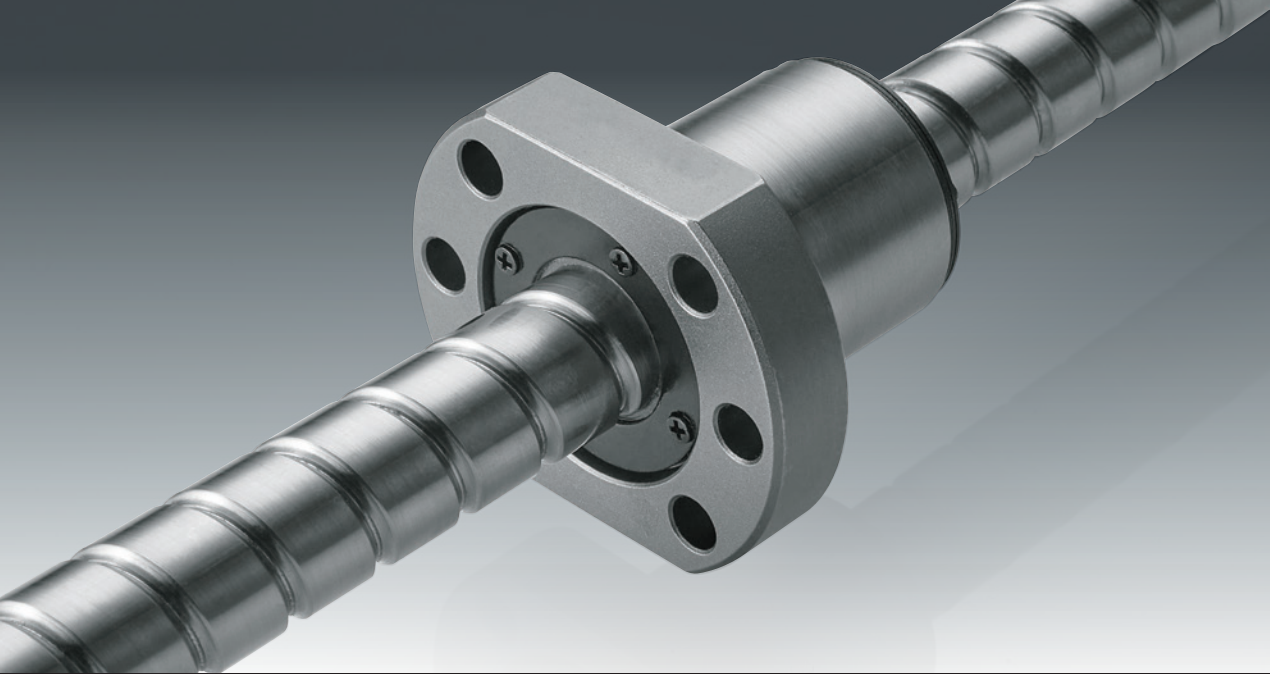

Enables High-Speed, Compact Machine Designs

Picks up balls in the tangential direction

Newly developed circulation components enable an ideal ball circulation structure.

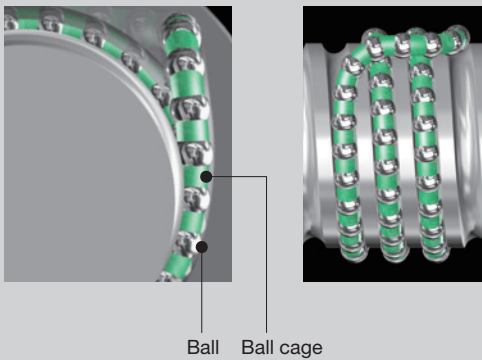

SDA-V/SDAN-V lineup

A diverse product lineup to meet your varied needs. Full-ball types are also available.

●: SDA-V
■: SDAN-V

Shaft diameter	Lead	4	5	6	10	12	16	20	25	30	32	36	40	50
φ10		●	●		●									
φ12			●		●			●		●				
φ14			●		●									
φ15			●		●			●		●				
φ16			●		●		●							
φ20		●	●		●			●		●			●	
φ25			●		●			●	●	●				●
φ28				●										
φ31					■	■	■	■	■			●		
φ32			●		■									
φ36					■	■	■	■	■				●	
φ38					■	■	■	■	■	●	●			●
φ45					■	■	■	■	■	●	●			●
φ50					■	■	■	■	■	●	●			●

●: Additional models

*The above chart is the lineup as of July 2020.

SDAN-V

SDA-V

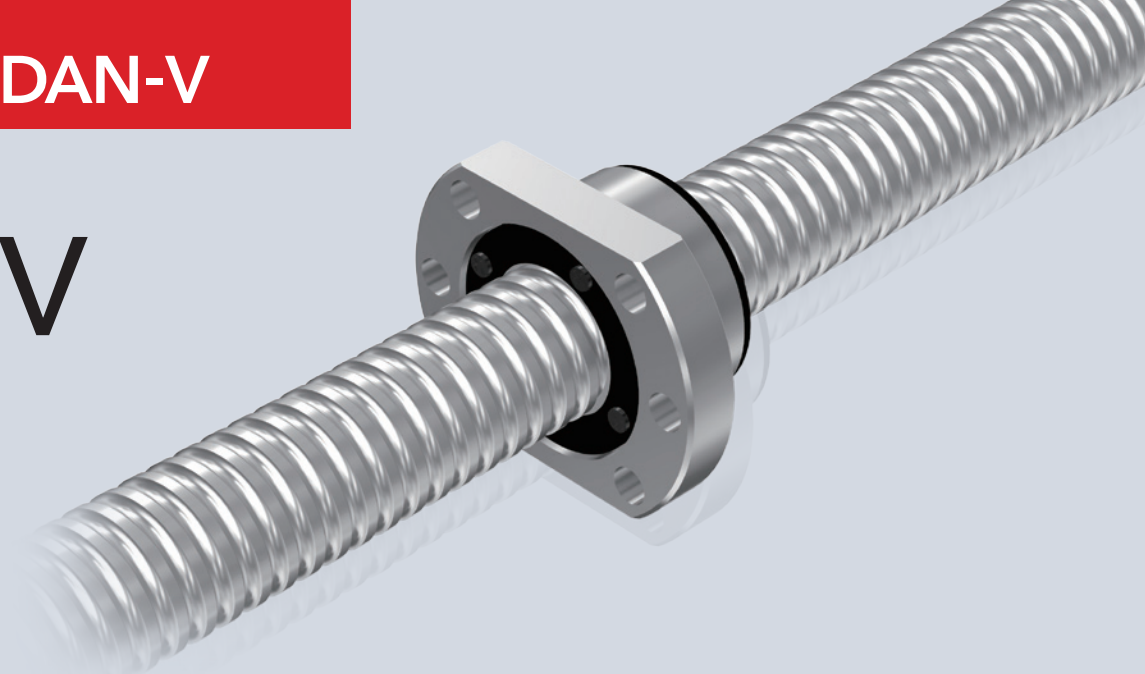

Can be used for a wide range of applications, from small electronic component machinery to large general industrial equipment.

- 62 products are available with a combination of shaft diameters from $\phi 10$ to $\phi 50$ and leads from 4 mm to 50 mm.
- Clearance can be selected, including an axial clearance of 0 or less.

SDA-V Lineup

Shaft diameter \ Lead	4	5	6	10	12	16	20	25	30	32	36	40	50
$\phi 10$	●	●		●									
$\phi 12$		●		●			●		●				
$\phi 14$		●		●					●				
$\phi 15$		●		●			●		●				
$\phi 16$		●		●		●							
$\phi 20$	●	●		●			●		●			●	
$\phi 25$		●		●			●	●	●				●
$\phi 28$			●										
$\phi 31$				●	●	●	●			●			
$\phi 32$		●		●									
$\phi 36$				●	●	●	●				●		
$\phi 38$				●	●	●	●	●	●			●	
$\phi 45$				●	●	●	●	●	●			●	
$\phi 50$				●	●	●	●	●	●			●	●

●: Additional models as of July 2020. $\phi 10$ and $\phi 12$ are only compatible with Model SDA-VZ (full-ball type).

Full-Ball Type (SDA-VZ)

Full-ball types are also available. To request full-ball types, please contact THK.

Model Number Coding Sample

SDA3610V Z -5 TT G0 +640L C3

Model No. | Full-ball type symbol (No symbol for the Caged Ball type) | Number of turns | Seal symbol (p. 6): TT: Thin film seal, CC: Canvas seal | Axial clearance symbol (p. 5): G0, GT, G1, G2, G3 | Overall screw shaft length (in mm): +640L | Accuracy symbol (p. 5): C3

Axial clearance symbol ($\phi 10, 12$)	G0	GT	G1	G2	G3
Axial clearance symbol (other than $\phi 10, 12$)	G0	GT	—	—	—

SDAN-V

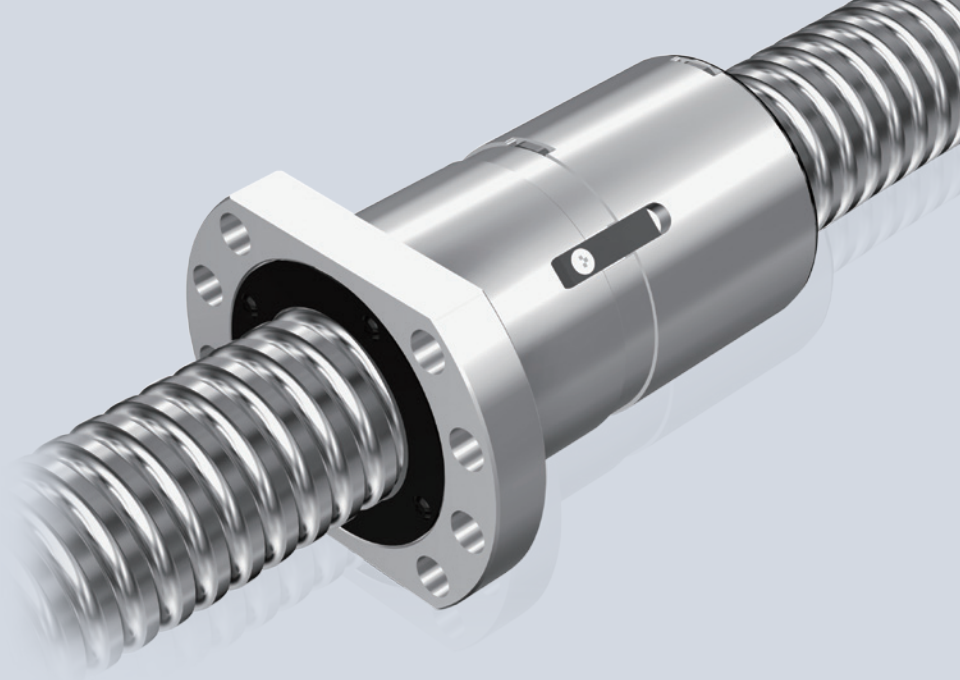

Suitable when it is necessary to minimize displacement from the force of cutting in NC machine tools and precision equipment.

- Designed with higher axial rigidity than the SDA-V.
- A double nut is used to achieve axial clearance of 0 or less.

SDAN-V Lineup

Shaft diameter \ Lead	10	12	16	20
φ31	■	■	■	■
φ36	■	■	■	■
φ38	■	■	■	■
φ45	■	■	■	■
φ50	■	■	■	■

Full-Ball Type (SDAN-VX)

Full-ball types are also available. To request full-ball types, please contact THK.

Model Number Coding Sample

Select an option
Fixed symbol

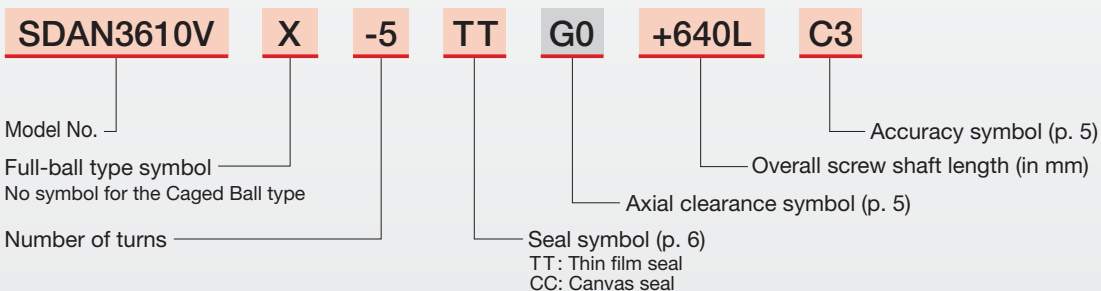

Lead Angle Accuracy and Axial Clearance

Lead Angle Accuracy

Complies with conventional JIS (Japanese Industrial Standards) as well as ISO (international standards) and DIN (German industry standards).

Axial Clearance

The table on the right shows the axial clearance of the precision ball screw.

G0 and GT clearance are standard for the SDA-V.

*For $\phi 10$ and $\phi 12$ only, any axial clearance from G0 to G3 may be selected.

SDAN-V is only available with G0 clearance.

Accuracy Standards Correspondence Table

Accuracy standards	Lead angle accuracy (permissible value)						
	JIS	C0	C1	C2*	C3	C5	C7*
ISO (DIN)	—	—	Cp1	—	Cp3	Cp5	—

*THK standard lead angle accuracy

Clearance symbol	Unit: mm				
	G0	GT	G1	G2	G3
Axial clearance	0 or less	0 to 0.005	0 to 0.01	0 to 0.02	0 to 0.05

*For SDA-V $\phi 12$, any clearance may be selected.

Static Safety Factor

Basic Static Load Rating C_{0a}

The basic static load rating (C_{0a}) generally equals the permissible axial load of a ball screw. In certain conditions, it is necessary to take static safety factors into account with regard to the calculated load. For instance, when the ball screw is stationary or in motion, an unexpected external force may be applied due to inertia caused by an impact or starting and stopping.

Static Safety Factor f_s

$$F_{a_{max}} = \frac{C_{0a}}{f_s}$$

f_s : Static safety factor
 C_{0a} : Basic static load rating* (kN)
 $F_{a_{max}}$: Permissible axial load (kN)

Static Safety Factor (f_s)

Machine	Load conditions	Lower limit of f_s
General industrial machinery	Without vibration or impacts	1.0 to 3.5
	With vibration or impacts	2.0 to 5.0
Machine tools	Without vibration or impacts	1.0 to 4.0
	With vibration or impacts	2.5 to 7.0

*The basic static load rating (C_{0a}) is a static load with a constant direction and magnitude whereby the sum of the permanent deformation of a ball and that of a rolling groove on a contact area under the maximum stress is 0.0001 times that of the ball diameter. With the ball screw, it is defined as the axial load. (Specific values of each ball screw model are indicated in the specification tables for the corresponding model.)

Nominal Life and Service Life in Hours

Basic dynamic load rating C_a

The basic dynamic load rating (C_a) is used in calculations of service life for when the ball screw is under an axial load. The basic dynamic load rating (C_a) indicates the load for which the nominal life L equals 10^6 (rev) when a group of identical ball screws independently operate under that load and it is applied with a constant direction and size. (The basic dynamic load ratings (C_a) for each model number are indicated in the specification tables.)

Nominal Life L_{10m} (total rotations)

A ball screw's service life is obtained from the following equation using the basic dynamic load rating and applied axial load.

$$L_{10m} = \left(\frac{C_a}{f_w \cdot F_a} \right)^3 \times 10^6$$

L : Modified nominal life (total rotations) (rev)
 C_a : Basic dynamic load rating* (kN)
 F_a : Applied axial load (kN)
 f_w : Load factor

Load Factor (f_w)

Vibration/impacts	Speed (V)	f_w
Minute	Under minute speeds $V \leq 0.25$ m/s	1.0 to 1.2
Low	Under low speeds 0.25 m/s < $V \leq 1.0$ m/s	1.2 to 1.5
Medium	Under medium speeds 1.0 m/s < $V \leq 2.0$ m/s	1.5 to 2.0
High	Under high speeds 2.0 m/s < V	2.0 to 3.5

*The nominal life is obtained by calculating the load on the premise that the product is set up in ideal mounting conditions with the assurance of good lubrication. The service life can be affected by the precision of the mounting materials used and any distortion.

Service Life in Hours L_h

Once the nominal life (L_{10m}) has been obtained, the service life in hours (L_h) can be calculated using the following formula if the stroke length and the number of cycles are constant.

$$L_h = \frac{L_{10m} \times Ph}{2 \times l_s \times n \times 60}$$

L_h : Service life in hours (h)
 l_s : Stroke length (mm)
 n : Number of cycles per minute (min^{-1})
 Ph : Lead (mm)

Contamination Protection

If foreign materials enter the ball screw, they may lead to abnormal wear and ball jamming, which could shorten the life of the product. Therefore, it is necessary to prevent foreign material from entering the product. If it is likely that foreign materials will get inside, it is important to select an effective contamination protection device suited to the conditions in which it will be used.

■ Thin Film Seal (TT)

Thin film seals protect against foreign impurities and lubricant discharge through direct contact. They have low sliding resistance and generate little heat.

■ Canvas Seal (CC)

Canvas seals prevent foreign material from entering the nut through elastic contact with the outer diameter of the ball screw shaft and the groove. In addition to exceptional performance at preventing contamination and retaining grease, they are made from resin with high slidability and therefore generate little heat. They are used when higher levels of contamination protection are needed.

*Canvas seals are only compatible with $\phi 14$ to $\phi 50$.

*When canvas seals are applied, the overall nut length may become longer.

*For dimensions after applying dust-proofing seals, see p. 17.

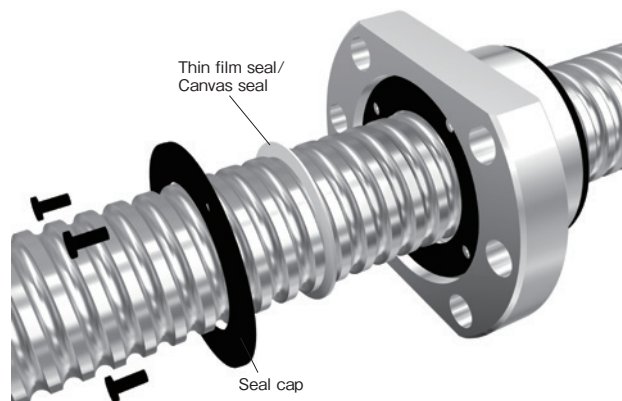

Standard Grease

THK Original Grease AFJ

AFJ grease uses refined mineral oil as its base and has a urea-based consistency enhancer and other special additives that give it excellent lubrication properties at a wide range of speeds from low to high.

*The $\phi 10$ is filled with lithium-based grease No.2 (Multemp PS-2 grease) as standard.

*Non-standard greases are also available. Please contact THK.

Representative physical properties

Item	Representative physical property	Testing method
Consistency enhancer	Urea-based	
Base oil	Refined mineral oil	
Base oil kinematic viscosity: mm ² /s (40°C)	20	JIS K 2220 23
Worked penetration (25°C, 60 W)	325	JIS K 2220 7
Mixing stability (100,000 W)	360	JIS K 2220 15
Dropping point: °C	185	JIS K 2220 8
Evaporation volume: mass% (99°C, 22 h)	0.6	JIS K 2220 10
Oil separation rate: mass% (100°C, 24 h)	7.0	JIS K 2220 11
Copper plate corrosion (B method, 100°C, 24 h)	Passed	JIS K 2220 9
Low-temperature torque mN·m (-20°C)	Starting	38
	Rotational	13
4-ball testing (welding load): N	3089	ASTM D2596
Operating temperature range: °C	-20 to 120	
Color	Yellowish brown	

SDA-V/SDAN-V

Specification Table

SDA-V/SDA-VZ

DN value	SDA-V (Caged Ball)	160000
	SDA-VZ (Full-Ball)	100000

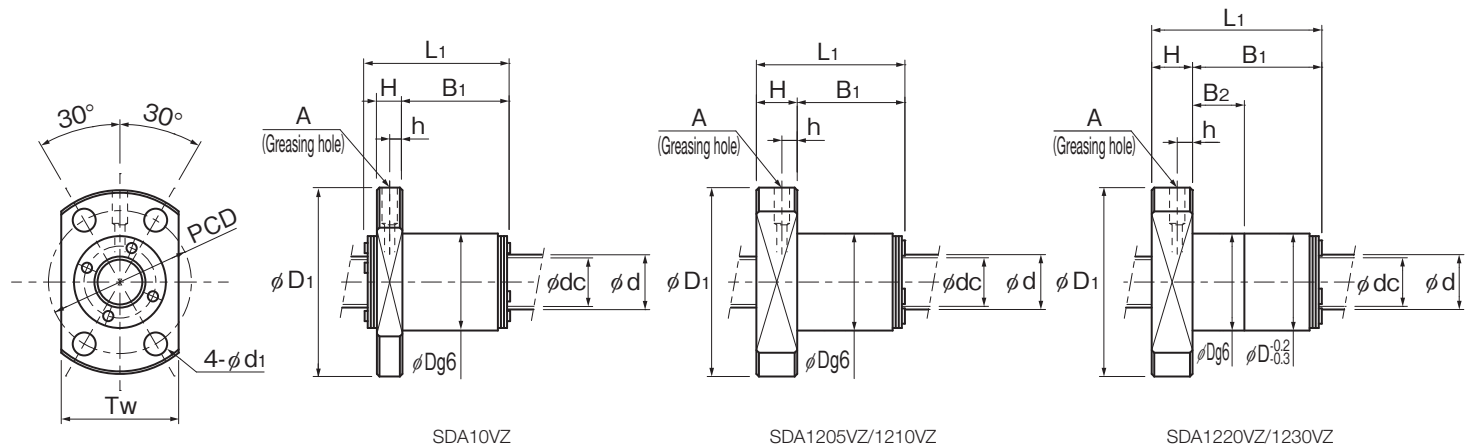

Model No.	Screw shaft outer diameter	Lead	Ball center-to-center diameter	Thread minor diameter	No. of loaded circuits	Basic load rating				Rigidity	
						SDA-V (Caged Ball)		SDA-VZ (Full-Ball)		SDA-V (Caged Ball)	SDA-VZ (Full-Ball)
						Ca (kN)	C _{0a} (kN)	Ca (kN)	C _{0a} (kN)	K (N/μm)	K (N/μm)
* SDA 1004VZ-4	10	4	10.4	8.77	1×4	-	-	3.54	5.42	-	143
* SDA 1005VZ-4	10	5	10.4	8.77	1×4	-	-	3.53	5.44	-	143
* SDA 1010VZ-3	10	10	10.4	8.77	1×3	-	-	2.63	3.86	-	108
* SDA 1205VZ-3	12	5	12.5	10.1	1×3	-	-	4.99	7.02	-	128
* SDA 1210VZ-2	12	10	12.5	10.1	1×2	-	-	3.31	4.25	-	83
* SDA 1220VZ-2	12	20	12.5	10.1	1×2	-	-	3.13	4.63	-	87
* SDA 1230VZ-2	12	30	12.5	10.1	1×2	-	-	2.92	4.14	-	91
SDA 1405V-4	14	5	14.5	12.1	1×4	7.4	10.1	7.1	11.3	178	196
SDA 1505V-3	15	5	15.5	13.1	1×3	5.9	7.9	5.6	8.8	140	153
SDA 1510V-3	15	10	15.5	13.1	1×3	5.8	7.6	5.5	8.4	141	154
SDA 1520V-4	15	20	15.5	13.1	2×2	6.8	10.1	6.5	11.2	181	198
SDA 1530V-4	15	30	15.5	13.1	2×2	6.5	8.8	6.2	9.7	188	205
SDA 1605V-3	16	5	16.5	14.1	1×3	6	8.4	5.8	9.4	147	162
SDA 1610V-3	16	10	16.5	14.1	1×3	6	8.1	5.7	9	148	163
SDA 1616V-3	16	16	16.5	14.1	1×3	5.9	8.4	5.6	9.2	151	165

Note) Models marked with an asterisk (*) in the specification table are only compatible with Model SDA-VZ (full-ball type).

Model Number Coding

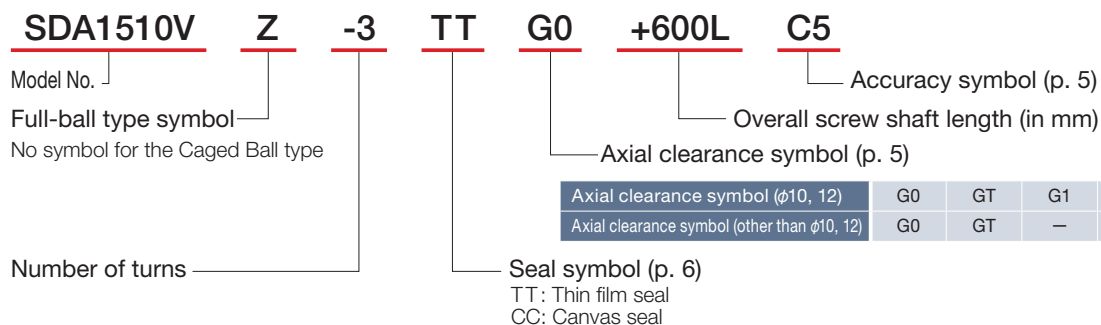

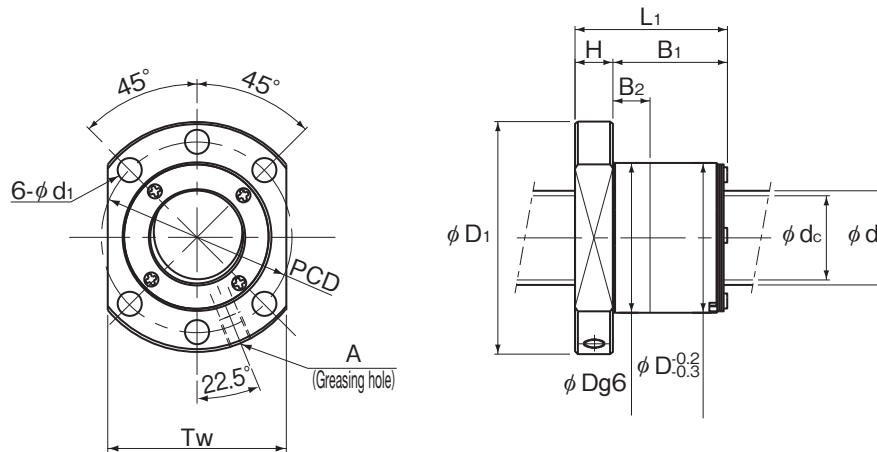

SDA14V to 16V

Unit: mm

	Nut dimensions										Screw shaft inertial moment/mm (kg·m ² /mm)	Nut mass (kg)	Shaft mass (kg/m)	Permissible rotational speed	
	Outer diameter D	Flange diameter D ₁	Total length L ₁	H	B ₁	B ₂	PCD	d ₁	T _w	Greasing hole A				SDA-V (Caged Ball) (min ⁻¹)	SDA-VZ (Full-Ball) (min ⁻¹)
	19	36	24	6	16	-	28	4.5	23	phi 3	7.71 × 10 ⁻⁹	0.047	0.577	-	5000
	19	36	28	6	20	-	28	4.5	23	phi 3	7.71 × 10 ⁻⁹	0.052	0.585	-	5000
	19	36	37	6	29	-	28	4.5	23	phi 3	7.71 × 10 ⁻⁹	0.066	0.600	-	5000
	24	40	25	8	17	-	32	4.5	26	phi 3	1.60 × 10 ⁻⁸	0.073	0.796	-	5000
	24	40	29	8	21	-	32	4.5	26	phi 3	1.60 × 10 ⁻⁸	0.082	0.841	-	5000
	24	40	47	8	39	20	32	4.5	26	phi 3	1.60 × 10 ⁻⁸	0.126	0.863	-	5000
	24	40	65	8	57	20	32	4.5	26	phi 3	1.60 × 10 ⁻⁸	0.172	0.869	-	5000
	26	48	30	10	20	10	38	5.5	40	M6	2.96 × 10 ⁻⁸	0.14	1.10	5000	5000
	28	48	25	10	15	12.5	38	5.5	40	M6	3.90 × 10 ⁻⁸	0.13	1.27	5000	5000
	28	48	38	10	28	25.5	38	5.5	40	M6	3.90 × 10 ⁻⁸	0.17	1.33	5000	5000
	28	48	46	10	36	20	38	5.5	40	M6	3.90 × 10 ⁻⁸	0.19	1.33	5000	5000
	28	48	65	10	55	20	38	5.5	40	M6	3.90 × 10 ⁻⁸	0.25	1.34	5000	5000
	28	48	25	10	15	12.5	38	5.5	40	M6	5.05 × 10 ⁻⁸	0.13	1.46	5000	5000
	28	48	39	10	29	26.5	38	5.5	40	M6	5.05 × 10 ⁻⁸	0.16	1.52	5000	5000
	28	48	56	10	46	20	38	5.5	40	M6	5.05 × 10 ⁻⁸	0.21	1.54	5000	5000

Note) The groove on the screw shaft cannot be cut on both ends. Contact THK if you require such a design.

The rigidity values (K) in the table represent spring constants, each obtained from the load and the elastic deformation under an axial load equal to 30% of the basic axial dynamic load rating (Ca).

These values do not include the rigidity of the components related to mounting the ball screw nut. Therefore, it is generally appropriate to regard roughly 80% of the rigidity value (K) in the table as the actual value.

If the axial load (Fa) is not 0.3 Ca, the rigidity value (K_N) is obtained from the following equation.

$$K_N = K \left(\frac{Fa}{0.3Ca} \right)^{\frac{1}{3}}$$

K: Rigidity value in the specification table

Specification Table

SDA-V/SDA-VZ

DN value	SDA-V (Caged Ball)	160000
	SDA-VZ (Full-Ball)	100000

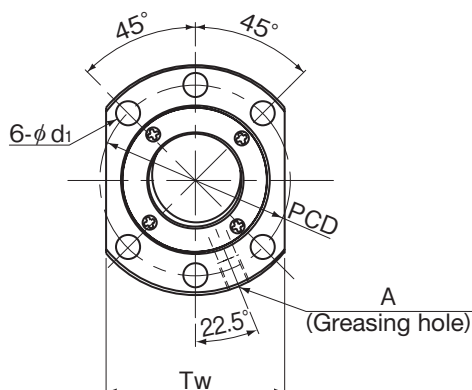

Model No.	Screw shaft outer diameter d	Lead Ph	Ball center-to-center diameter dp	Thread minor diameter dc	No. of loaded circuits Rows × turns	Basic load rating				Rigidity	
						SDA-V (Caged Ball)		SDA-VZ (Full-Ball)		SDA-V (Caged Ball)	SDA-VZ (Full-Ball)
						Ca (kN)	C _{0a} (kN)	Ca (kN)	C _{0a} (kN)	K (N/μm)	K (N/μm)
SDA 2004V-4	20	4	20.5	18.1	1×4	8.8	14.7	8.3	16.2	239	260
SDA 2005V-3	20	5	20.75	17.1	1×3	11.7	17.7	11.1	18.9	200	213
SDA 2010V-3	20	10	20.75	17.1	1×3	11.6	17.7	11	19	200	213
SDA 2020V-3	20	20	20.75	17.1	1×3	11.4	17.2	10.8	18.5	203	217
SDA 2030V-2	20	30	20.75	17.1	1×2	7.4	11.5	7	12.3	135	143
SDA 2040V-2	20	40	20.75	17.1	1×2	7.1	9.7	6.8	10.4	137	147
SDA 2505V-3	25	5	25.75	22.1	1×3	12.9	22	12.3	23.7	237	254
SDA 2510V-3	25	10	25.75	22.1	1×3	12.8	22	12.2	23.8	237	254
SDA 2520V-3	25	20	25.75	22.1	1×3	12.7	21.3	12.1	22.9	241	257
SDA 2525V-3	25	25	25.75	22.1	1×3	12.5	21.6	11.9	23.3	243	259
SDA 2530V-2	25	30	25.75	22.1	1×2	8.3	13.9	7.9	14.9	158	168
SDA 2550V-2	25	50	25.75	22.1	1×2	7.8	12.1	7.5	13.1	163	176

Model Number Coding

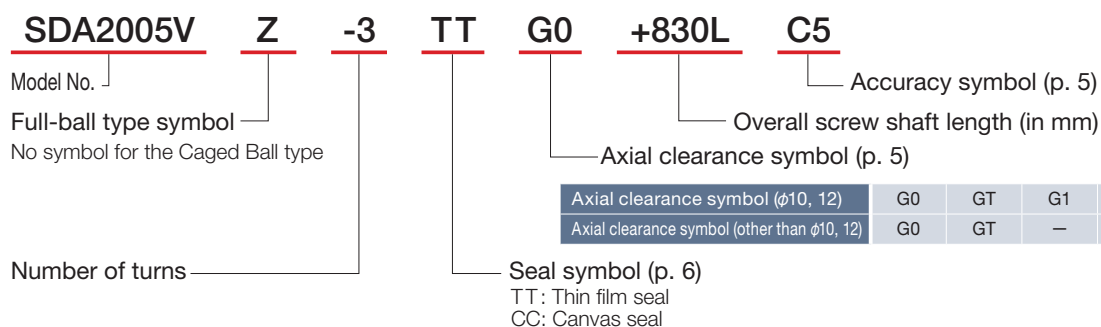

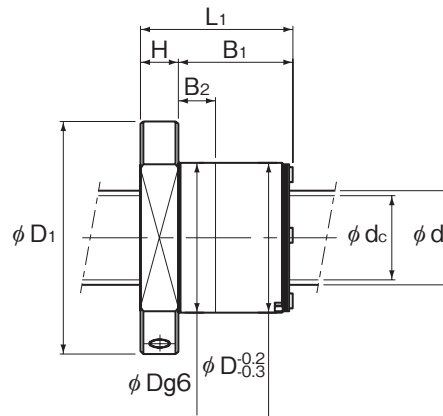

Unit: mm

	Nut dimensions										Screw shaft inertial moment/mm (kg·m ² /mm)	Nut mass (kg)	Shaft mass (kg/m)	Permissible rotational speed	
	Outer diameter	Flange diameter	Total length	H	B ₁	B ₂	PCD	d ₁	T _w	Greasing hole				SDA-V (Caged Ball)	SDA-VZ (Full-Ball)
	D	D ₁	L ₁												
	32	58	27	10	17	13.8	47	6.6	44	M6	1.23×10 ⁻⁷	0.17	2.27	5000	4878
	36	58	27	10	17	13.5	47	6.6	44	M6	1.23×10 ⁻⁷	0.18	2.21	5000	4819
	36	58	40	10	30	27	47	6.6	44	M6	1.23×10 ⁻⁷	0.25	2.34	5000	4819
	36	58	67	10	57	20	47	6.6	44	M6	1.23×10 ⁻⁷	0.39	2.4	5000	4819
	36	58	66	10	56	20	47	6.6	44	M6	1.23×10 ⁻⁷	0.38	2.42	5000	4819
	36	58	84	10	74	20	47	6.6	44	M6	1.23×10 ⁻⁷	0.47	2.43	5000	4819
	40	62	27	10	17	13.5	51	6.6	48	M6	3.01×10 ⁻⁷	0.2	3.53	5000	3883
	40	62	40	10	30	27	51	6.6	48	M6	3.01×10 ⁻⁷	0.28	3.7	5000	3883
	40	62	67	10	57	20	51	6.6	48	M6	3.01×10 ⁻⁷	0.42	3.78	5000	3883
	40	62	82	10	72	20	51	6.6	48	M6	3.01×10 ⁻⁷	0.5	3.79	5000	3883
	40	62	66	10	56	20	51	6.6	48	M6	3.01×10 ⁻⁷	0.41	3.8	5000	3883
	40	62	102	10	92	20	51	6.6	48	M6	3.01×10 ⁻⁷	0.61	3.83	5000	3883

Note) The groove on the screw shaft cannot be cut on both ends. Contact THK if you require such a design.

The rigidity values (K) in the table represent spring constants, each obtained from the load and the elastic deformation under an axial load equal to 30% of the basic axial dynamic load rating (Ca).

These values do not include the rigidity of the components related to mounting the ball screw nut. Therefore, it is generally appropriate to regard roughly 80% of the rigidity value (K) in the table as the actual value.

If the axial load (Fa) is not 0.3 Ca, the rigidity value (K_N) is obtained from the following equation.

$$K_N = K \left(\frac{Fa}{0.3Ca} \right)^{\frac{1}{3}}$$

K: Rigidity value in the specification table

Specification Table

SDA-V/SDA-VZ

DN value	SDA-V (Caged Ball)	160000
	SDA-VZ (Full-Ball)	130000

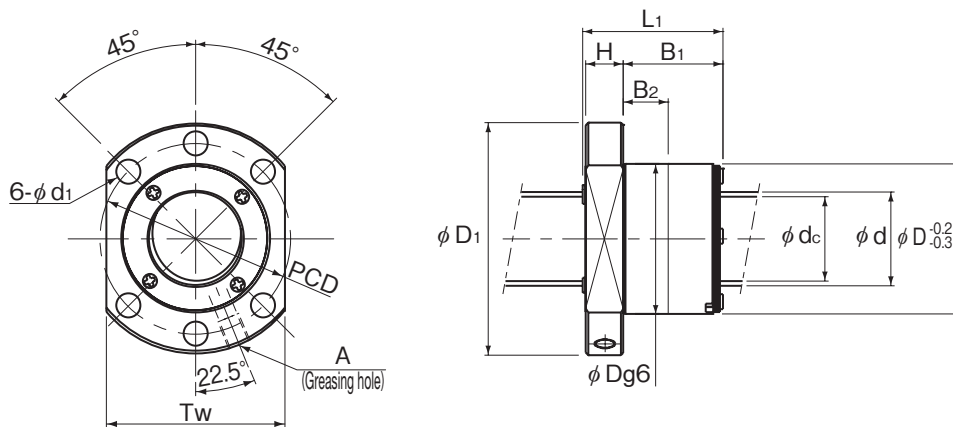

SDA28V to 31V

Model No.	Screw shaft outer diameter	Lead	Ball center-to-center diameter	Thread minor diameter	No. of loaded circuits	Basic load rating				Rigidity	
						SDA-V (Caged Ball)		SDA-VZ (Full-Ball)		SDA-V (Caged Ball)	SDA-VZ (Full-Ball)
						Ca (kN)	C _{0a} (kN)	Ca (kN)	C _{0a} (kN)	K (N/μm)	K (N/μm)
SDA 2806V-5	28	6	29	24.9	1×5	29.6	54.5	28.2	57.7	462	487
SDA 3110V-5	31	10	32	25.4	1×5	57.1	94.7	54.4	99.7	529	554
SDA 3112V-5	31	12	32	25.4	1×5	57	94.7	54.3	99.9	529	555
SDA 3116V-5	31	16	32	25.4	1×5	56.8	96	54.1	100.5	534	556
SDA 3120V-5	31	20	32	25.4	1×5	56.6	90.3	53.9	95.1	533	558
SDA 3132V-2	31	32	32	25.4	1×2	23.2	33.8	22.1	35.4	206	214
SDA 3205V-4	32	5	32.75	29.1	1×4	18.8	38.5	17.9	41.7	388	416
SDA 3210V-5	32	10	33	28.9	1×5	31.3	62.9	29.8	66.3	517	541
SDA 3610V-5	36	10	37	30.4	1×5	61.7	110.6	58.8	116.4	598	626
SDA 3612V-5	36	12	37	30.4	1×5	61.7	110.6	58.7	116.6	598	627
SDA 3616V-5	36	16	37	30.4	1×5	61.5	111.9	58.6	117.1	603	628
SDA 3620V-5	36	20	37	30.4	1×5	61.3	105.2	58.4	110.6	602	629
SDA 3636V-2	36	36	37	30.4	1×2	25.1	39.3	23.9	41.3	232	242
SDA 3810V-5	38	10	39	32.4	1×5	63.4	117.7	60.4	123.1	629	654
SDA 3812V-5	38	12	39	32.4	1×5	63.4	117.7	60.3	123.3	628	655
SDA 3816V-5	38	16	39	32.4	1×5	63.2	117.7	60.2	123.7	627	656
SDA 3820V-5	38	20	39	32.4	1×5	63	111.9	60	116.9	632	657
SDA 3825V-4	38	25	39	32.4	1×4	51.1	87.8	48.6	92.7	500	525
SDA 3830V-3	38	30	39	32.4	1×3	38.7	64.9	36.9	68.2	373	390
SDA 3840V-2	38	40	39	32.4	1×2	25.7	42	24.4	43.9	244	253

Model Number Coding

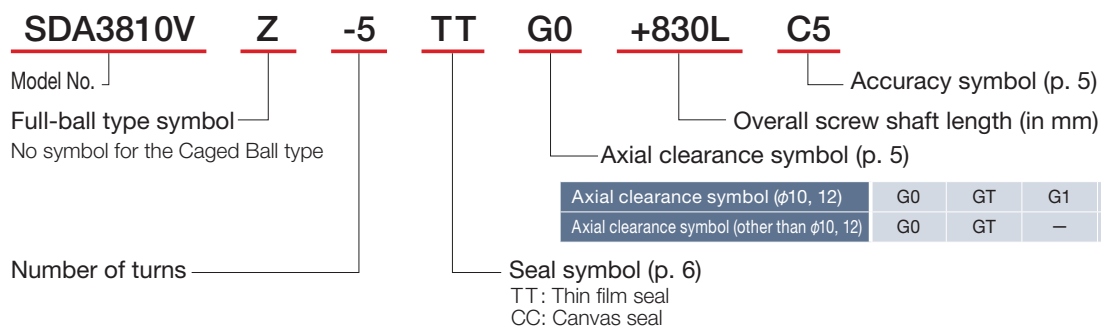

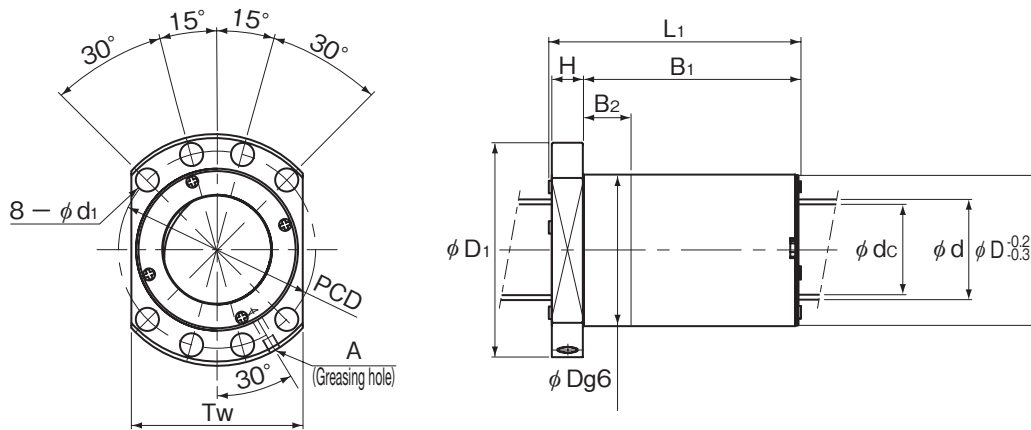

SDA36V to 38V

Unit: mm

	Nut dimensions										Screw shaft inertial moment/mm (kg·m ² /mm)	Nut mass (kg)	Shaft mass (kg/m)	Permissible rotational speed	
	Outer diameter D	Flange diameter D ₁	Total length L ₁	H	B ₁	B ₂	PCD	d ₁	T _w	Greasing hole A				SDA-V (Caged Ball) (min ⁻¹)	SDA-VZ (Full-Ball) (min ⁻¹)
	46	80	42	12	30	10	65	9	62	M6	4.74×10 ⁻⁷	0.49	4.37	5000	4482
	56	86	65	14	50	20	71	9	65	M6	7.07×10 ⁻⁷	0.96	5.02	5000	4063
	56	86	74	14	59	20	71	9	65	M6	7.07×10 ⁻⁷	1.08	5.17	5000	4063
	56	86	93	14	78	20	71	9	65	M6	7.07×10 ⁻⁷	1.31	5.36	5000	4063
	56	86	112	14	97	20	71	9	65	M6	7.07×10 ⁻⁷	1.54	5.47	5000	4063
	56	86	73	14	58	20	71	9	65	M6	7.07×10 ⁻⁷	1.04	5.63	5000	4063
	50	80	32	12	20	16.5	65	9	62	M6	8.08×10 ⁻³	0.41	5.89	4885	3969
	50	80	61	12	49	10	65	9	62	M6	8.08×10 ⁻⁷	0.64	6.00	4848	3969
	61	91	65	14	50	20	76	9	68	M8×1	1.29×10 ⁻⁶	1.06	6.93	4324	3514
	61	91	74	14	59	20	76	9	68	M8×1	1.29×10 ⁻⁶	1.19	7.11	4324	3514
	61	91	93	14	78	20	76	9	68	M8×1	1.29×10 ⁻⁶	1.45	7.34	4324	3514
	61	91	112	14	97	20	76	9	68	M8×1	1.29×10 ⁻⁶	1.7	7.47	4324	3514
	61	91	81	14	66	20	76	9	68	M8×1	1.29×10 ⁻⁶	1.24	7.69	4324	3514
	63	93	65	14	50	20	78	9	70	M8×1	1.60×10 ⁻⁶	1.1	7.79	4103	3333
	63	93	74	14	59	20	78	9	70	M8×1	1.60×10 ⁻⁶	1.23	7.97	4103	3333
	63	93	93	14	78	20	78	9	70	M8×1	1.60×10 ⁻⁶	1.5	8.21	4103	3333
	63	93	112	14	97	20	78	9	70	M8×1	1.60×10 ⁻⁶	1.77	8.35	4103	3333
	63	93	111	14	96	20	78	9	70	M8×1	1.60×10 ⁻⁶	1.73	8.45	4103	3333
	63	93	100	14	85	20	78	9	70	M8×1	1.60×10 ⁻⁶	1.56	8.53	4103	3333
	63	93	87	14	72	20	78	9	70	M8×1	1.60×10 ⁻⁶	1.38	8.62	4103	3333

Note) The groove on the screw shaft cannot be cut on both ends. Contact THK if you require such a design.

The rigidity values (K) in the table represent spring constants, each obtained from the load and the elastic deformation under an axial load equal to 30% of the basic axial dynamic load rating (Ca).

These values do not include the rigidity of the components related to mounting the ball screw nut. Therefore, it is generally appropriate to regard roughly 80% of the rigidity value (K) in the table as the actual value.

If the axial load (Fa) is not 0.3 Ca, the rigidity value (K_N) is obtained from the following equation.

$$K_N = K \left(\frac{Fa}{0.3Ca} \right)^{\frac{1}{3}}$$

K: Rigidity value in the specification table

Specification Table

SDA-V/SDA-VZ

DN value	SDA-V (Caged Ball)	160000
	SDA-VZ (Full-Ball)	130000

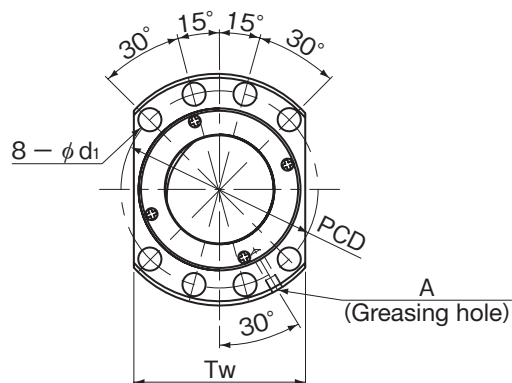

Model No.	Screw shaft outer diameter d	Lead Ph	Ball center-to-center diameter dp	Thread minor diameter dc	No. of loaded circuits Rows x turns	Basic load rating				Rigidity	
						SDA-V (Caged Ball)		SDA-VZ (Full-Ball)		SDA-V (Caged Ball)	SDA-VZ (Full-Ball)
						Ca (kN)	C _{0a} (kN)	Ca (kN)	C _{0a} (kN)	K (N/μm)	K (N/μm)
SDA 4510V-5	45	10	46	39.4	1×5	68.7	139.4	65.4	146.5	717	749
SDA 4512V-5	45	12	46	39.4	1×5	68.6	139.4	65.4	146.7	717	750
SDA 4516V-5	45	16	46	39.4	1×5	68.5	140.7	65.3	147	722	751
SDA 4520V-5	45	20	46	39.4	1×5	68.4	140.7	65.1	147.5	721	752
SDA 4525V-4	45	25	46	39.4	1×4	55.5	104	52.8	109.8	572	600
SDA 4530V-4	45	30	46	39.4	1×4	55.3	105.3	52.6	110.5	577	602
SDA 4540V-3	45	40	46	39.4	1×3	41.7	78.3	39.7	81.9	431	449
SDA 5010V-5	50	10	51	44.4	1×5	72	155.2	68.6	163.2	780	815
SDA 5012V-5	50	12	51	44.4	1×5	72	155.2	68.5	163.3	779	816
SDA 5016V-5	50	16	51	44.4	1×5	71.9	156.6	68.4	163.7	785	816
SDA 5020V-5	50	20	51	44.4	1×5	71.7	156.6	68.3	164.2	784	817
SDA 5025V-4	50	25	51	44.4	1×4	58.2	123.6	55.5	129.8	624	652
SDA 5030V-4	50	30	51	44.4	1×4	58	117.5	55.3	122.6	629	654
SDA 5040V-3	50	40	51	44.4	1×3	43.9	86.5	41.8	90.7	467	487
SDA 5050V-2	50	50	51	44.4	1×2	29.2	55.5	27.8	58	303	316

Model Number Coding

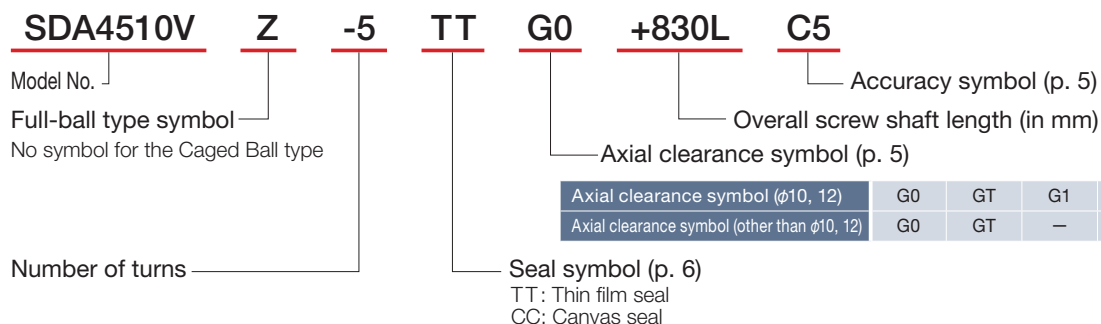

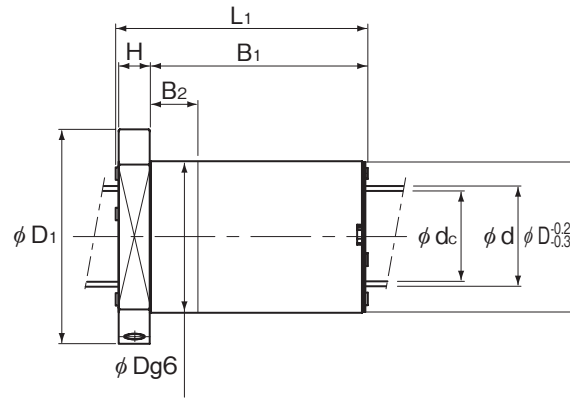

Unit: mm

	Nut dimensions										Screw shaft inertial moment/mm (kg·m ² /mm)	Nut mass (kg)	Shaft mass (kg/m)	Permissible rotational speed	
	Outer diameter	Flange diameter	Total length	H	B ₁	B ₂	PCD	d ₁	T _w	Greasing hole				SDA-V (Caged Ball)	SDA-VZ (Full-Ball)
	D	D ₁	L ₁												
	70	105	65	16	48	20	88	11	80	M8×1	3.16×10 ⁻⁶	1.35	11.16	3478	2826
	70	105	74	16	57	20	88	11	80	M8×1	3.16×10 ⁻⁶	1.5	11.38	3478	2826
	70	105	93	16	76	20	88	11	80	M8×1	3.16×10 ⁻⁶	1.81	11.67	3478	2826
	70	105	112	16	95	20	88	11	80	M8×1	3.16×10 ⁻⁶	2.11	11.84	3478	2826
	70	105	110	16	93	20	88	11	80	M8×1	3.16×10 ⁻⁶	2.04	11.95	3478	2826
	70	105	130	16	113	20	88	11	80	M8×1	3.16×10 ⁻⁶	2.36	12.04	3478	2826
	70	105	129	16	112	20	88	11	80	M8×1	3.16×10 ⁻⁶	2.33	12.16	3478	2826
	75	110	65	16	48	20	93	11	85	M8×1	4.82×10 ⁻⁶	1.46	13.93	3137	2549
	75	110	74	16	57	20	93	11	85	M8×1	4.82×10 ⁻⁶	1.63	14.19	3137	2549
	75	110	93	16	76	20	93	11	85	M8×1	4.82×10 ⁻⁶	1.96	14.5	3137	2549
	75	110	112	16	95	20	93	11	85	M8×1	4.82×10 ⁻⁶	2.29	14.69	3137	2549
	75	110	110	16	93	20	93	11	85	M8×1	4.82×10 ⁻⁶	2.22	14.82	3137	2549
	75	110	130	16	113	20	93	11	85	M8×1	4.82×10 ⁻⁶	2.57	14.92	3137	2549
	75	110	128	16	111	20	93	11	85	M8×1	4.82×10 ⁻⁶	2.52	15.06	3137	2549
	75	110	107	16	90	20	93	11	85	M8×1	4.82×10 ⁻⁶	2.13	15.13	3137	2549

Note) The groove on the screw shaft cannot be cut on both ends. Contact THK if you require such a design.

The rigidity values (K) in the table represent spring constants, each obtained from the load and the elastic deformation under an axial load equal to 30% of the basic axial dynamic load rating (Ca).

These values do not include the rigidity of the components related to mounting the ball screw nut. Therefore, it is generally appropriate to regard roughly 80% of the rigidity value (K) in the table as the actual value.

If the axial load (Fa) is not 0.3 Ca, the rigidity value (K_N) is obtained from the following equation.

$$K_N = K \left(\frac{F_a}{0.3Ca} \right)^{\frac{1}{3}}$$

K: Rigidity value in the specification table

Specification Table

SDAN-V/SDAN-VX

DN value	SDAN-V (Caged Ball)	160000
	SDAN-VX (Full-Ball)	130000

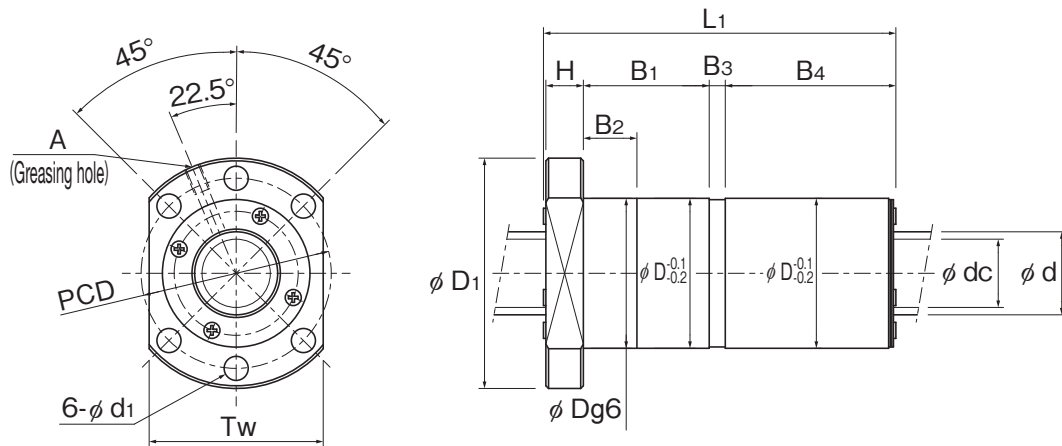

SDAN31V

Model No.	Screw shaft outer diameter	Lead	Ball center-to-center diameter	Thread minor diameter	No. of loaded circuits	Basic load rating				Rigidity	
						SDAN-V (Caged Ball)		SDAN-VX (Full-Ball)		SDAN-V (Caged Ball)	SDAN-VX (Full-Ball)
						Ca (kN)	C _{0a} (kN)	Ca (kN)	C _{0a} (kN)	K (N/μm)	K (N/μm)
SDAN 3110V-5	31	10	32	25.4	1×5	57.1	94.7	54.4	99.7	1059	1108
SDAN 3112V-5	31	12	32	25.4	1×5	57	94.7	54.3	99.9	1058	1109
SDAN 3116V-5	31	16	32	25.4	1×5	56.8	96	54.1	100.5	1068	1112
SDAN 3120V-5	31	20	32	25.4	1×5	56.6	90.3	53.9	95.1	1065	1116
SDAN 3610V-5	36	10	37	30.4	1×5	61.7	110.6	58.8	116.4	1196	1252
SDAN 3612V-5	36	12	37	30.4	1×5	61.7	110.6	58.7	116.6	1195	1253
SDAN 3616V-5	36	16	37	30.4	1×5	61.5	111.9	58.6	117.1	1206	1255
SDAN 3620V-5	36	20	37	30.4	1×5	61.3	105.2	58.4	110.6	1203	1258
SDAN 3810V-5	38	10	39	32.4	1×5	63.4	117.7	60.4	123.1	1257	1308
SDAN 3812V-5	38	12	39	32.4	1×5	63.4	117.7	60.3	123.3	1256	1309
SDAN 3816V-5	38	16	39	32.4	1×5	63.2	117.7	60.2	123.7	1254	1311
SDAN 3820V-5	38	20	39	32.4	1×5	63	111.9	60	116.9	1265	1314
SDAN 4510V-5	45	10	46	39.4	1×5	68.7	139.4	65.4	146.5	1434	1499
SDAN 4512V-5	45	12	46	39.4	1×5	68.6	139.4	65.4	146.7	1433	1500
SDAN 4516V-5	45	16	46	39.4	1×5	68.5	140.7	65.3	147	1444	1501
SDAN 4520V-5	45	20	46	39.4	1×5	68.4	140.7	65.1	147.5	1442	1504
SDAN 5010V-5	50	10	51	44.4	1×5	72	155.2	68.6	163.2	1559	1630
SDAN 5012V-5	50	12	51	44.4	1×5	72	155.2	68.5	163.3	1559	1631
SDAN 5016V-5	50	16	51	44.4	1×5	71.9	156.6	68.4	163.7	1570	1633
SDAN 5020V-5	50	20	51	44.4	1×5	71.7	156.6	68.3	164.2	1568	1635

Model Number Coding

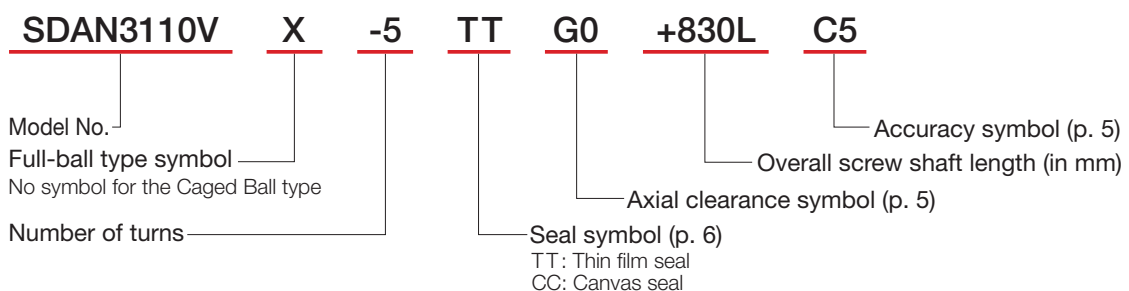

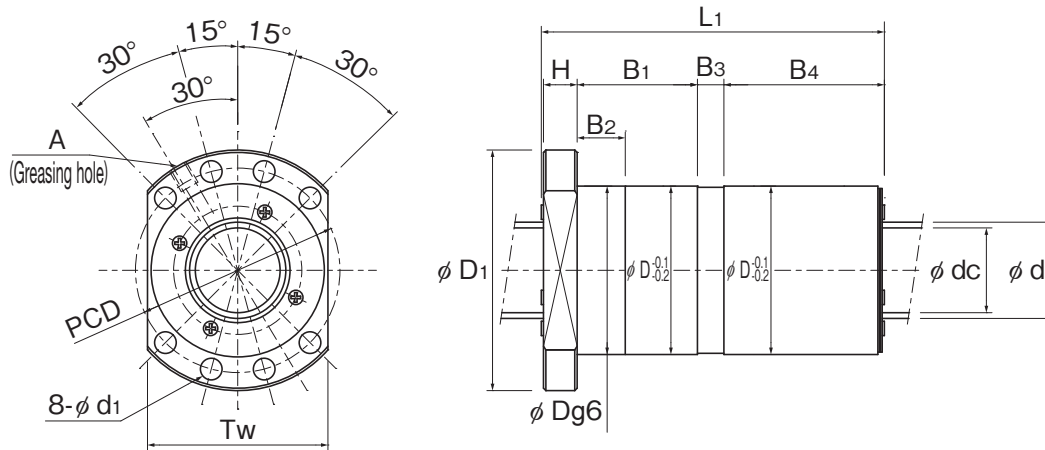

SDAN36V to 50V

Unit: mm

Outer diameter	Flange diameter	Total length	Nut dimensions									Greasing hole	Screw shaft inertial moment/mm	Nut mass	Shaft mass	Permissible rotational speed	
			H	B ₁	B ₂	Shim plate thickness	B ₄	PCD	d ₁	T _w	A					SDAN-V (Caged Ball)	SDAN-VX (Full-Ball)
D	D ₁	L ₁										(kg·m ² /mm)	(kg)	(kg/m)	(min ⁻¹)	(min ⁻¹)	
56	86	135	14	47	20	11	62	71	9	65	M6	7.07×10 ⁻⁷	1.83	5.02	5000	4063	
56	86	158	14	56	20	15.6	72	71	9	65	M6	7.07×10 ⁻⁷	2.1	5.17	5000	4063	
56	86	189	14	75	20	8.9	90	71	9	65	M6	7.07×10 ⁻⁷	2.5	5.36	5000	4063	
56	86	232	14	94	20	14.1	109	71	9	65	M6	7.07×10 ⁻⁷	3.01	5.48	5000	4063	
61	91	135	14	47	20	11	62	76	9	68	M8×1	1.29×10 ⁻⁶	2	6.93	4324	3514	
61	91	158	14	56	20	15.6	72	76	9	68	M8×1	1.29×10 ⁻⁶	2.31	7.11	4324	3514	
61	91	189	14	75	20	8.8	90	76	9	68	M8×1	1.29×10 ⁻⁶	2.77	7.34	4324	3514	
61	91	232	14	94	20	14	109	76	9	68	M8×1	1.29×10 ⁻⁶	3.33	7.47	4324	3514	
63	93	135	14	47	20	11.1	62	78	9	70	M8×1	1.60×10 ⁻⁶	2.08	7.79	4103	3333	
63	93	158	14	56	20	15.7	71	78	9	70	M8×1	1.60×10 ⁻⁶	2.4	7.97	4103	3333	
63	93	189	14	75	20	8.9	90	78	9	70	M8×1	1.60×10 ⁻⁶	2.89	8.21	4103	3333	
63	93	232	14	94	20	14.2	109	78	9	70	M8×1	1.60×10 ⁻⁶	3.44	8.35	4103	3333	
70	105	135	16	45	20	11	62	88	11	80	M8×1	3.16×10 ⁻⁶	2.47	11.16	3478	2826	
70	105	158	16	54	20	15.6	72	88	11	80	M8×1	3.16×10 ⁻⁶	2.84	11.38	3478	2826	
70	105	189	16	73	20	8.8	90	88	11	80	M8×1	3.16×10 ⁻⁶	3.36	11.67	3478	2826	
70	105	232	16	92	20	14	109	88	11	80	M8×1	3.16×10 ⁻⁶	4.03	11.83	3478	2826	
75	110	135	16	45	20	11	62	93	11	85	M8×1	4.82×10 ⁻⁶	2.69	13.93	3137	2549	
75	110	158	16	54	20	15.6	72	93	11	85	M8×1	4.82×10 ⁻⁶	3.08	14.19	3137	2549	
75	110	189	16	73	20	8.8	90	93	11	85	M8×1	4.82×10 ⁻⁶	3.65	14.5	3137	2549	
75	110	232	16	92	20	14	109	93	11	85	M8×1	4.82×10 ⁻⁶	4.39	14.69	3137	2549	

Note) The groove on the screw shaft cannot be cut on both ends. Contact THK if you require such a design.

The rigidity values in the table represent spring constants, each obtained from the load and the elastic deformation when providing a preload equal to 10% of the basic axial dynamic load rating (Ca) and applying an axial load three times greater than the preload.

These values do not include the rigidity of the components related to mounting the ball screw nut. Therefore, it is normally appropriate to regard roughly 80% of the value in the table as the actual value.

If the applied preload (Fa₀) is not 0.1 Ca, the rigidity value (K_N) is obtained from the following equation.

$$K_N = K \left(\frac{F_{a0}}{0.1Ca} \right)^{\frac{1}{3}}$$

K: Rigidity value in the specification table

Dimensions after Applying Dust-Proofing Seals

SDA-V

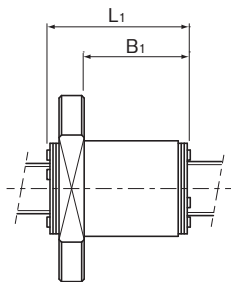

SDA10VZ

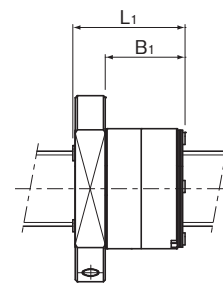

SDA12VZ to 50V

Unit: mm

Model No.	SDA-V_TT (with thin film seal)		SDA-V_CC (with canvas seal)	
	L ₁	B ₁	L ₁	B ₁
SDA 1004VZ-4	24	16	—	—
SDA 1005VZ-4	28	20	—	—
SDA 1010VZ-3	37	29	—	—
SDA 1205VZ-3	24	16	—	—
SDA 1210VZ-2	28	20	—	—
SDA 1220VZ-2	45	37	—	—
SDA 1230VZ-2	64	56	—	—
SDA 1405V-3	30	20	31	21
SDA 1505V-3	25	15	26	16
SDA 1510V-3	38	28	39	29
SDA 1520V-4	46	36	47	37
SDA 1530V-4	65	55	65	55
SDA 1605V-3	25	15	26	16
SDA 1610V-3	39	29	40	30
SDA 1616V-3	56	46	56	46
SDA 2004V-4	27	17	27	17
SDA 2005V-3	27	17	27	17
SDA 2010V-3	40	30	41	31
SDA 2020V-3	67	57	68	58
SDA 2030V-2	66	56	67	57
SDA 2040V-2	84	74	85	75
SDA 2505V-3	27	17	27	17
SDA 2510V-3	40	30	41	31
SDA 2520V-3	67	57	68	58
SDA 2525V-3	82	72	82	72
SDA 2530V-2	66	56	66	56
SDA 2550V-2	102	92	103	93
SDA 2806V-5	42	30	43	31
SDA 3110V-5	65	50	66	51
SDA 3112V-5	74	59	75	60
SDA 3116V-5	93	78	94	79

Model No.	SDA-V_TT (with thin film seal)		SDA-V_CC (with canvas seal)	
	L ₁	B ₁	L ₁	B ₁
SDA 3120V-5	112	97	113	98
SDA 3132V-2	73	58	74	59
SDA 3205V-4	32	20	32	20
SDA 3210V-5	61	49	62	50
SDA 3610V-5	65	50	66	51
SDA 3612V-5	74	59	75	60
SDA 3616V-5	93	78	94	79
SDA 3620V-5	112	97	113	98
SDA 3636V-2	81	66	83	68
SDA 3810V-5	65	50	66	51
SDA 3812V-5	74	59	75	60
SDA 3816V-5	93	78	94	79
SDA 3820V-5	112	97	113	98
SDA 3825V-4	111	96	112	97
SDA 3830V-3	100	85	101	86
SDA 3840V-2	87	72	89	74
SDA 4510V-5	65	48	66	49
SDA 4512V-5	74	57	75	58
SDA 4516V-5	93	76	94	77
SDA 4520V-5	112	95	113	96
SDA 4525V-4	110	93	112	95
SDA 4530V-4	130	113	132	115
SDA 4540V-3	129	112	130	113
SDA 5010V-5	65	48	66	49
SDA 5012V-5	74	57	75	58
SDA 5016V-5	93	76	94	77
SDA 5020V-5	112	95	113	96
SDA 5025V-4	110	93	112	95
SDA 5030V-4	130	113	131	114
SDA 5040V-3	128	111	130	113
SDA 5050V-2	107	90	108	91

SDAN-V

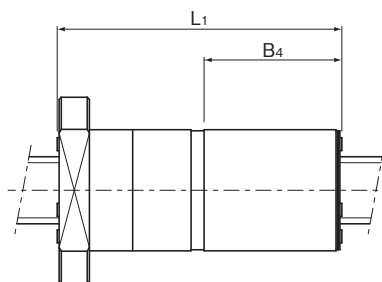

Unit: mm

Model No.	SDAN-V_TT (with thin film seal)		SDAN-V_CC (with canvas seal)	
	L ₁	B ₄	L ₁	B ₄
SDAN 3110V-5	135	62	136	63
SDAN 3112V-5	158	72	159	72
SDAN 3116V-5	189	90	190	91
SDAN 3120V-5	232	109	233	110
SDAN 3610V-5	135	62	136	63
SDAN 3612V-5	158	72	159	72
SDAN 3616V-5	189	90	190	91
SDAN 3620V-5	232	109	233	110
SDAN 3810V-5	135	62	136	63
SDAN 3812V-5	158	71	159	72

Model No.	SDAN-V_TT (with thin film seal)		SDAN-V_CC (with canvas seal)	
	L ₁	B ₄	L ₁	B ₄
SDAN 3816V-5	189	90	190	91
SDAN 3820V-5	232	109	233	110
SDAN 4510V-5	135	62	136	63
SDAN 4512V-5	158	72	159	72
SDAN 4516V-5	189	90	190	91
SDAN 4520V-5	232	109	233	110
SDAN 5010V-5	135	62	136	63
SDAN 5012V-5	158	72	159	72
SDAN 5016V-5	189	90	190	91
SDAN 5020V-5	232	109	233	110

Handling

- (1) Please use at least two people to move any product weighing 20 kg or more, or use a cart or another method of conveyance. Otherwise, it may cause injury or damage the unit.
- (2) Do not disassemble the parts. This will result in loss of functionality.
- (3) Tilting the screw shaft and nut may cause them to fall under their own weight.
- (4) Take care not to drop or strike this product. Otherwise, it may cause injury or damage the unit. Even if there is no outward indication of damage, a sudden impact could prevent the unit from functioning properly.
- (5) When assembling, be sure not to remove the nut from the screw shaft.
- (6) Wear appropriate safety gear, such as protective gloves and safety shoes, when handling the product.

Precautions on Use

- (1) Prevent foreign materials, such as cutting chips or coolant, from entering the product. Failure to do so could damage the product.
- (2) Prevent foreign materials, such as cutting chips, coolant, corrosive solvents, or water from getting in the product by using a bellows or cover when the product is used in an environment where such a thing is likely.
- (3) Do not use this product if the external temperature exceeds 80°C. If used above this temperature, there is a risk that the resin and rubber parts may deform or become damaged (except for the heat-resistant type).
- (4) If foreign materials such as cutting chips adhere to the product, replenish the lubricant after washing the product.
- (5) Slight oscillations can inhibit the formation of an oil film between the raceways and the area of contact for the balls, resulting in fretting. Therefore, be sure to use a type of grease with high fretting resistance. We recommend periodically rotating the nut once to help ensure that a film forms between the raceways and balls.
- (6) Do not forcibly drive a pin, key, or any other positioning device into the product. This could create indentations in the raceways and impair the product's function.
- (7) Skewing or misalignment of the nut and the element that supports the shaft can drastically reduce service life. Inspect the components carefully and make sure they are mounted correctly.
- (8) If any balls fall out of the nut, contact THK. Do not use the product in that condition.
- (9) If the unit will be mounted vertically, install safety equipment or take other measures to prevent it from falling. The nut may fall under its own weight.
- (10) Do not exceed the permissible rotation speed when using the product. This could damage the product or otherwise cause it to malfunction. Please use the product within the range of speeds we have specified.
- (11) Do not allow the nut to overshoot. The product may malfunction if any of the balls fall out, the circulation components become damaged, or any indentations form in the ball raceways. Continuing to use the product under these circumstances may lead to premature wear or damage to the circulation components.
- (12) Use ball screws in conjunction with guide elements such as an LM Guide or ball spline. Failure to do so could damage the product.
- (13) Insufficient rigidity or accuracy of the mounting surface could cause an unexpected load to act on the ball screw, which could lead to premature failure of the product. Therefore, give sufficient consideration to the rigidity and accuracy of the housing and base.

Lubrication

- (1) Thoroughly wipe off anti-rust oil and feed lubricant before using the product.
- (2) Do not mix different lubricants. Even grease containing the same type of thickening agent may, if mixed, interact negatively due to disparate additives or other ingredients.
- (3) When using the product in locations exposed to constant vibrations or in special environments such as in clean rooms, vacuums, and low/high temperatures, use a lubricant suitable for its use/environment.
- (4) When lubricating products that do not feature a grease nipple or oil hole, directly coat the raceways with lubricant and perform several warm-up strokes to ensure that the grease permeates the interior.
- (5) Grease viscosity can vary depending on the temperature. Please keep in mind that the torque of the ball screw may be affected by changes in viscosity.
- (6) After lubrication, the rotational torque of the ball screw may increase due to the stirring resistance of the grease. Be sure to perform a warming-up operation and allow the grease to break in sufficiently before operating the machinery.
- (7) Excess grease may spatter after lubrication. Wipe off spattered grease as necessary.
- (8) Grease deteriorates over time, which decreases the lubricity. Perform regular grease inspections and replenish grease based on frequency of use.
- (9) The greasing interval varies depending on the usage conditions and environment. Grease the system approximately every 100 km of travel distance (3 to 6 months). The final greasing interval/amount should be set at the actual machine.
- (10) Depending on the mounting orientation and nut lubrication port position, the lubricant may not circulate sufficiently. Take note of this during the design process.
- (11) It is necessary to provide adequate lubrication when using ball screws. Using the product without lubrication may increase wear on the rolling elements and shorten the service life.

Storage

When storing the ball screw, pack it as designated by THK and store it indoors in a horizontal position away from high or low temperatures and high humidity. Please note that if the product has been kept in storage for an extended period, the lubricant inside may have deteriorated. Please ensure that you replenish the lubricant before using.

Disposal

The product should be treated as industrial waste and disposed of appropriately.

Recommended Products

High-Speed, Compact Ball Screw Semi-custom **SDA-VZ**

- The nut dimensions comply with ISO, DIN, and JIS standards
- Select stroke length in units of 1 mm.
The shaft end shape and support unit can be selected.
- Eight products are available with a combination of shaft diameters from $\phi 15$ to $\phi 25$ and leads from 5 mm to 20 mm.

Fast delivery products

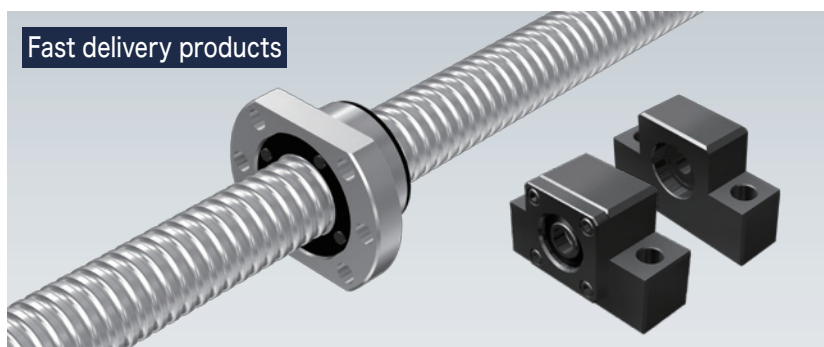

High-Speed, Compact Caged Ball Screw **SDA-V/SDAN-V**

●“LM Guide” and “” are registered trademarks of THK CO., LTD.

- The actual products may differ from the pictures and photographs in this catalog.
- Outward appearances and specifications are subject to change without notice for the purpose of improvement. Please consult with THK before using.
- Although great care has been taken in the production of this catalog, THK will not take any responsibility for damage resulting from typographical errors or omissions.
- For exports of our products and technologies and sales for export, our basic policy is to comply with the Foreign Exchange and Foreign Trade Act and other laws and regulations. Please consult us in advance if you want to export our products by the piece.

All rights reserved

THK CO., LTD.

Headquarters 2-12-10 Shibaura, Minato-ku, Tokyo 108-8506 Japan

International Sales Department Phone: +81-3-5730-3860

www.thk.com

North America

THK America, Inc.

- Headquarters.....Phone: +1-847-310-1111
- Chicago OfficePhone: +1-847-310-1111
- North East Office.....Phone: +1-631-244-1565
- Atlanta Office.....Phone: +1-770-840-7990
- Los Angeles Office.....Phone: +1-949-955-3145
- San Francisco Office.....Phone: +1-925-455-8948
- Detroit Office.....Phone: +1-248-858-9330
- Toronto Office.....Phone: +1-905-820-7800

South America

THK BRAZIL INDUSTRIA E COMERCIO LTDA.

Phone: +55-11-3767-0100

Europe

THK GmbH

- European Headquarters.....Phone: +49-2102-7425-555
- Düsseldorf Office.....Phone: +49-2102-7425-0
- Stuttgart Office.....Phone: +49-7141-4988-500
- U.K. Office.....Phone: +44-1384-471550
- Italy Office.....Phone: +39-02-9901-1801

- Sweden Office.....Phone: +46-8-445-7630
- Austria Office.....Phone: +43-7229-51400
- Spain Office.....Phone: +34-93-652-5740
- Turkey Office.....Phone: +90-216-362-4050
- Prague Office.....Phone: +420-2-41025-100
- Moscow Office.....Phone: +7-495-649-80-47
- THK Europe B.V.
- Eindhoven Office.....Phone: +31-40-290-9500
- THK France S.A.S.
- Paris Office.....Phone: +33-1-7425-3800

China

THK (CHINA) CO., LTD.

- Headquarters.....Phone: +86-411-8733-7111
- Shanghai Branch.....Phone: +86-21-6219-3000
- Beijing Branch.....Phone: +86-10-8441-7277
- Chengdu Branch.....Phone: +86-28-8526-8025
- Guangzhou Branch.....Phone: +86-20-8523-8418
- Shenzhen Branch.....Phone: +86-755-2642-9587
- Xian Branch.....Phone: +86-29-8834-1712
- THK (SHANGHAI) CO., LTD.Phone: +86-21-6275-5280

Taiwan

THK TAIWAN CO., LTD.

- Taipei Headquarters.....Phone: +886-2-2888-3818
- Taichung Office.....Phone: +886-4-2359-1505
- Tainan Office.....Phone: +886-6-289-7668

South Korea

- Seoul Representative Office.....Phone: +82-2-3468-4351

Singapore

THK LM System Pte. Ltd.....Phone: +65-6884-5500

Thailand

THK RHYTHM (THAILAND) CO., LTD. LM System Division

- Bangkok Branch.....Phone: +66-2751-3001

India

THK India Pvt. Ltd.

- Headquarters & Bengaluru Branch.....Phone: +91-80-2340-9934
- Pune Branch.....Phone: +91-72-7600-2071
- Chennai Branch.....Phone: +91-44-4042-3132
- Ahmedabad Branch.....Phone: +91-79-6134-4925
- Delhi Branch.....Phone: +91-12-4676-8695