

# SCR

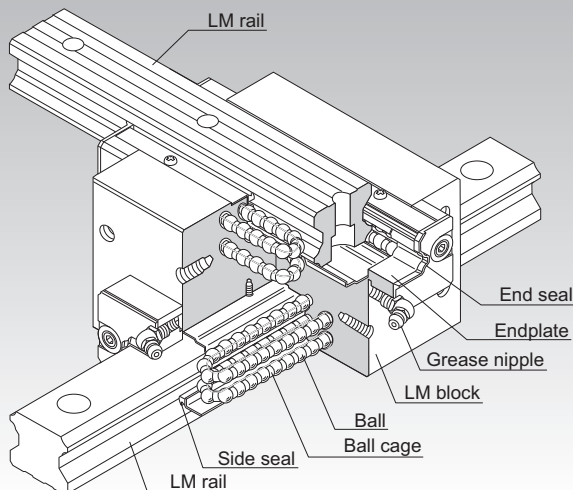

## Caged Ball LM Guide Cross LM Guide Model SCR



\*For the ball cage, see **A1-88**.

**Point of Selection** **A1-10**

**Point of Design** **A1-436**

**Options** **A1-459**

**Model No.** **A1-524**

**Precautions on Use** **A1-530**

**Accessories for Lubrication** **A24-1**

**Mounting Procedure and Maintenance** **B1-89**

Equivalent moment factor **A1-43**

Rated Loads in All Directions **A1-58**

Equivalent factor in each direction **A1-60**

Radial Clearance **A1-70**

Accuracy Standards **A1-79**

Shoulder Height of the Mounting Base and the Corner Radius **A1-446**

Permissible Error of the Mounting Surface **A1-452**

Dimensions of Each Model with an Option Attached **A1-472**

---

## Structure and Features

---

Balls roll in four rows of raceways precision-ground on an LM rail and an LM block, and ball cages and endplates incorporated in the LM block allow the balls to circulate.

This model is an integral type of Caged Ball LM Guide that squares an internal structure similar to model SHS, which has a proven track record and is highly reliable, with another and uses two LM rails in combination. Since an orthogonal LM system can be achieved with model SCR alone, a conventionally required saddle is no longer necessary, the structure for X-Y motion can be simplified and the whole system can be downsized.

### [4-way Equal Load]

Each row of balls is placed at a contact angle of  $45^\circ$  so that the rated loads applied to the LM block are uniform in the four directions (radial, reverse radial and lateral directions), enabling the LM Guide to be used in all orientations and in extensive applications.

### [High Rigidity]

Since balls are arranged in four rows in a well-balanced manner, this model is stiff against a moment, and smooth straight motion is ensured even a preload is applied to increase the rigidity.

Since the rigidity of the LM block is higher than that of a combination of two LM blocks of the conventional type secured together back-to-back with bolts, this model is optimal for building an X-Y table that requires a high rigidity.

### [Compact]

This model is an integral type of Caged Ball LM Guide that squares an internal structure similar to model SHS, which has a proven track record and is highly reliable, with another and uses two LM rails in combination. Since an orthogonal LM Guide can be achieved with model SCR alone, a conventionally required saddle is no longer necessary, the structure for X-Y motion can be simplified and the whole system can be downsized.

## Types and Features

### Model SCR

Specification Table⇒ **A1-168**

This model is a standard type.

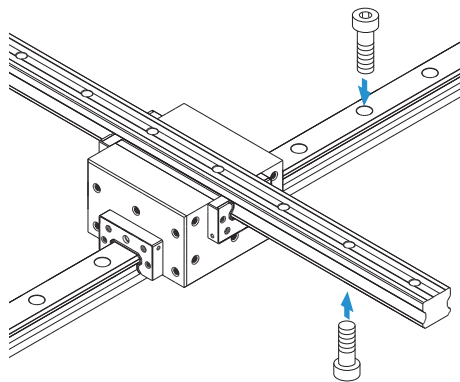

#### Drawing of Using an Inner Saddle

Model SCR can easily be assembled and adjusted by using an inner saddle to link four LM blocks together. When installed on an inner saddle, model SCR achieves a highly accurate X-Y guide and high rigidity moment in the yawing direction  (as indicated by the arrow in the figure).

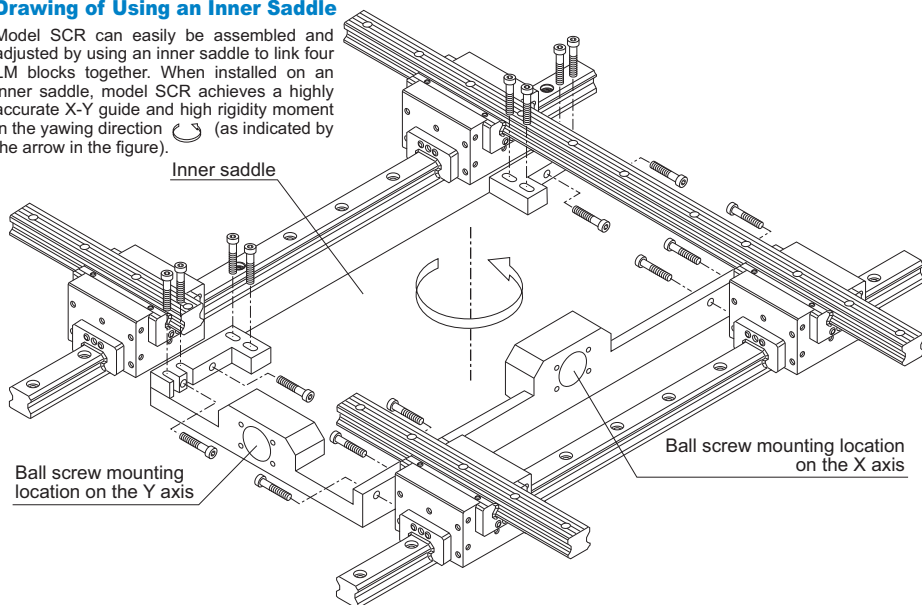



# Model SCR

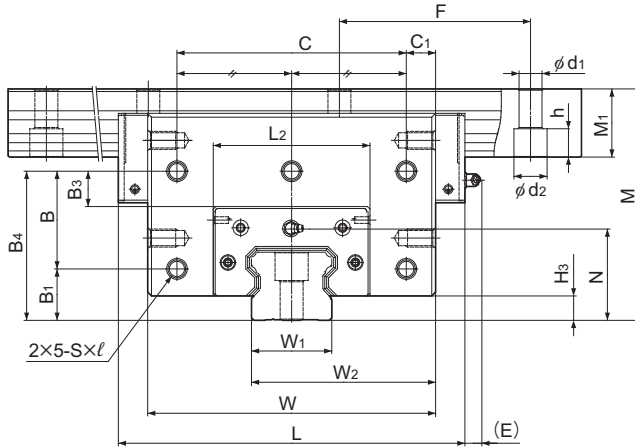

Model No.	Outer dimensions			LM block dimensions										
	Height	Width	Length											
	M	W	L	B <sub>1</sub>	B <sub>3</sub>	B <sub>4</sub>	B	C	C <sub>1</sub>	S×ℓ	L <sub>2</sub>	H <sub>3</sub>	N	E
SCR 15S	47	48	64.4	—	11.3	34.8	—	20	14	M4×6	33.4	3	18.5	5.5
SCR 20S	57	59	79	—	13	42.5	—	30	14.5	M5×8	43	4.6	23.5	12
SCR 20	57	78	98	13	7.5	37	24	56	11	M5×8	43	4.6	23.5	12
SCR 25	70	88	109	18	9	44	26	64	12	M6×10	47.4	5.8	28.5	12
SCR 30	82	105	131	21	12	53	32	76	14.5	M6×10	58	7	34	12
SCR 35	95	123	152	24	14	61	37	90	16.5	M8×14	68	7.5	40	12
SCR 45	118	140	174	30	16.5	75	45	110	15	M10×15	84.6	8.9	49.5	16
SCR 65	180	226	272	40	27.5	116	76	180	23	M14×22	123	19	71	16

## Model number coding

**4 SCR25 QZ KKHH C0 +1200/1000L P**

4	SCR25	QZ	KKHH	C0	+1200/1000L	P
Total No. of LM blocks	Model number	With QZ Lubricator	Contamination protection accessory symbol (*1) Radial clearance symbol (*2) Normal (No symbol)/Light preload (C1) Medium preload (C0)	LM rail length on the X axis (in mm)	LM rail length on the Y axis (in mm)	Accuracy symbol (*3) Precision grade (P) Super precision grade (SP) Ultra precision grade (UP)

(\*1) See contamination protection accessory on **A1-496**. (\*2) See **A1-70**. (\*3) See **A1-79**.

Note) Those models equipped with QZ Lubricator cannot have a grease nipple. When desiring a grease nipple for a model attached with QZ, contact THK.

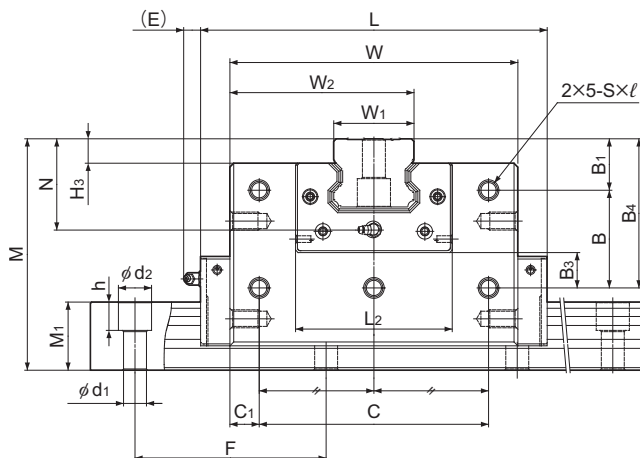

Unit: mm

	Grease nipple	LM rail dimensions					Basic load rating		Static permissible moment*		Mass	
		Width $W_1$ 0 -0.05	$W_2$	Height $M_1$	Pitch $F$	Mounting hole $d_1 \times d_2 \times h$	$C$ kN	$C_0$ kN	$M_0$ kN-m	$M_b$ kN-m	LM block kg	LM rail kg/m
	PB-1021B	15	31.5	13	60	4.5×7.5×5.3	14.2	24.2	0.16	0.175	0.54	1.3
	B-M6F	20	39.5	16.5	60	6×9.5×8.5	22.3	38.4	0.334	0.334	0.88	2.3
	B-M6F	20	49	16.5	60	6×9.5×8.5	28.1	50.3	0.473	0.568	1.7	2.3
	B-M6F	23	55.5	20	60	7×11×9	36.8	64.7	0.696	0.848	3.4	3.2
	B-M6F	28	66.5	23	80	9×14×12	54.2	88.8	1.15	1.36	4.6	4.5
	B-M6F	34	78.5	26	80	9×14×12	72.9	127	2.01	2.34	6.8	6.2
	B-PT1/8	45	92.5	32	105	14×20×17	100	166	3.46	3.46	10.8	10.4
	B-PT1/8	63	144.5	53	150	18×26×22	253	408	11.9	13.3	44.5	23.7

Note) Static permissible moment\*: Static permissible moment value with 1 LM block

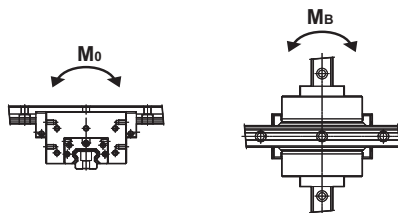

## Standard Length and Maximum Length of the LM Rail

Table1 shows the standard and maximum lengths of the SCR model rail. If a rail length longer than the listed max length is required, rails may be jointed to meet the overall length. Contact THK for details. For special rail lengths, it is recommended to use a value corresponding to the G dimension from the table. As the G dimension increases, this portion becomes less stable and the accuracy performance is severely impacted.

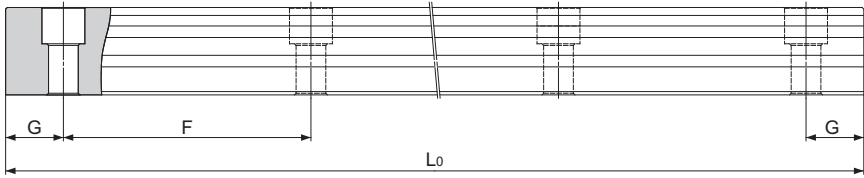

Table1 Standard Length and Maximum Length of the LM Rail for Model SCR

Unit: mm

Model No.	SCR 15	SCR 20	SCR 25	SCR 30	SCR 35	SCR 45	SCR 65
LM rail standard length (L <sub>0</sub> )	160	220	220	280	280	570	1270
	220	280	280	360	360	675	1570
	280	340	340	440	440	780	2020
	340	400	400	520	520	885	2620
	400	460	460	600	600	990	
	460	520	520	680	680	1095	
	520	580	580	760	760	1200	
	580	640	640	840	840	1305	
	640	700	700	920	920	1410	
	700	760	760	1000	1000	1515	
	760	820	820	1080	1080	1620	
	820	940	940	1160	1160	1725	
	940	1000	1000	1240	1240	1830	
	1000	1060	1060	1320	1320	1935	
	1060	1120	1120	1400	1400	2040	
	1120	1180	1180	1480	1480	2145	
	1180	1240	1240	1560	1560	2250	
	1240	1360	1300	1640	1640	2355	
	1360	1480	1360	1720	1720	2460	
	1480	1600	1420	1800	1800	2565	
1600	1720	1480	1880	1880	2670		
	1840	1540	1960	1960	2775		
	1960	1600	2040	2040	2880		
	2080	1720	2200	2200	2985		
	2200	1840	2360	2360	3090		
		1960	2520	2520			
		2080	2680	2680			
		2200	2840	2840			
		2320	3000	3000			
		2440					
Standard pitch F	60	60	60	80	80	105	150
G	20	20	20	20	20	22.5	35
Max length	3000	3000	3000	3000	3000	3090	3000

## Tapped-hole LM Rail Type of Model SCR

The model SCR variations include a type with its LM rail bottom tapped. With the X-axis LM rail having tapped holes, this model can be secured with bolts from the top.

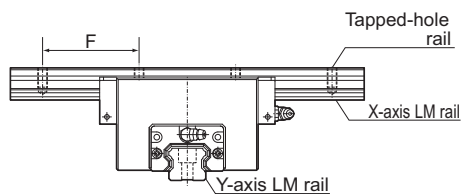

Table2 Dimensions of the LM Rail Tap Unit: mm

Model No.	Tap diamete	Tap depth
15	M5	8
20	M6	10
25	M6	12
30	M8	15
35	M8	17
45	M12	20
65	M20	30

### Model number coding

**4 SCR35 KKHH C0 +1000L P K/1000L P**

Symbol for  
tapped-hole LM rail type