

Rolled Ball Screw

Models JPF, BTK-V, MTF, WHF, BLK/WTF, CNF and BNT

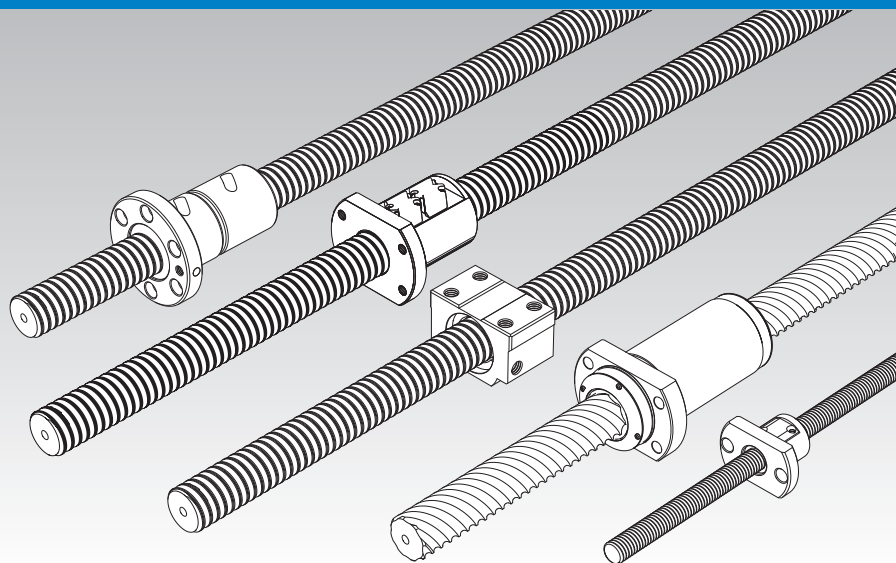

Point of Selection **A15-8**

Options **A15-352**

Model No. **A15-369**

Precautions on Use **A15-374**

Accessories for Lubrication **A24-1**

Mounting Procedure and Maintenance **B15-104**

Lead Angle Accuracy **A15-11**

Accuracy of the Mounting Surface **A15-14**

Axial Clearance **A15-19**

Maximum Length of the Screw Shaft **A15-24**

DN Value **A15-33**

Support Unit **A15-316**

Recommended Shapes of Shaft Ends **A15-324**

Dimensions of Each Model with an Option Attached **A15-360**

Structure and Features

THK Rolled Ball Screws are low priced feed screws that use a screw shaft rolled with high accuracy and specially surface-ground, instead of a thread-ground shaft used in the Precision Ball Screws.

The ball raceways of the ball screw nut are all thread-ground, thus to achieve a smaller axial clearance and smoother motion than the conventional rolled ball screw.

In addition, a wide array of types are offered as standard in order to allow optimal products to be selected according to the application.

[Achieves Lead Angle Accuracy of Class C7]

Screw shafts with travel distance error of classes C7 and C8 are also manufactured as the standard in addition to class C10 to meet a broad range of applications.

Travel distance	C7 : $\pm 0.05/300$ (mm)
	C8 : $\pm 0.10/300$ (mm)
	C10: $\pm 0.21/300$ (mm)

(For maximum length of screw shaft by accuracy grade, see **A15-25**.)

[Achieves Roughness of the Ball Raceways of the Screw Shaft at 0.20 a or Less]

The surface of the screw shaft's ball raceways is specially ground after the shaft is rolled to ensure surface roughness of 0.20 a or less, which is equal to that of the ground thread of the Precision Ball Screw.

[The Ball Raceways of the Ball Screw Nut are Finished by Grinding]

THK finishes the ball raceways of Rolled Ball Screw nuts by grinding, just as the Precision Ball Screws, to secure the durability and the smooth motion.

[Low Price]

The screw shaft is induction-hardened or carburized after being rolled, and its surface is then specially ground. This allows the rolled Ball Screw to be priced lower than the Precision Ball Screw with a ground thread.

[Effects of high levels of dustproofing]

The ball screw nut is incorporated with a compact labyrinth seal or a brush seal. This achieves low friction, high dust-prevention effect and a longer service life of the Ball Screw.

Types and Features

[Preload Type]

Model JPF

Specification Table⇒ **A15-288**

This model achieves zero-backlash through a constant preloading method by shifting the phase, with the central part of the nut as a spring structure.

The constant preload method allows the ball screw to absorb a pitch error and achieve a smooth motion.

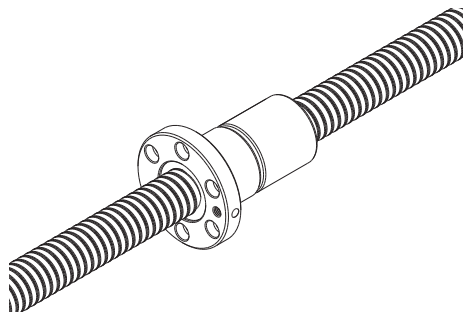

Axial clearance: 0 or less

● Direction of applied load

The direction of the applied load during use must be in the recommended loading direction indicated in the figure. If a load is applied in the opposite direction, it may cause the spring structure to fracture, and therefore, the applied load must be $0.1 \times C_a$ or less during use.

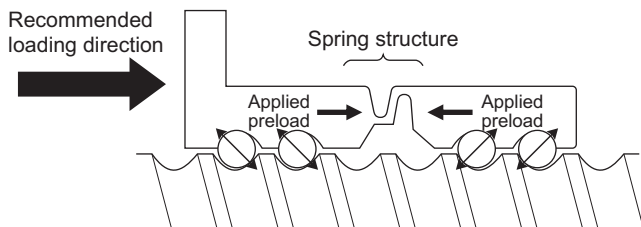

[No Preload Type]

Model BTK-V

Specification Table⇒ **A15-290**

This Rolled Ball Screw feed achieves a DN value of 100,000 by using a new circulation structure.

Since the nut outer diameter and the mounting holes of this model are dimensionally interchangeable with the previous model BTK, model BTK can be replaced with this model.

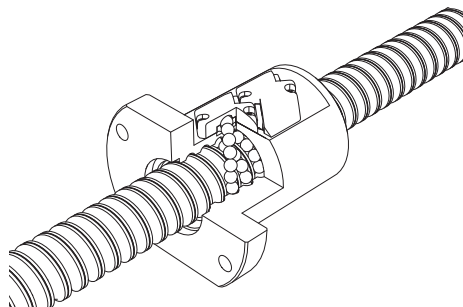

Model MTF

A miniature type with a screw shaft diameter of $\phi 6$ to $\phi 12$ mm and a lead of 1 to 2 mm.

Specification Table \Rightarrow **A15-290**

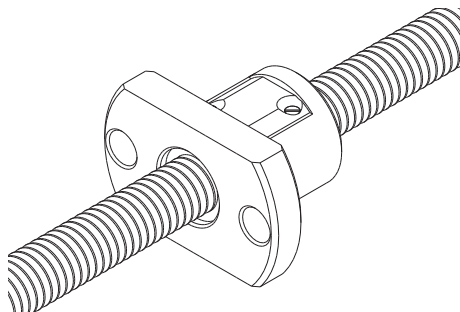

Model WHF

This Ball Screw for high-speed feed achieves a DN value of 100,000 by using a new circulation structure.

Since the nut outer diameter and the mounting holes of this model are dimensionally interchangeable with the previous model WTF, model WTF can be replaced with this model. (WHF1530, WHF2040 and WHF2550)

Specification Table \Rightarrow **A15-290**

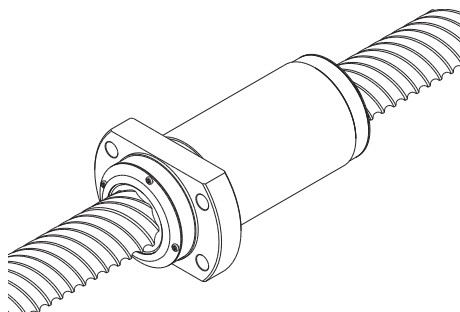

Models BLK/WTF

Using an end-cap method, these models achieve stable motion in a high-speed rotation.

Specification Table \Rightarrow **A15-290**

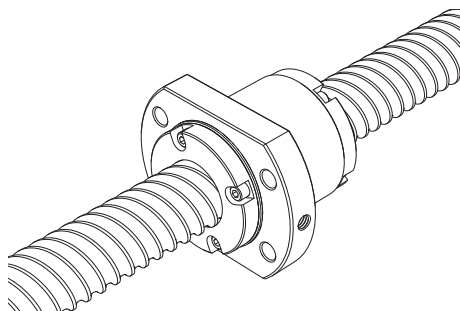

Model CNF

Specification Table⇒ **A15-290**

With a combination of 4 rows of large-lead load-
ed grooves and a long nut, a long service life is
achieved.

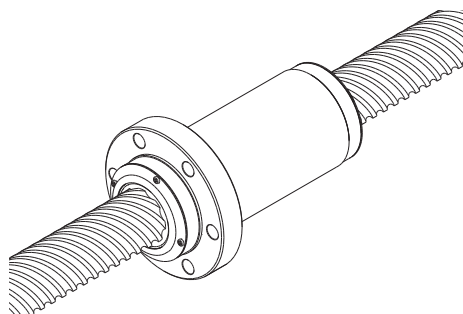

Square Ball Screw Nut Model BNT

Specification Table⇒ **A15-296**

Since the mounting screw holes are machined
on the square ball screw nut, this model can
compactly be mounted on the machine without
a housing.

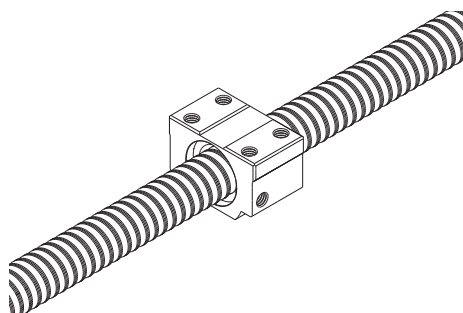

Preload Type of Rolled Ball Screw

Screw shaft outer diameter	14 to 40
Lead	4 to 10

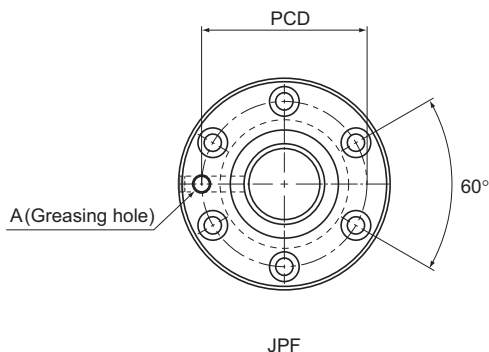

Screw shaft outer diameter d	Lead Ph	Model No.	Ball center-to-center diameter dp	Thread minor diameter dc	No. of loaded circuits Rows x turns	Basic load rating		Outer diameter D
						Ca kN	C _{0a} kN	
14	4	JPF 1404-4	14.4	11.5	2 × 1	2.8	5.1	26
	5	JPF 1405-4	14.5	11.2	2 × 1	3.9	8.6	26
16	5	JPF 1605-4	16.75	13.5	2 × 1	3.7	8.2	30
20	5	JPF 2005-6	20.5	17.2	3 × 1	6	16	34
25	5	JPF 2505-6	25.5	22.2	3 × 1	6.9	20.8	40
	10	JPF 2510-4	26.8	20.2	2 × 1	11.4	24.5	47
28	5	JPF 2805-6	28.75	25.2	3 × 1	7.3	23.9	43
	6	JPF 2806-6	28.5	25.2	3 × 1	7.3	23.9	43
32	10	JPF 3210-6	33.75	27.2	3 × 1	19.3	49.9	54
36	10	JPF 3610-6	37	30.5	3 × 1	20.6	56.2	58
40	10	JPF 4010-6	41.75	35.2	3 × 1	22.2	65.3	62

Note) The ball screw nut and the screw shaft of model JPF are not sold separately.

The basic load rating corresponds to the recommended loading direction.

If a load is applied in the opposite direction, the value must be 0.1 x Ca or less during use (see [A15-284](#)).

Model number coding

JPF1404-4 RR +500L C7 T

Model number Overall screw shaft length (in mm) Symbol for rolled shaft

Seal symbol (*1) Accuracy symbol (*2)

(*1) See [A15-352](#). (*2) See [A15-12](#).

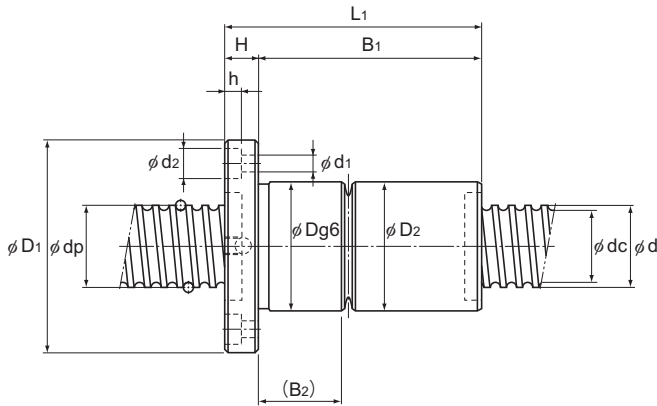

JPF

Unit: mm

Nut dimensions										Screw shaft inertial moment/mm ⁴	Nut mass kg	Shaft mass kg/m
Flange diameter	Outer diameter	Overall length	H	B ₁	B ₂	PCD	d ₁ × d ₂ × h	Greasing hole	A			
D ₁	D ₂	L ₁								kg·cm ² /mm		
46	25.5	52	10	42	16.5	36	4.5 × 8 × 4.5	M6		2.96 × 10 ⁻⁴	0.22	1.0
46	25.5	60	10	50	20	36	4.5 × 8 × 4.5	M6		2.96 × 10 ⁻⁴	0.24	0.99
49	29.5	60	10	50	19.5	39	4.5 × 8 × 4.5	M6		5.05 × 10 ⁻⁴	0.3	1.34
57	33.5	80	11	69	26.5	45	5.5 × 9.5 × 5.5	M6		1.23 × 10 ⁻³	0.46	2.15
66	39.5	80	11	69	26	51	5.5 × 9.5 × 5.5	M6		3.01 × 10 ⁻³	0.6	3.45
72	46.5	112	12	100	42	58	6.6 × 11 × 6.5	M6		3.01 × 10 ⁻³	1.2	3.26
69	42.5	80	12	68	25	55	6.6 × 11 × 6.5	M6		4.74 × 10 ⁻³	0.66	4.27
69	42.5	90	12	78	35	55	6.6 × 11 × 6.5	M6		4.74 × 10 ⁻³	0.72	4.44
88	53.5	135	15	120	53.5	70	9 × 14 × 8.5	M6		8.08 × 10 ⁻³	1.84	5.49
98	57.5	138	18	120	53.5	77	11 × 17.5 × 11	M6		1.29 × 10 ⁻²	2.22	6.91
104	61.5	138	18	120	53.5	82	11 × 17.5 × 11	PT 1/8		1.97 × 10 ⁻²	2.42	8.81

No Preload Type of Rolled Ball Screw

Screw shaft outer diameter	6 to 16
Lead	1 to 30

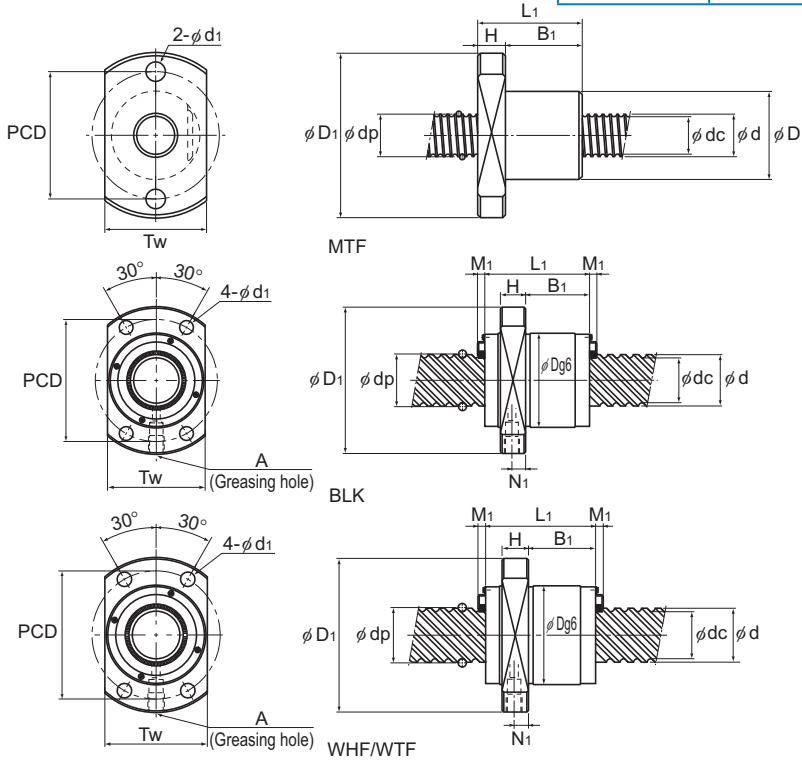

Screw shaft outer diameter d	Lead Ph	Model No.	Ball center-to-center diameter dp	Thread minor diameter dc	No. of loaded circuits Rows x turns	Basic load rating		Rigidity K	Outer diameter	
						Ca	C _a		N/μm	D
6	1	MTF 0601-3.7	6.15	5.3	1×3.7	0.7	1.2	70	13	30
8	2	MTF 0802-3.7	8.3	6.6	1×3.7	2.1	3.8	90	20	40
10	2	MTF 1002-3.7	10.3	8.6	1×3.7	2.3	4.8	110	23	43
	6	BTK 1006V-2.6	10.5	7.8	1×2.65	2.8	4.9	88	26	42
12	2	MTF 1202-3.7	12.3	10.6	1×3.7	2.5	5.8	130	25	47
	8	BTK 1208V-2.6	12.65	9.7	1×2.65	3.8	6.8	108	29	45
14	4	BTK 1404V-3.6	14.4	11.5	1×3.65	5.5	11.5	150	31	50
	5	BTK 1405V-2.6	14.5	11.2	1×2.65	5	11.4	116	32	50
15	10	BLK 1510-5.6	15.75	12.5	2×2.8	9.8	25.2	260	34	57
	20	WTF 1520-3	15.75	12.5	2×1.5	5.5	14.2	140	32	53
		WTF 1520-6	15.75	12.5	4×1.5	10.1	28.5	280	32	53
	30	WTF 1530-2	15.75	12.5	4×0.6	4.3	9.3	120	32	53
		WTF 1530-3	15.75	12.5	2×1.6	5.6	12.4	160	32	53
		WTF 1530-4	15.75	12.5	2×1.7	5.5	12.2	195	32	53
		CNF 1530-6	15.75	12.5	4×1.6	10.1	24.7	310	32	53
16	5	BTK 1605V-2.6	16.75	13.5	1×2.65	5.4	13.3	130	34	54
	16	BLK 1616-3.6	16.65	13.7	2×1.8	5.8	12.9	170	32	53
		BLK 1616-7.2	16.65	13.7	4×1.8	10.5	25.9	340	32	53

Note) Model MTF cannot be attached with seal.

Model MTF is only sold as sets (ball screw nut and screw shaft).

Model MTF is applied only with anti-rust oil.

WHF is available on a made-to-order basis. If planning to use this model, contact THK.

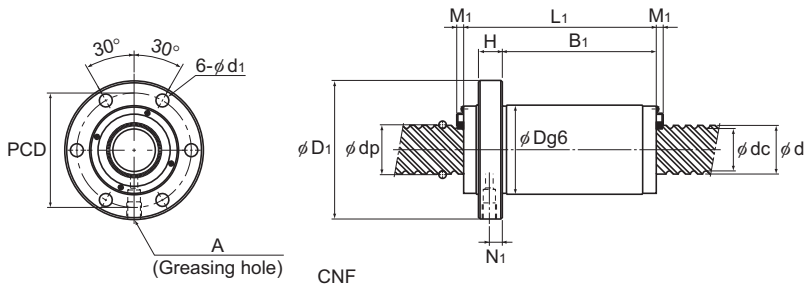

CNF

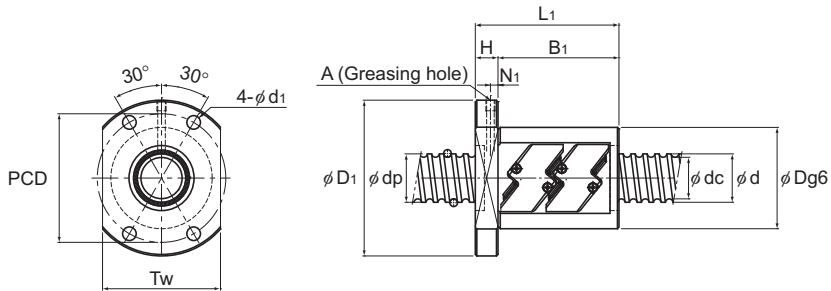

BTK-V

Unit: mm

Nut dimensions							Greasing hole	Seal	Axial clearance	Standard shaft length	Screw shaft inertial moment/mm	Nut mass	Shaft mass
Overall length	H	B ₁	PCD	d ₁	T _w	N ₁							
21	5	16	21.5	3.4	17	—	—	—	0.05	150, 250	9.99×10^{-6}	0.03	0.19
28	6	22	30	4.5	24	—	—	—	0.05		3.16×10^{-5}	0.08	0.31
28	6	22	33	4.5	27	—	—	—	0.05	200, 300	7.71×10^{-5}	0.1	0.52
36	8	28	34	4.5	29	—	3	—	0.05		7.71×10^{-5}	0.12	0.48
30	8	22	36	5.5	29	—	—	—	0.05	500, 1000	1.6×10^{-4}	0.13	0.77
44	8	36	37	4.5	32	—	3	—	0.05		1.6×10^{-4}	0.18	0.72
40	10	30	40	4.5	37	5	M6	—	0.1	500, 1000	2.96×10^{-4}	0.23	1.0
40	10	30	40	4.5	38	5	M6	—	0.1		2.96×10^{-4}	0.22	0.99
44	10	24	45	5.5	40	5	M6	3.5	0.1	500, 1000	3.9×10^{-4}	0.26	1.16
45	10	28	43	5.5	33	5	M6	3.5	0.1		3.9×10^{-4}	0.20	1.17
45	10	28	43	5.5	33	5	M6	3.5	0.1	500, 1000	3.9×10^{-4}	0.20	1.17
33	10	17	43	5.5	33	5	M6	3.5	0.1		3.9×10^{-4}	0.22	1.19
63	10	47	43	5.5	33	5	M6	3.5	0.1	500, 1000	3.9×10^{-4}	0.4	1.19
64.5	10	47.5	43	5.5	33	5	M6	3.5	0.1		3.9×10^{-4}	0.38	1.26
63	10	47	43	5.5	—	5	M6	3.5	0.1	500, 1000	3.9×10^{-4}	0.42	1.19
40	10	30	44	4.5	40	5	M6	—	0.1		5.05×10^{-4}	0.24	1.34
38	10	21.5	42	4.5	38	5	M6	3.5	0.1	500, 1000	5.05×10^{-4}	0.21	1.35
38	10	21.5	42	4.5	38	5	M6	3.5	0.1		5.05×10^{-4}	0.25	1.35

No Preload Type of Rolled Ball Screw

Screw shaft outer diameter	18 to 30
Lead	5 to 60

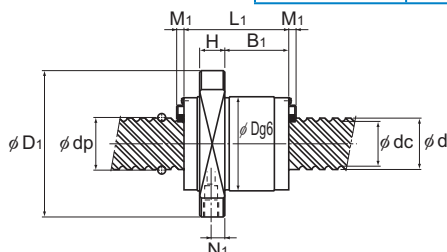
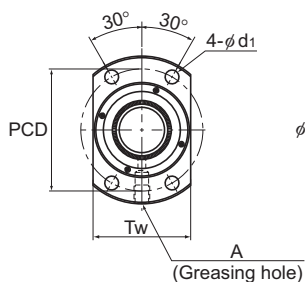

WHF2020,2525/BLK

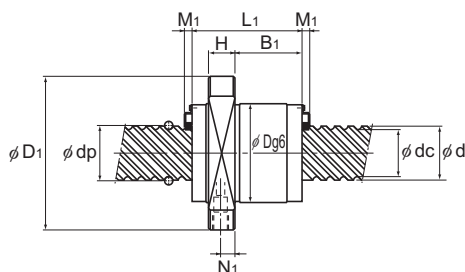
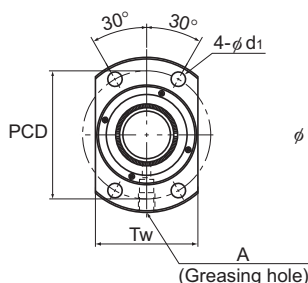

WHF2040,2550/WTF

Screw shaft outer diameter d	Lead Ph	Model No.	Ball center-to-center diameter dp	Thread minor diameter dc	No. of loaded circuits Rows X turns	Basic load rating		Rigidity K	Outer diameter		
						Ca kN	C _{0a} kN		N/μm	D	Flange diameter D ₁
18	8	BTK 1808V-3.6	19.3	14.4	1 × 3.65	13.1	31	210	50	80	
20	5	BTK 2005V-2.6	20.5	17.2	1 × 2.65	6	16.5	150	40	60	
	10	BTK 2010V-2.6	21.25	16.4	1 × 2.65	10.6	25.1	160	52	82	
		WHF 2020-3.4	20.75	17.5	2 × 1.7	6.6	18.9	225	42	64	
		BLK 2020-3.6	20.75	17.5	2 × 1.8	7.7	22.3	210	39	62	
		BLK 2020-7.2	20.75	17.5	4 × 1.8	13.9	44.6	410	39	62	
	20	40	WTF 2040-2	20.75	17.5	4 × 0.65	5.4	13.6	160	37	57
			WTF 2040-3	20.75	17.5	2 × 1.65	6.6	17.2	200	37	57
			WHF 2040-3.4	20.75	17.5	2 × 1.7	6.6	17.2	256	37	62
			CNF 2040-6	20.75	17.5	4 × 1.65	12	34.4	400	37	57
	25	5	BTK 2505V-2.6	25.5	22.2	1 × 2.65	6.7	20.8	180	43	67
10		BTK 2510V-5.3	26.8	20.2	2 × 2.65	31.2	83.7	400	60	96	
		WHF 2525-3.4	26	21.9	2 × 1.7	10.5	29.9	285	50	77	
		BLK 2525-3.6	26	21.9	2 × 1.8	12.1	35	270	47	74	
		BLK 2525-7.2	26	21.9	4 × 1.8	21.9	69.9	520	47	74	
25		50	WTF 2550-2	26	21.9	4 × 0.65	8.5	21.2	200	45	69
			WTF 2550-3	26	21.9	2 × 1.65	10.4	26.9	260	45	69
			WHF 2550-3.4	26	21.9	2 × 1.7	10.4	27.1	323	45	69
			CNF 2550-6	26	21.9	4 × 1.65	18.9	53.9	460	45	69
28		6	BTK 2806V-2.6	28.5	25.2	1 × 2.65	7	23.4	200	50	80
	BTK 2806V-5.3		28.5	25.2	2 × 2.65	12.8	46.8	390	50	80	
30	60	WTF 3060-2	31.25	26.4	4 × 0.65	11.8	30.6	240	55	89	
		WTF 3060-3	31.25	26.4	2 × 1.65	14.5	38.9	310	55	89	
		CNF 3060-6	31.25	26.4	4 × 1.65	26.2	77.7	600	55	89	

Note) WHF is available on a made-to-order basis. If planning to use this model, contact THK.

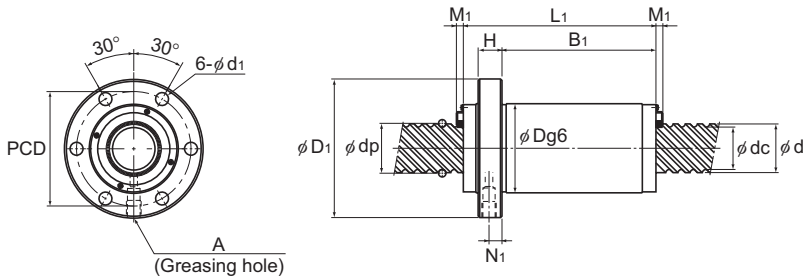

CNF

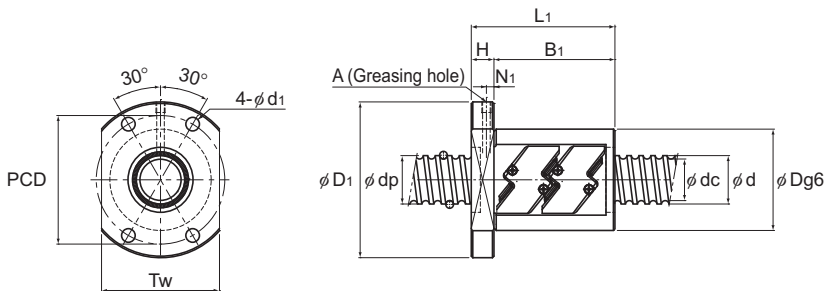

BTK-V

Unit: mm

Overall length	Nut dimensions									Axial clearance	Standard shaft length	Screw shaft inertial moment/mm ³	Nut mass	Shaft mass
	L ₁	H	B ₁	PCD	d ₁	T _w	Greasing hole		Seal					
							N ₁	A						
61	12	49	65	6.6	60	5	M6	—	0.1	500, 1000	8.09 × 10 ⁻⁴	0.84	1.71	
40	10	30	50	4.5	46	5	M6	—	0.1		1.23 × 10 ⁻³	0.32	2.15	
61	12	49	67	6.6	64	5	M6	—	0.1	500, 1000, 1500	1.23 × 10 ⁻³	0.93	2.16	
47.1	10	24.1	53	5.5	46	5	M6	3.5	0.1		1.23 × 10 ⁻³	0.49	2.25	
45	10	27.5	50	5.5	46	5	M6	3.5	0.1		1.23 × 10 ⁻³	0.35	2.18	
45	10	27.5	50	5.5	46	5	M6	3.5	0.1		1.23 × 10 ⁻³	0.35	2.18	
41.5	10	25.5	47	5.5	38	5.5	M6	3.5	0.1		1.23 × 10 ⁻³	0.25	2.12	
81.5	10	65.5	47	5.5	38	5.5	M6	3.5	0.1		1.23 × 10 ⁻³	0.5	2.12	
82.7	10	65.7	50	5.5	46	5	M6	3.5	0.1		1.23 × 10 ⁻³	0.58	2.34	
81	10	65	47	5.5	—	5.5	M6	3.5	0.1		1.23 × 10 ⁻³	0.5	2.12	
40	10	30	55	5.5	50	5	M6	—	0.1		3.01 × 10 ⁻³	0.34	3.45	
98	15	83	78	9	72	5	M6	—	0.1		3.01 × 10 ⁻³	1.83	3.26	
58.8	12	31.3	63	6.6	56	6	M6	3.5	0.1		3.01 × 10 ⁻³	0.65	3.52	
55	12	35	60	6.6	56	6	M6	3.5	0.1		3.01 × 10 ⁻³	0.64	3.41	
55	12	35	60	6.6	56	6	M6	3.5	0.1	3.01 × 10 ⁻³	0.64	3.41		
52	12	31.5	57	6.6	46	7	M6	3.5	0.1	3.01 × 10 ⁻³	0.45	3.34		
102	12	81.5	57	6.6	46	7	M6	3.5	0.1	3.01 × 10 ⁻³	0.85	3.34		
103.2	12	79.3	57	6.6	46	6	M6	3.5	0.1	3.01 × 10 ⁻³	0.72	3.66		
102	12	81.5	57	6.6	—	7	M6	3.5	0.1	3.01 × 10 ⁻³	0.85	3.34		
47	12	35	65	6.6	60	6	M6	—	0.1	4.74 × 10 ⁻³	0.59	4.44		
65	12	53	65	6.6	60	6	M6	—	0.1	4.74 × 10 ⁻³	0.75	4.44		
62.5	15	37.5	71	9	56	9	M6	3.8	0.14	6.24 × 10 ⁻³	0.8	4.84		
122.5	15	97.5	71	9	56	9	M6	3.8	0.14	6.24 × 10 ⁻³	1.7	4.84		
122	15	97	71	9	—	9	M6	3.8	0.14	6.24 × 10 ⁻³	1.7	4.84		

No Preload Type of Rolled Ball Screw

Screw shaft outer diameter	32 to 50
Lead	10 to 100

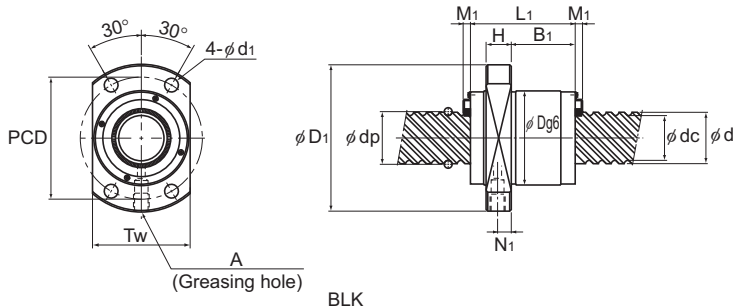

Screw shaft outer diameter d	Lead Ph	Model No.	Ball center-to-center diameter dp	Thread minor diameter dc	No. of loaded circuits Rows X turns	Basic load rating		Rigidity K		
						Ca	C _a		Outer diameter D	Flange diameter D _f
						kN	kN	N/μm	D	D _f
32	10	BTK 3210V-2.6	33.75	27.2	1×2.65	19.8	53.8	250	67	103
		BTK 3210V-5.3	33.75	27.2	2×2.65	36	107.5	490	67	103
	32	BLK 3232-3.6	33.25	28.3	2×1.8	17.3	53.9	330	58	92
		BLK 3232-7.2	33.25	28.3	4×1.8	31.3	107.8	650	58	92
36	10	BTK 3610V-2.6	37	30.5	1×2.65	20.8	59.8	270	70	110
		BTK 3610V-5.3	37	30.5	2×2.65	37.8	118.7	530	70	110
	20	BLK 3620-5.6	37.75	31.2	2×2.8	39.8	121.7	570	70	110
		BLK 3624-5.6	38	30.7	2×2.8	46.2	137.4	590	75	115
	36	BLK 3636-3.6	37.4	31.7	2×1.8	22.4	70.5	370	66	106
		BLK 3636-7.2	37.4	31.7	4×1.8	40.6	141.1	730	66	106
40	10	BTK 4010V-5.3	41.75	35.2	2×2.65	40.3	134.9	590	76	116
	40	BLK 4040-3.6	41.75	35.2	2×1.8	28.1	89.8	420	73	114
		BLK 4040-7.2	41.75	35.2	4×1.8	51.1	179.6	810	73	114
		WTF 4080-2	41.75	35.2	4×0.65	19.8	54.5	320	73	114
	80	WTF 4080-3	41.75	35.2	2×1.65	24.3	69.2	400	73	114
45	12	BTK 4512V-5.3	46.5	39.2	2×2.65	49.5	169	650	82	128
50	16	BTK 5016V-5.3	52.7	42.9	2×2.65	93.8	315.2	930	102	162
		BLK 5050-3.6	52.2	44.1	2×1.8	42.1	140.4	510	90	135
	50	BLK 5050-7.2	52.2	44.1	4×1.8	76.3	280.7	1000	90	135
		WTF 50100-2	52.2	44.1	4×0.65	29.6	85.2	390	90	135
	100	WTF 50100-3	52.2	44.1	2×1.65	36.3	108.1	500	90	135

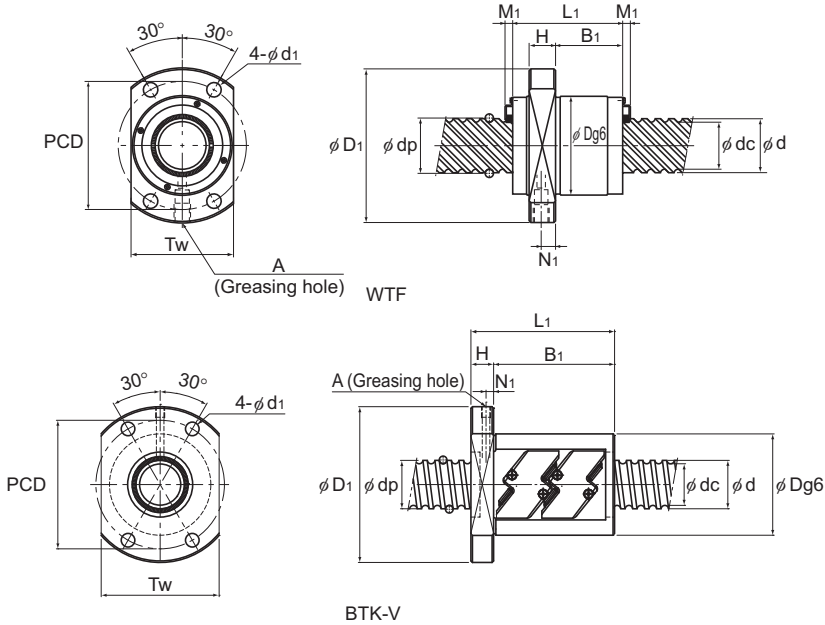

Unit: mm

Ball Screw

Nut dimensions										Axial clearance	Standard shaft length	Screw shaft inertial moment/mm ²	Nut mass	Shaft mass
Overall length	H	B ₁	PCD	d ₁	T _w	Greasing hole		Seal						
L ₁						N ₁	A	M ₁		kg·cm ² /mm	kg	kg/m		
68	15	53	85	9	78	5	M6	—	0.14	500, 1000, 2000, 2500	8.08 × 10 ⁻³	1.56	5.49	
98	15	83	85	9	78	5	M6	—	0.14		8.08 × 10 ⁻³	2.10	5.49	
70	15	45	74	9	68	7.5	M6	3.8	0.14	1000, 1500, 2000, 2500	8.08 × 10 ⁻³	1.14	5.69	
70	15	45	74	9	68	7.5	M6	3.8	0.14		8.08 × 10 ⁻³	1.14	5.69	
70	17	53	90	11	82	7	M6	—	0.17	500, 1000, 2000, 2500, 3000	1.29 × 10 ⁻²	1.78	6.91	
100	17	83	90	11	82	7	M6	—	0.17		1.29 × 10 ⁻²	2.35	6.91	
78	17	45	90	11	80	8.5	M6	5	0.17	1000, 1500, 2000, 3000	1.29 × 10 ⁻²	1.74	7.09	
94	18	59	94	11	86	9	M6	5	0.17		1.29 × 10 ⁻²	2.42	7.02	
77	17	50	85	11	76	8.5	M6	5	0.17		1.29 × 10 ⁻²	1.74	7.12	
77	17	50	85	11	76	8.5	M6	5	0.17		1.29 × 10 ⁻²	1.74	7.12	
100	17	83	96	11	88	7	M6	—	0.17	1000, 1500, 2000, 3000, 3500	1.97 × 10 ⁻²	2.60	8.81	
85	17	56.5	93	11	84	8.5	M6	5.4	0.17		1.97 × 10 ⁻²	2.16	8.76	
85	17	56.5	93	11	84	8.5	M6	5.4	0.17	1000, 1500, 2000, 3000	1.97 × 10 ⁻²	2.16	8.76	
79	17	50.5	93	11	74	8.5	M6	5.4	0.17		1.97 × 10 ⁻²	2.1	8.66	
159	17	130.5	93	11	74	8.5	M6	5.4	0.17		1.97 × 10 ⁻²	3.67	8.66	
118	20	98	104	14	94	8	M6	—	0.17	1000, 1500, 2000, 3000, 3500	3.16 × 10 ⁻²	3.48	11.08	
145	25	120	132	18	104	12.5	PT 1/8	—	0.2		4.82 × 10 ⁻²	6.52	13.66	
106	20	72	112	14	104	10	M6	5.4	0.2	1000, 1500, 2000, 3000	4.82 × 10 ⁻²	3.89	13.79	
106	20	72	112	14	104	10	M6	5.4	0.2		4.82 × 10 ⁻²	3.86	13.79	
98	20	64	112	14	92	10	M6	5.4	0.2		4.82 × 10 ⁻²	3.5	13.86	
198	20	164	112	14	92	10	M6	5.4	0.2		4.82 × 10 ⁻²	6.4	13.86	

No Preload Type of Rolled Ball Screw (Square Nut)

Screw shaft outer diameter	14 to 45
Lead	4 to 12

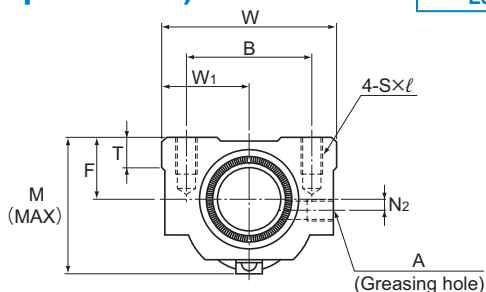

BNT

Screw shaft outer diameter d	Lead Ph	Model No.	Ball center-to-center diameter dp	Thread minor diameter dc	No. of loaded circuits Rows X turns	Basic load rating		Rigidity K			
						Ca kN	C _{0a} kN		Width W	Center height F	Overall length L ₁
14	4	BNT 1404-3.6	14.4	11.5	1×3.65	5.5	11.5	150	34	13	35
	5	BNT 1405-2.6	14.5	11.2	1×2.65	5	11.4	110	34	13	35
16	5	BNT 1605-2.6	16.75	13.5	1×2.65	5.4	13.3	130	42	16	36
18	8	BNT 1808-3.6	19.3	14.4	1×3.65	13.1	31	210	48	17	56
20	5	BNT 2005-2.6	20.5	17.2	1×2.65	6	16.5	150	48	17	35
	10	BNT 2010-2.6	21.25	16.4	1×2.65	10.6	25.1	160	48	18	58
25	5	BNT 2505-2.6	25.5	22.2	1×2.65	6.7	20.8	180	60	20	35
	10	BNT 2510-5.3	26.8	20.2	2×2.65	31.2	83.7	400	60	23	94
28	6	BNT 2806-2.6	28.5	25.2	1×2.65	7	23.4	200	60	22	42
		BNT 2806-5.3	28.5	25.2	2×2.65	12.8	46.8	390	60	22	67
32	10	BNT 3210-2.6	33.75	27.2	1×2.65	19.8	53.8	250	70	26	64
		BNT 3210-5.3	33.75	27.2	2×2.65	36	107.5	490	70	26	94
36	10	BNT 3610-2.6	37	30.5	1×2.65	20.8	59.3	270	86	29	64
		BNT 3610-5.3	37	30.5	2×2.65	37.8	118.7	530	86	29	96
45	12	BNT 4512-5.3	46.5	39.2	2×2.65	49.5	169	650	100	36	115

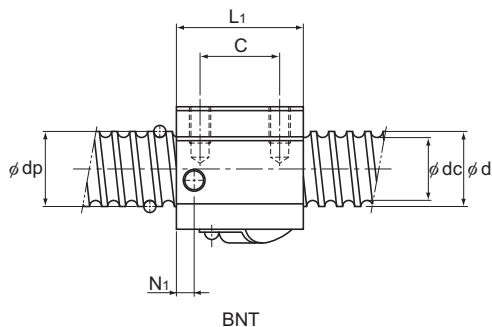

Unit: mm

Nut dimensions										Axial clearance	Screw shaft inertial moment/mm ⁴ kg·cm ² /mm	Nut mass kg	Shaft mass kg/m
Mounting hole			W _i	T	M	N ₁	N ₂	A					
B	C	S×ℓ											
26	22	M4×7	17	6	30	6	2	M6	0.1	2.96×10 ⁻⁴	0.15	1.0	
26	22	M4×7	17	6	31	6	2	M6	0.1	2.96×10 ⁻⁴	0.15	0.99	
32	22	M5×8	21	21.5	32.5	6	2	M6	0.1	5.05×10 ⁻⁴	0.3	1.34	
35	35	M6×10	24	10	44	8	3	M6	0.1	8.09×10 ⁻⁴	0.47	1.71	
35	22	M6×10	24	9	39	5	3	M6	0.1	1.23×10 ⁻³	0.28	2.15	
35	35	M6×10	24	9	46	10	2	M6	0.1	1.23×10 ⁻³	0.5	2.16	
40	22	M8×12	30	9.5	45	7	5	M6	0.1	3.01×10 ⁻³	0.41	3.45	
40	60	M8×12	30	10	55	10	—	M6	0.1	3.01×10 ⁻³	1.18	3.26	
40	18	M8×12	30	10	50	8	—	M6	0.1	4.74×10 ⁻³	0.81	4.44	
40	40	M8×12	30	10	50	8	—	M6	0.1	4.74×10 ⁻³	0.78	4.44	
50	45	M8×12	35	12	62	10	—	M6	0.14	8.08×10 ⁻³	1.3	5.49	
50	60	M8×12	35	12	62	10	—	M6	0.14	8.08×10 ⁻³	2.0	5.49	
60	45	M10×16	43	17	67	11	—	M6	0.17	1.29×10 ⁻²	1.8	6.91	
60	60	M10×16	43	17	67	11	—	M6	0.17	1.29×10 ⁻²	2.4	6.91	
75	75	M12×20	50	20.5	80	13	—	M6	0.2	3.16×10 ⁻²	4.1	11.08	

Model Number Coding

Model number coding

Ball Screw Nut

BTK1405V-2.6 ZZ

Model number

Seal symbol

no symbol: without seal

ZZ: brush seal attached to both ends of the ball screw nut (see [A15-352](#))

Screw Shaft

TS 14 05 +500L C7

Accuracy symbol (see [A15-12](#)) (no symbol for class C10)

Overall screw shaft length (in mm)

Lead (in mm)

Screw shaft outer diameter (in mm)

Symbol for rolled ball screw shaft

Combination of the Ball Screw Nut and the Screw Shaft

BTK1405V-2.6 ZZ +500L C7 T

Model number

Symbol for rolled shaft

Accuracy symbol (see [A15-12](#)) (no symbol for class C10)

Overall screw shaft length (in mm)

Seal symbol

no symbol: without seal

ZZ: brush seal attached to both ends of the ball screw nut (see [A15-352](#))

Rolled Ball Screw model JPF

JPF1404-4 RR G0 +500L C7 T

Model number

Symbol for rolled shaft

Accuracy symbol (see [A15-12](#)) (no symbol for class C10)

Overall screw shaft length (in mm)

Axial clearance symbol

Seal symbol

no symbol: without seal

RR: Labyrinth seal attached to both ends of the ball screw nut (see [A15-352](#))

