

RSR

LM Guide Miniature Types Model RSR

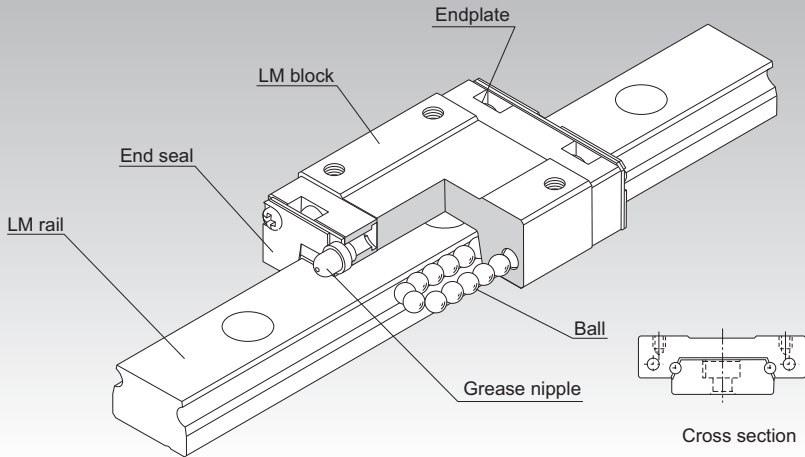

Point of Selection	A1-10
Point of Design	A1-436
Options	A1-459
Model No.	A1-524
Precautions on Use	A1-530
Accessories for Lubrication	A24-1
Mounting Procedure and Maintenance	B1-89
Equivalent moment factor	A1-43
Rated Loads in All Directions	A1-58
Equivalent factor in each direction	A1-60
Radial Clearance	A1-71
Accuracy Standards	A1-82
Shoulder Height of the Mounting Base and the Corner Radius	A1-451
Permissible Error of the Mounting Surface	A1-453
Flatness of the Mounting Surface	A1-454
Dimensions of Each Model with an Option Attached	A1-472

Structure and Features

With models RSR and RSR-W, balls roll in two rows of raceways precision-ground on an LM rail and an LM block, and endplates incorporated in the LM block allow the balls to circulate. Since balls circulate in a compact structure, the LM Block is able to provide infinite straight motion and thus infinite stroke.

The LM block is designed to have a shape with high rigidity in a limited space, and in combination with large-diameter balls, demonstrates high rigidity in all directions.

[Ultra Compact]

The absence of cage displacement, a problem that cross-roller guides and types of ball slides with finite stroke tend to cause, make these models highly reliable LM systems.

[Capable of Receiving Loads in All Directions]

These models are capable of receiving loads in all directions, and a single-rail guide can adequately operate under a small moment load. Model RSR-W, in particular, has a greater number of effective balls and a broader LM rail to increase its rigidity against a moment. Thus, it achieves a more compact structure and more durable straight motion than a pair of linear bushes in parallel use.

[Stainless Steel Type also Available]

A special type where LM block, LM rail and balls are made of stainless steel is also available.

Types and Features

Model RSR-M

Specification Table⇒ **A1-254**

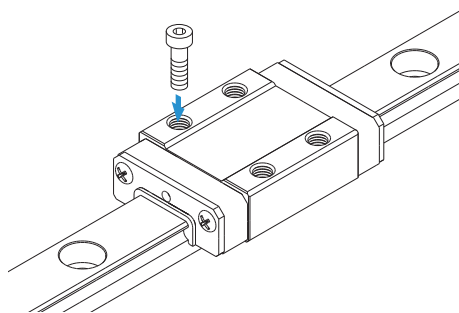

Models RSR-WM/WVM

These models have greater overall LM block lengths (L), broader widths (W) and greater rated loads and permissible moments than standard types.

Specification Table⇒ **A1-254**

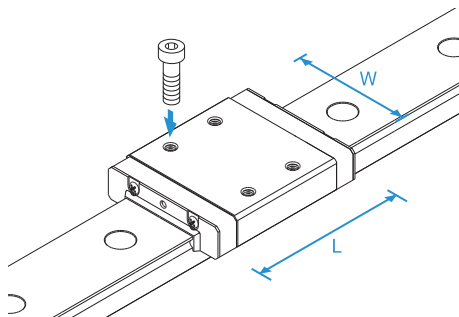

Model RSR-N

It has a longer overall LM block length (L) and a greater rated load than standard types.

Specification Table⇒ **A1-254**

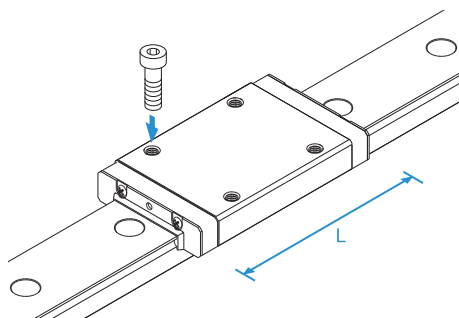

Model RSR-WN

It has a longer overall LM block length (L), a greater rated load than standard types. Achieves the greatest load capacity among the miniature type LM Guide models.

Specification Table → **A1-254**

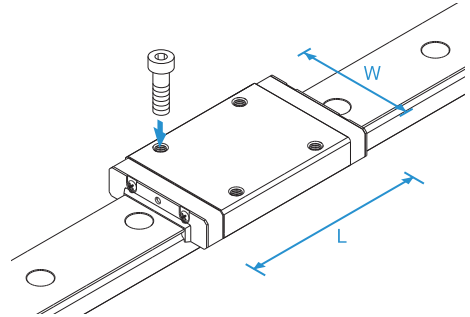

LM Guide

Accuracy of the Mounting Surface

Model RSR uses Gothic arch grooves in the ball raceways. When two rails of RSR are used in parallel, any error in accuracy of the mounting surface may increase rolling resistance and negatively affect the smooth motion of the guide. For specific accuracy of the mounting surface, see [Flatness of the Mounting Surface] on **A1-454**.

Models RSR-M, RSR-N, RSR-WM, RSR-WN and RSR-WVM

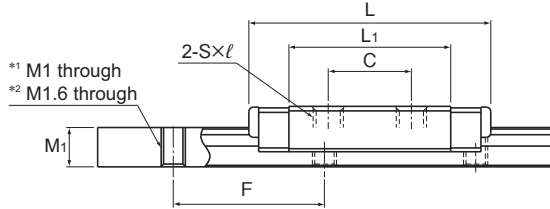
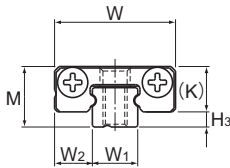

Models RSR2N, RSR3N

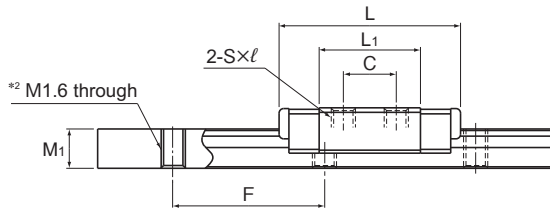
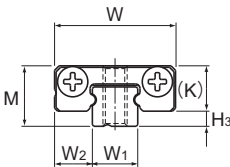

Model RSR3M

Model No.	Outer dimensions			LM block dimensions										Grease nipple	H ₃
	Height	Width	Length	B	C	S × l	L ₁	T	K	N	E	d			
	M	W	L												
RSR 2N RSR 2WN	3.2 4	6 10	12.4 16.7	—	4 6.5	M1.4 × 1.1 M2 × 1.3	8.84 11.9	—	2.5 3	—	—	—	—	0.7 1	
RSR 3M RSR 3N	4	8	12 16	—	3.5 5.5	M1.6 × 1.3 M2 × 1.3	6.7 10.7	—	3	—	—	—	—	1	
RSR 3WM RSR 3WN	4.5	12	14.9 19.9	—	4.5 8	M2 × 1.7	8.5 13.3	—	3.5	0.8	—	0.8	—	1	
RSR 14WVM	15	50	50	35	18	M4 × 4.5	34.3	6	11.5	3	4	—	PB107	3.5	

Note) Since stainless steel is used in the LM block, LM rail and balls, these models are highly resistant to corrosion and environment. Models RSR2 and 3 do not have an oil hole. When lubricating them, apply a lubricant directly to the LM rail raceways. No contamination protection seal for RSR2N/2WN/3M/3N.

Model number coding

2	RSR3	M	UU	C1	+80L	P	M	-II
Model number	Contamination protection accessory symbol (*1)		LM rail length (in mm)	Stainless steel LM rail	Symbol for No. of rails used on the same plane (*4)			
No. of LM blocks used on the same rail	Radial clearance symbol (*2) Normal (No symbol) Light preload (C1)		Accuracy symbol (*3) Normal grade (No Symbol)/Precision grade (P)					

(*1) See contamination protection accessory on **A1-496**. (*2) See **A1-71**. (*3) See **A1-82**. (*4) See **A1-13**.

Note) This model number indicates that a single-rail unit constitutes one set. (i.e., required number of sets when 2 rails are used in parallel is 2 at a minimum.)

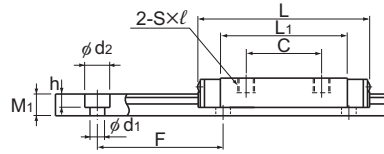
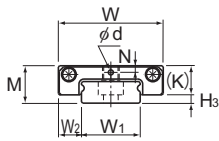

Models RSR2WN, RSR3WM/WN

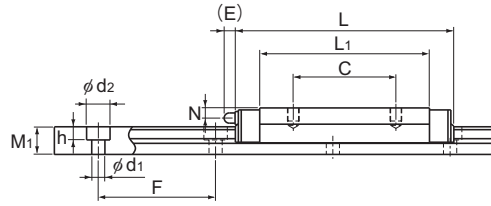
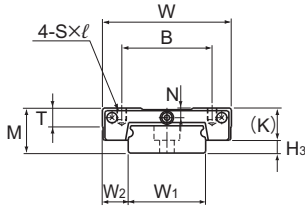

Model RSR14WVM

Unit: mm

LM rail dimensions						Basic load rating		Static permissible moment N-m*						Mass	
Width		Height		Pitch	Length*	C	C ₀	M _A		M _B		M _C	LM block kg	LM rail kg/m	
W ₁	W ₂	M ₁	F	d ₁ × d ₂ × h				1 block	Double blocks	1 block	Double blocks	1 block			
2	0	2	2	8	1.8 × 2.8 × 0.75	200	0.214	0.384	0.564	2.994	0.564	2.994	0.442	0.0008	0.0029
4	-0.03	3	2.6	10		0.395	0.682	1.336	7.32	1.336	7.32	1.501	0.0020	0.0075	
3	0	2.5	2.6	10	— ²	220	0.18	0.27	0.293	2.11	0.293	2.11	0.45	0.0011	0.055
	-0.02					0.3	0.44	0.726	4.33	0.726	4.33	0.73	0.0016		
6	0	3	2.6	15	2.4 × 4 × 1.5	480	0.25	0.47	0.668	4.44	0.668	4.44	1.48	0.002	0.12
	-0.02					0.39	0.75	1.57	9.06	1.57	90.6	2.36	0.003		
30	0	10	9	40	4.5 × 7.5 × 5.3	1800	6.01	9.08	43.2	233	38.2	208	110	0.096	2
	-0.05														

Note) The maximum length under "Length*" indicates the standard maximum length of an LM rail. (See **A1-256**.)

Static permissible moment*: 1 block: static permissible moment value with 1 LM block

Double blocks: static permissible moment value with 2 blocks closely contacting with each other

- Recommended tightening torque when mounting the LM rail/block

Table1 shows recommended bolt tightening torques when mounting the LM block and LM rail of models RSR2 and RSR3.

Table1 Recommended Tightening Torques of Mounting Bolts

Model No.	Model No. of screw	Recommended tightening torque (N-m)		Remarks
		Block	Rail	
RSR 2N	M1	0.09	0.03	Flathead machine screw designed for use with precision equipment
RSR 2WN	M1.6	0.28	0.138	
RSR 3M	M1.6	0.09	0.09	Austenite stainless steel hexagonal-socket-head type bolts
RSR 3N	M2	0.19	0.19	

Standard Length and Maximum Length of the LM Rail

Table2 shows the standard and maximum lengths of the RSR model rail.

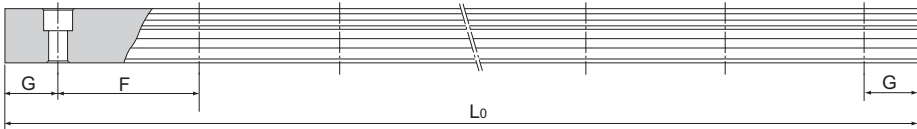

Table2 Standard Length and Maximum Length of the LM Rail for Model RSR/RSR-W

Unit: mm

Model No.	RSR2N	RSR2WN	RSR3	RSR3W	RSR14W
LM rail standard length (L ₀)	32	40	30	40	110
	40	60	40	55	150
	56	70	60	70	190
	80	80	80		230
	104	100	100		270
		180			310
Standard pitch F	8	10	10	15	40
G	4	5	5	5	15
Max length	200	200	220	480	1800

Note1) The maximum length varies with accuracy grades. Contact THK for details.

Note2) The LM rail mounting hole of model RSR3 is an M1.6 through hole.

Stopper

In model RSR/RSR-W, the balls fall out if the LM block comes off the LM rail.

For this reason, they are delivered with a stopper fitted to prevent the LM block coming off the rail. If you remove the stopper when using the product, take care to ensure that overrun does not occur.

Table3 Model RSR/RSR-W stopper (C type)
specification table

Unit: mm

Model No.	A	B	C
14W	33.8	7	13

Note) Models RSR2 and RSR3 use O-rings.

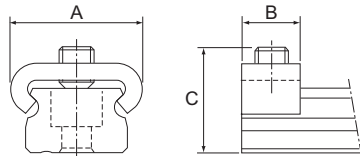

Fig.1 Model RSR/RSR-W stopper (C type)

