

HSR-M1

LM Guide High Temperature Type Model HSR-M1

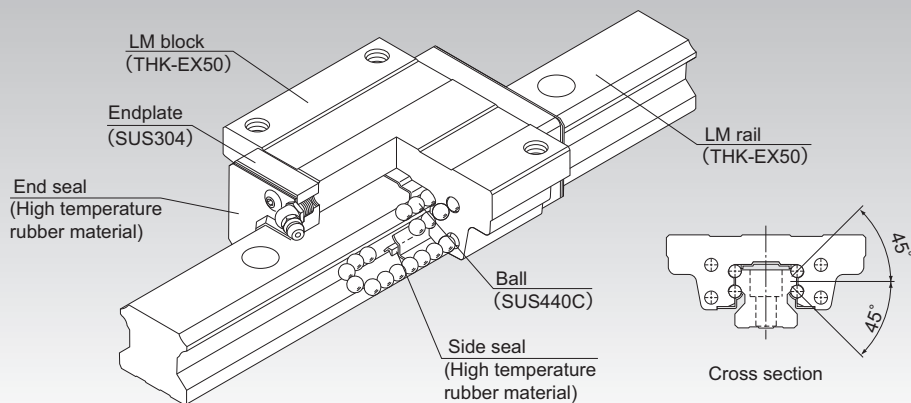

Point of Selection **A1-10**

Point of Design **A1-436**

Options **A1-459**

Model No. **A1-524**

Precautions on Use **A1-530**

Accessories for Lubrication **A24-1**

Mounting Procedure and Maintenance **B1-89**

Equivalent moment factor **A1-43**

Rated Loads in All Directions **A1-58**

Equivalent factor in each direction **A1-60**

Radial Clearance **A1-71**

Accuracy Standards **A1-76**

Shoulder Height of the Mounting Base and the Corner Radius **A1-447**

Permissible Error of the Mounting Surface **A1-452**

Dimensions of Each Model with an Option Attached **A1-472**

Structure and Features

Balls roll in four rows of raceways precision-ground on an LM rail and an LM block, and endplates incorporated in the LM block allow the balls to circulate.

Each row of balls is placed at a contact angle of 45° so that the rated loads applied to the LM block are uniform in the four directions (radial, reverse radial and lateral directions), enabling the LM Guide to be used in all orientations.

The high temperature type LM Guide is capable of being used at service temperature up to 150°C thanks to THK's unique technologies in material, heat treatment and lubrication.

[Maximum Service Temperature: 150°C]

Use of stainless steel in the endplates and high temperature rubber in the end seals achieves the maximum service temperature of 150°C.

[Dimensional Stability]

Since it is dimensionally stabilized, it demonstrates superb dimensional stability after being heated or cooled (note that it shows linear expansion at high temperature).

[Highly Corrosion Resistant]

Since the LM block, LM rail and balls use stainless steel, which is highly corrosion resistant, this model is optimal for clean room applications.

[High Temperature Grease]

This model uses high temperature grease that shows little grease-based fluctuation in rolling resistance even if temperature changes from low to high levels.

● Dimensional Stability Data

Since this model has been treated for dimensional stability, its dimensional change after being cooled or heated is only minimal.

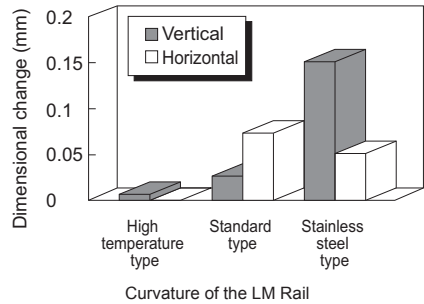
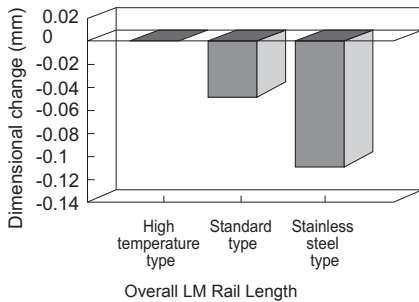

Note1) The above data on overall length and curvature indicate dimensional change when the LM rail is cooled to normal temperature after being heated at 150°C for 100 hours.

Note2) The samples consist of high temperature, standard and stainless steel types of model HSR25 + 580L.

● Rolling Resistance Data in Relation to Grease

Use a high temperature grease with which the rolling resistance of the LM system little fluctuates even temperature changes from a normal to high range.

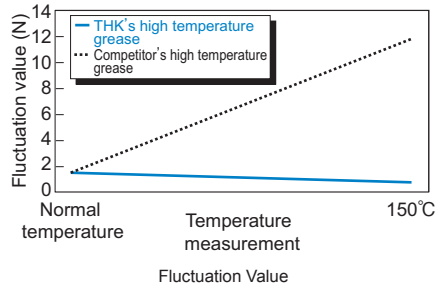
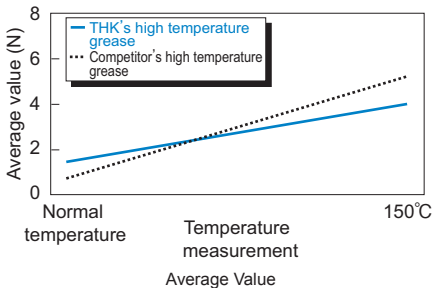

For the measurements above, model HSR25M1R1C1 is used.

● Thermal Characteristics of LM Rail and LM Block Materials

Specific heat capacity: 0.481 J/(g·K)

Thermal conductivity: 20.67 W/(m·K)

Average coefficient of linear expansion: $11.8 \times 10^{-6}/^{\circ}\text{C}$

Types and Features

Model HSR-M1A

The flange of its LM block has tapped holes.

Specification Table⇒ **A1-342**

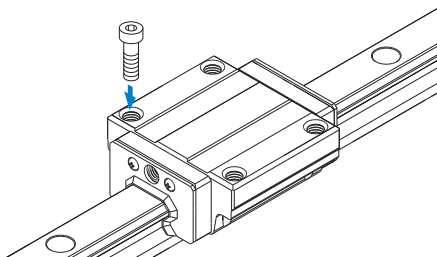

Model HSR-M1LA

The LM block has the same cross-sectional shape as model HSR-M1A, but has a longer overall LM block length (L) and a greater rated load.

Specification Table⇒ **A1-342**

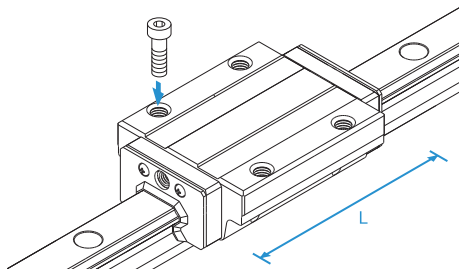

Model HSR-M1B

The flange of the LM block has through holes. Used in places where the table cannot have through holes for mounting bolts.

Specification Table⇒ **A1-344**

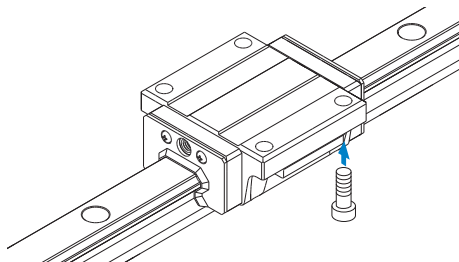

Model HSR-M1LB

The LM block has the same sectional shape as model HSR-M1B, but has a longer overall LM block length (L) and a greater rated load.

Specification Table⇒ **A1-344**

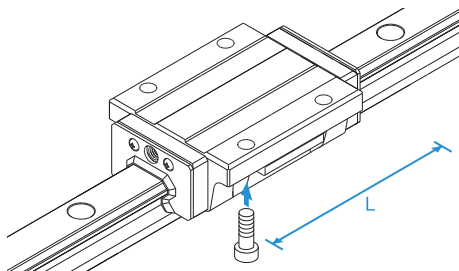

Model HSR-M1R

With this type, the LM block has a smaller width (W) and tapped holes. Used in places where the space for table width is limited.

Specification Table⇒**A1-346**

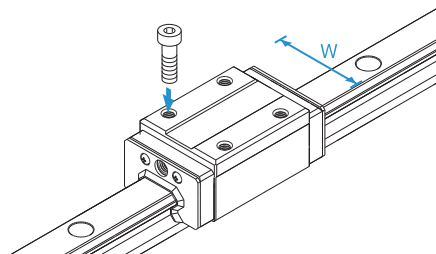

Model HSR-M1LR

The LM block has the same sectional shape as model HSR-M1R, but has a longer overall LM block length (L) and a greater rated load.

Specification Table⇒**A1-346**

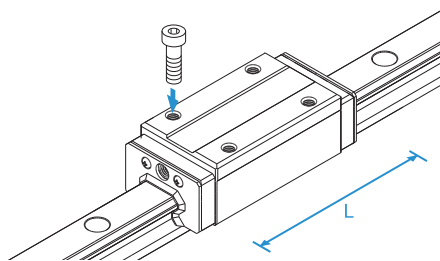

Model HSR-M1YR

When using two units of LM Guide facing each other, the previous model required much time in machining the table and had difficulty achieving the desired accuracy and adjusting the clearance. Since model HSR-M1YR has tapped holes on the side of the LM block, a simpler structure is gained and significant man-hour cutting and accuracy increase can be achieved.

Specification Table⇒**A1-348**

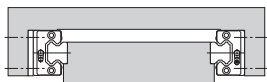
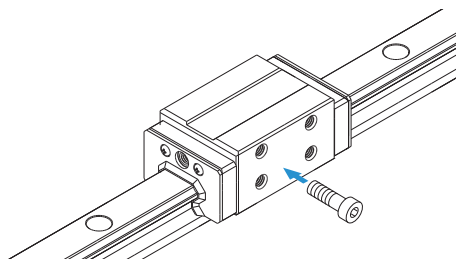

Fig.1 Conventional Structure

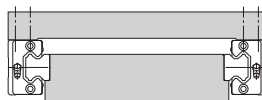
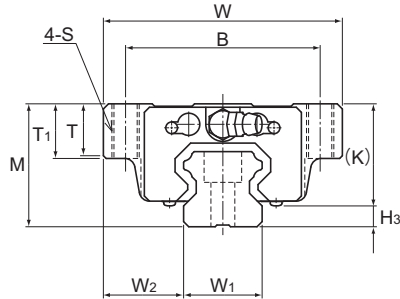

Fig.2 Mounting Structure for Model HSR-M1YR

Service Life

When using this product in temperatures higher than 100°C, always multiply the basic dynamic load rating by the temperature coefficient when calculating the rated service life. See **A1-64** for details.

Models HSR-M1A and HSR-M1LA



Model No.	Outer dimensions			LM block dimensions										Grease nipple	H ₃
	Height	Width	Length	B	C	S	L ₁	T	T ₁	K	N	E			
	M	W	L	B	C	S	L ₁	T	T ₁	K	N	E			
HSR 15M1A	24	47	59.6	38	30	M5	38.8	6.5	11	19.3	4.3	5.5	PB1021B	4.7	
HSR 20M1A HSR 20M1LA	30	63	76 92	53	40	M6	50.8 66.8	9.5	10	26	5	12	B-M6F	4	
HSR 25M1A HSR 25M1LA	36	70	83.9 103	57	45	M8	59.5 78.6	11	16	30.5	6	12	B-M6F	5.5	
HSR 30M1A HSR 30M1LA	42	90	98.8 121.4	72	52	M10	70.4 93	9	18	35	7	12	B-M6F	7	
HSR 35M1A HSR 35M1LA	48	100	112 137.4	82	62	M10	80.4 105.8	12	21	40.5	8	12	B-M6F	7.5	

Note) The length L of the high temperature type LM Guide model HSR is longer than normal type of model HSR. (Dimension L₁ is the same.)

Model number coding

HSR25 M1 A 2 UU C1 +1240L P T -II

Model number

Type of LM block

Contamination protection accessory symbol (*1)

LM rail length (in mm)

Symbol for LM rail jointed use

Symbol for No. of rails used on the same plane (*4)

Symbol for high temperature type LM Guide

No. of LM blocks used on the same rail

Radial clearance symbol (*2)
Normal (No symbol)
Light preload (C1)
Medium preload (C0)

Accuracy symbol (*3)
Normal grade (No Symbol)/High accuracy grade (H)
Precision grade (P)/Super precision grade (SP)
Ultra precision grade (UP)

(*1) See contamination protection accessory on **A1-496**. (*2) See **A1-71**. (*3) See **A1-76**. (*4) See **A1-13**.

Note) This model number indicates that a single-rail unit constitutes one set. (i.e., required number of sets when 2 rails are used in parallel is 2 at a minimum.)

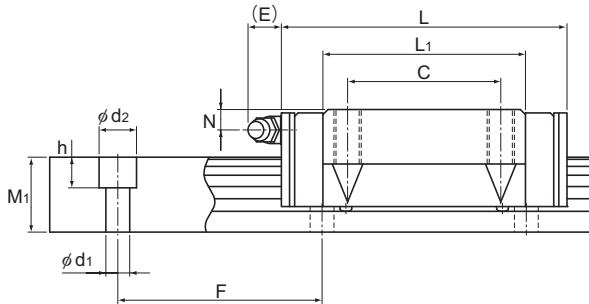

Unit: mm

LM rail dimensions						Basic load rating		Static permissible moment kN-m*					Mass	
Width W_1 ± 0.05	W_2	Height M_1	Pitch F	Length* $d_1 \times d_2 \times h$ Max	C kN	C_0 kN	M_A		M_B		M_C	LM block kg	LM rail kg/m	
							1 block	Double blocks	1 block	Double blocks	1 block			
15	16	15	60	4.5×7.5×5.3	1240	8.33	13.5	0.0805	0.457	0.0805	0.457	0.0844	0.2	1.5
20	21.5	18	60	6×9.5×8.5	1480	13.8 21.3	23.8 31.8	0.19 0.323	1.04 1.66	0.19 0.323	1.04 1.66	0.201 0.27	0.35 0.47	2.3
23	23.5	22	60	7×11×9	1500	19.9 27.2	34.4 45.9	0.307 0.529	1.71 2.74	0.307 0.529	1.71 2.74	0.344 0.459	0.59 0.75	3.3
28	31	26	80	9×14×12	1500	28 37.3	46.8 62.5	0.524 0.889	2.7 4.37	0.524 0.889	2.7 4.37	0.562 0.751	1.1 1.3	4.8
34	33	29	80	9×14×12	1500	37.3 50.2	61.1 81.5	0.782 1.32	3.93 6.35	0.782 1.32	3.93 6.35	0.905 1.2	1.6 2	6.6

Note) The maximum length under "Length*" indicates the standard maximum length of an LM rail. (See **A1-350**.)

Static permissible moment*: 1 block: static permissible moment value with 1 LM block

Double blocks: static permissible moment value with 2 blocks closely contacting with each other

Models HSR-M1B and HSR-M1LB

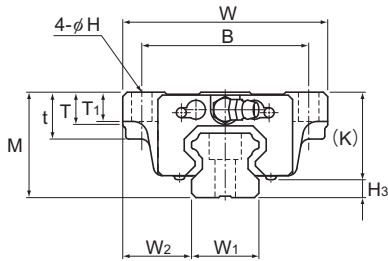

Models HSR15, 25 to 35M1B/M1LB

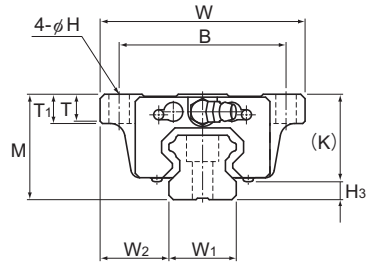

Models HSR20M1B/M1LB

Model No.	Outer dimensions			LM block dimensions											Grease nipple	H ₃
	Height	Width	Length	B	C	H	L ₁	t	T	T ₁	K	N	E			
	M	W	L													
HSR 15M1B	24	47	59.6	38	30	4.5	38.8	11	6.5	7	19.3	4.3	5.5	PB1021B	4.7	
HSR 20M1B HSR 20M1LB	30	63	76 92	53	40	6	50.8 66.8	—	9.5	10	26	5	12	B-M6F	4	
HSR 25M1B HSR 25M1LB	36	70	83.9 103	57	45	7	59.5 78.6	16	11	10	30.5	6	12	B-M6F	5.5	
HSR 30M1B HSR 30M1LB	42	90	98.8 121.4	72	52	9	70.4 93	18	9	10	35	7	12	B-M6F	7	
HSR 35M1B HSR 35M1LB	48	100	112 137.4	82	62	9	80.4 105.8	21	12	13	40.5	8	12	B-M6F	7.5	

Note) The length L of the high temperature type LM Guide model HSR is longer than normal type of model HSR. (Dimension L₁ is the same.)

Model number coding

HSR20 M1 LB 2 UU C0 +1000L P T - II

Model number

Type of LM block

Contamination protection accessory symbol (*1)

LM rail length (in mm)

Symbol for LM rail jointed use

Symbol for No. of rails used on the same plane (*4)

Symbol for high temperature type LM Guide

No. of LM blocks used on the same rail

Radial clearance symbol (*2)
Normal (No symbol)
Light preload (C1)
Medium preload (C0)

Accuracy symbol (*3)

Normal grade (No Symbol)/High accuracy grade (H)
Precision grade (P)/Super precision grade (SP)
Ultra precision grade (UP)

(*1) See contamination protection accessory on **A1-496**. (*2) See **A1-71**. (*3) See **A1-76**. (*4) See **A1-13**.

Note) This model number indicates that a single-rail unit constitutes one set. (i.e., required number of sets when 2 rails are used in parallel is 2 at a minimum.)

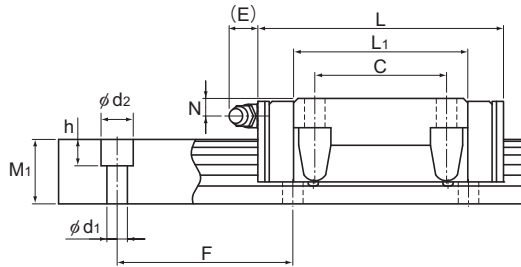

Unit: mm

LM rail dimensions						Basic load rating		Static permissible moment kN-m*					Mass	
Width	Height	Pitch		Length*	C	C ₀	M _A		M _B		M _C	LM block	LM rail	
W ₁ ±0.05	W ₂	M ₁	F	d ₁ × d ₂ × h	Max	kN	kN	1 block	Double blocks	1 block	Double blocks	1 block	kg	kg/m
15	16	15	60	4.5 × 7.5 × 5.3	1240	8.33	13.5	0.0805	0.457	0.0805	0.457	0.0844	0.2	1.5
20	21.5	18	60	6 × 9.5 × 8.5	1480	13.8 21.3	23.8 31.8	0.19 0.323	1.04 1.66	0.19 0.323	1.04 1.66	0.201 0.27	0.35 0.47	2.3
23	23.5	22	60	7 × 11 × 9	1500	19.9 27.2	34.4 45.9	0.307 0.529	1.71 2.74	0.307 0.529	1.71 2.74	0.344 0.459	0.59 0.75	3.3
28	31	26	80	9 × 14 × 12	1500	28 37.3	46.8 62.5	0.524 0.889	2.7 4.37	0.524 0.889	2.7 4.37	0.562 0.751	1.1 1.3	4.8
34	33	29	80	9 × 14 × 12	1500	37.3 50.2	61.1 81.5	0.782 1.32	3.93 6.35	0.782 1.32	3.93 6.35	0.905 1.2	1.6 2	6.6

Note) The maximum length under "Length*" indicates the standard maximum length of an LM rail. (See **A1-350**.)

Static permissible moment*: 1 block: static permissible moment value with 1 LM block

Double blocks: static permissible moment value with 2 blocks closely contacting with each other

Models HSR-M1R and HSR-M1LR

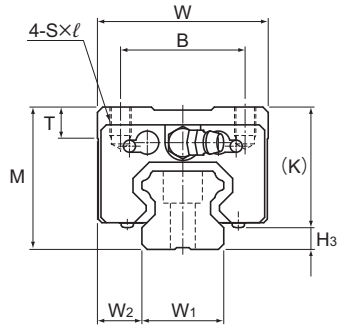

Model No.	Outer dimensions			LM block dimensions									H ₃
	Height	Width	Length	B	C	S×ℓ	L ₁	T	K	N	E	Grease nipple	
	M	W	L										
HSR 15M1R	28	34	59.6	26	26	M4×5	38.8	6	23.3	8.3	5.5	PB1021B	4.7
HSR 20M1R HSR 20M1LR	30	44	76 92	32	36 50	M5×6	50.8 66.8	8	26	5	12	B-M6F	4
HSR 25M1R HSR 25M1LR	40	48	83.9 103	35	35 50	M6×8	59.5 78.6	8	34.5	10	12	B-M6F	5.5
HSR 30M1R HSR 30M1LR	45	60	98.8 121.4	40	40 60	M8×10	70.4 93	8	38	10	12	B-M6F	7
HSR 35M1R HSR 35M1LR	55	70	112 137.4	50	50 72	M8×12	80.4 105.8	10	47.5	15	12	B-M6F	7.5

Note) The length L of the high temperature type LM Guide model HSR is longer than normal type of model HSR. (Dimension L₁ is the same.)

Model number coding

HSR35 M1 R 2 UU C0 +1080L P T -II

Model number

Type of LM block

Contamination protection accessory symbol (*1)

LM rail length (in mm)

Symbol for LM rail jointed use

Symbol for No. of rails used on the same plane (*4)

Symbol for high temperature type LM Guide

No. of LM blocks used on the same rail

Radial clearance symbol (*2)
Normal (No symbol)
Light preload (C1)
Medium preload (C0)

Accuracy symbol (*3)
Normal grade (No Symbol)/High accuracy grade (H)
Precision grade (P)/Super precision grade (SP)
Ultra precision grade (UP)

(*1) See contamination protection accessory on **A1-496**. (*2) See **A1-71**. (*3) See **A1-76**. (*4) See **A1-13**.

Note) This model number indicates that a single-rail unit constitutes one set. (i.e., required number of sets when 2 rails are used in parallel is 2 at a minimum.)

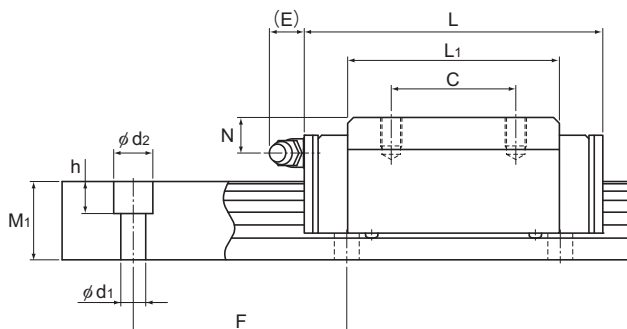

Unit: mm

LM rail dimensions						Basic load rating		Static permissible moment kN-m*					Mass	
Width W_1 ± 0.05	Height M_1	Pitch F	Length* Max	$d_1 \times d_2 \times h$	C	C_0	M_A		M_B		M_C	LM block kg	LM rail kg/m	
							1 block	Double blocks	1 block	Double blocks	1 block			
15	9.5	15	60	4.5 × 7.5 × 5.3	1240	8.33	13.5	0.0805	0.457	0.0805	0.457	0.0844	0.2	1.5
20	12	18	60	6 × 9.5 × 8.5	1480	13.8 21.3	23.8 31.8	0.19 0.323	1.04 1.66	0.19 0.323	1.04 1.66	0.201 0.27	0.35 0.47	2.3
23	12.5	22	60	7 × 11 × 9	1500	19.9 27.2	34.4 45.9	0.307 0.529	1.71 2.74	0.307 0.529	1.71 2.74	0.344 0.459	0.59 0.75	3.3
28	16	26	80	9 × 14 × 12	1500	28 37.3	46.8 62.5	0.524 0.889	2.7 4.37	0.524 0.889	2.7 4.37	0.562 0.751	1.1 1.3	4.8
34	18	29	80	9 × 14 × 12	1500	37.3 50.2	61.1 81.5	0.782 1.32	3.93 6.35	0.782 1.32	3.93 6.35	0.905 1.2	1.6 2	6.6

Note) The maximum length under "Length*" indicates the standard maximum length of an LM rail. (See **A1-350**.)

Static permissible moment*: 1 block: static permissible moment value with 1 LM block

Double blocks: static permissible moment value with 2 blocks closely contacting with each other

Model HSR-M1YR

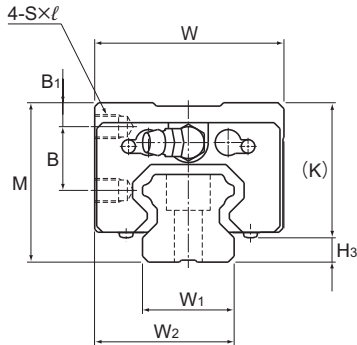

Model No.	Outer dimensions			LM block dimensions									Grease nipple	H ₃
	Height	Width	Length	B ₁	B	C	S×ℓ	L ₁	K	N	E			
	M	W	L											
HSR 15M1YR	28	33.5	59.6	4.3	11.5	18	M4×5	38.8	23.3	8.3	5.5	PB1021B	4.7	
HSR 20M1YR	30	43.5	76	4	11.5	25	M5×6	50.8	26	5	12	B-M6F	4	
HSR 25M1YR	40	47.5	83.9	6	16	30	M6×6	59.5	34.5	10	12	B-M6F	5.5	
HSR 30M1YR	45	59.5	98.8	8	16	40	M6×9	70.4	38	10	12	B-M6F	7	
HSR 35M1YR	55	69.5	112	8	23	43	M8×10	80.4	47.5	15	12	B-M6F	7.5	

Note) The length L of the high temperature type LM Guide model HSR-YR is longer than normal type of model HSR-YR. (Dimension L₁ is the same.)

Model number coding

HSR25 M1 YR 2 UU C0 +1200L P T -II

Model number

Type of LM block

Contamination protection accessory symbol (*1)

LM rail length (in mm)

Symbol for LM rail jointed use

Symbol for No. of rails used on the same plane (*4)

Symbol for high temperature type LM Guide

No. of LM blocks used on the same rail

Radial clearance symbol (*2)
Normal (No symbol)
Light preload (C1)
Medium preload (C0)

Accuracy symbol (*3)
Normal grade (No Symbol)/High accuracy grade (H)
Precision grade (P)/Super precision grade (SP)
Ultra precision grade (UP)

(*1) See contamination protection accessory on **A1-496**. (*2) See **A1-71**. (*3) See **A1-76**. (*4) See **A1-13**.

Note) This model number indicates that a single-rail unit constitutes one set. (i.e., required number of sets when 2 rails are used in parallel is 2 at a minimum.)

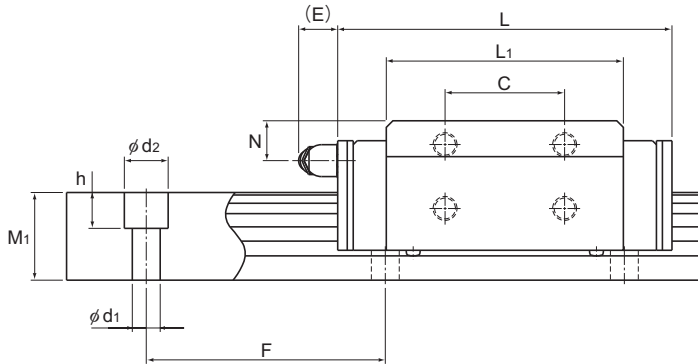

Unit: mm

	LM rail dimensions					Basic load rating			Static permissible moment kN-m*					Mass	
	Width	Height	Pitch	Length*	C	C ₀	M _A		M _B		M _C	LM block	LM rail		
	W ₁ ±0.05						W ₂	Max	kN	kN	1 block			Double blocks	1 block
	15	24	15	60	4.5×7.5×5.3	1240	8.33	13.5	0.0805	0.457	0.0805	0.457	0.0844	0.2	1.5
	20	31.5	18	60	6×9.5×8.5	1480	13.8	23.8	0.19	1.04	0.19	1.04	0.201	0.35	2.3
	23	35	22	60	7×11×9	1500	19.9	34.4	0.307	1.71	0.307	1.71	0.344	0.59	3.3
	28	43.5	26	80	9×14×12	1500	37.3	62.5	0.524	2.7	0.524	2.7	0.562	1.3	4.8
	34	51.5	29	80	9×14×12	1500	37.3	61.1	0.782	3.93	0.782	3.93	0.905	1.6	6.6

Note) The maximum length under "Length*" indicates the standard maximum length of an LM rail. (See **A1-350**.)

Static permissible moment*: 1 block: static permissible moment value with 1 LM block

Double blocks: static permissible moment value with 2 blocks closely contacting with each other

Standard Length and Maximum Length of the LM Rail

Table1 shows the standard lengths and the maximum lengths of model HSR-M1 variations. If the maximum length of the desired LM rail exceeds them, jointed rails will be used. Contact THK for details.

For the G dimension when a special length is required, we recommend selecting the corresponding G value from the table. The longer the G dimension is, the less stable the G area may become after installation, thus causing an adverse impact to accuracy.

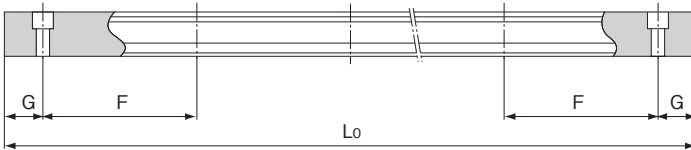

Table1 Standard Length and Maximum Length of the LM Rail for Model HSR-M1

Unit: mm

Model No.	HSR 15M1	HSR 20M1	HSR 25M1	HSR 30M1	HSR 35M1
LM rail standard length (L_0)	160	220	220	280	280
	220	280	280	360	360
	280	340	340	440	440
	340	400	400	520	520
	400	460	460	600	600
	460	520	520	680	680
	520	580	580	760	760
	580	640	640	840	840
	640	700	700	920	920
	700	760	760	1000	1000
	760	820	820	1080	1080
	820	940	940	1160	1160
	940	1000	1000	1240	1240
	1000	1060	1060	1320	1320
	1060	1120	1120	1400	1400
	1120	1180	1180	1480	1480
1180	1240	1240			
1240	1360	1300			
	1480	1360			
		1420			
		1480			
Standard pitch F	60	60	60	80	80
G	20	20	20	20	20
Max length	1240	1480	1500	1500	1500

Note1) The maximum length varies with accuracy grades. Contact THK for details.

Note2) If jointed rails are not allowed and a greater length than the maximum values above is required, contact THK.

Note3) The values for HSR-M1 also apply to HSR-M1YR.

