

**SM**

# SM6 SERIES

3/16" DIAMETER CABLE

## Design Data Sheet

Square Mount Isolator

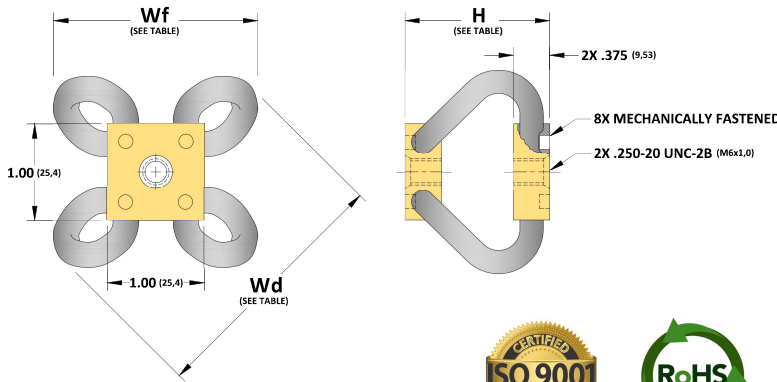

### NOTES, FEATURES, MATERIALS/FINISHES

#### NOTES:

- ALL DIMENSIONS IN PARENTHESIS ARE METRIC (mm)
- SPECIALS AVAILABLE UPON REQUEST (MATERIALS, SIZE, MOUNTING HOLES, FINISH, ETC...)
- ADD 'M' TO END OF PART NUMBER FOR METRIC INSERTS

#### FEATURES:

- RUGGED ALL METAL CONSTRUCTION
- UNEQUALLED TEMP. RANGE: -200°F TO 500°F
- THREE AXIS CAPABILITY (6 DOF)
- HIGH DAMPING: C/Cc ≈ .15-.20
- LONG LIFE AND MAINTENANCE FREE

#### MATERIALS/FINISHES:

- CABLE: 300 SERIES SS PER MIL-W-83420 OR RR-W-410
- INSERTS: 300 SERIES SS PER MS122081
- RETAINER BARS: 6063-T52 ALUMINUM ALLOY/CHEM FILM IAW MIL-C-5541, CLASS 1A

PART NUMBER	DIMENSIONS in (mm)			ISOLATOR WEIGHT oz (gms)	COMPRESSION		ROLL		COMPRESSION/ROLL	
	H ±.03	Wf (REF)	Wd (REF)		Kv (VIBE) (lbs/in)	Ks (SHOCK) (lbs/in)	Kv (VIBE) (lbs/in)	Ks (SHOCK) (lbs/in)	Kv (VIBE) (lbs/in)	Ks (SHOCK) (lbs/in)
SM6-165-A	1.65 (41.9)	2.25 (57.2)	2.98 (75.7)	2.00 (56.8)	75	52	34	39	48	32
SM6-185-A	1.85 (47.0)	2.55 (64.8)	3.25 (82.6)	2.20 (62.4)	42	31	21	24	32	19
SM6-215-A	2.15 (54.6)	2.76 (70.1)	3.60 (91.4)	2.30 (65.3)	26	16	13	14	20	10

