

SM

SM5 SERIES

5/32" DIAMETER CABLE

Design Data Sheet

Square Mount Isolator

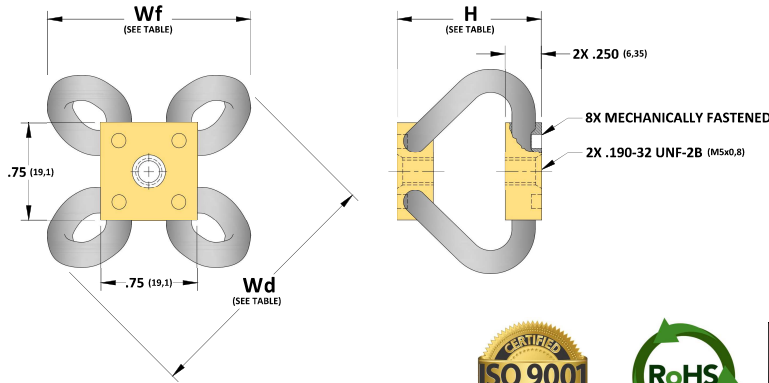

PART NUMBER	DIMENSIONS in (mm)			ISOLATOR WEIGHT oz (gms)	COMPRESSION		ROLL		COMPRESSION/ROLL	
	H ±.03	Wf (REF)	Wd (REF)		Kv (VIBE) (lbs/in)	Ks (SHOCK) (lbs/in)	Kv (VIBE) (lbs/in)	Ks (SHOCK) (lbs/in)	Kv (VIBE) (lbs/in)	Ks (SHOCK) (lbs/in)
SM5-100-A	1.00 (25.4)	1.71 (43.4)	2.24 (56.9)	0.80 (22.7)	94	74	54	57	64	50
SM5-120-A	1.20 (30.5)	1.90 (48.3)	2.50 (63.5)	1.00 (28.4)	60	46	31	34	45	31
SM5-145-A	1.45 (36.8)	2.10 (53.3)	2.73 (69.3)	1.10 (31.2)	40	23	20	20	28	18

NOTES, FEATURES, MATERIALS/FINISHES

NOTES:

- ALL DIMENSIONS IN PARENTHESIS ARE METRIC (mm)
- SPECIALS AVAILABLE UPON REQUEST (MATERIALS, SIZE, MOUNTING HOLES, FINISH, ETC...)
- ADD 'M' TO END OF PART NUMBER FOR METRIC INSERTS

FEATURES:

- RUGGED ALL METAL CONSTRUCTION
- UNEQUALLED TEMP. RANGE: -200°F TO 500°F
- THREE AXIS CAPABILITY (6 DOF)
- HIGH DAMPING: C/Cc ≈ .15-.20
- LONG LIFE AND MAINTENANCE FREE

MATERIALS/FINISHES:

- CABLE: 300 SERIES SS PER MIL-W-83420 OR RR-W-410
- INSERTS: 300 SERIES SS PER MS124655
- RETAINER BARS: 6063-T52 ALUMINUM ALLOY/CHEM FILM IAW MIL-C-5541, CLASS 1A

