

**ELECTRIC  
ACTUATORS**

**NEW**

# Economy series

Economy Series

**ET**

A thin-and-light turntable that Utilizes cross roller rings for the rotation mechanism



Cross Roller Ring

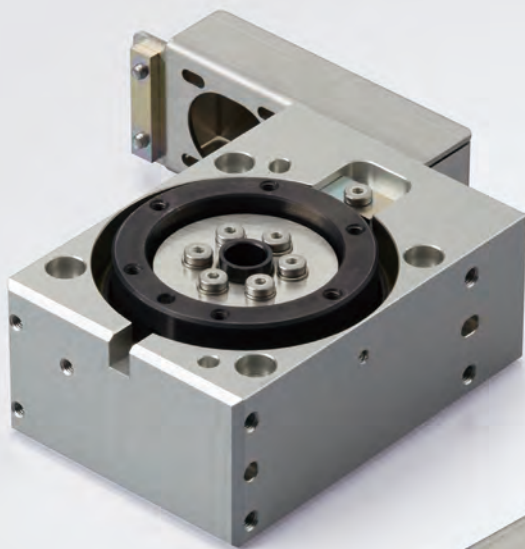

Motor-less Specifications



TSC Specifications

For details, visit THK at [www.thk.com](http://www.thk.com)

\* Product information is updated regularly on the THK website.

**THK CO., LTD.**  
TOKYO, JAPAN

CATALOG No.397-1E

## Economy Series

## ET

A thin-and-light turntable that utilizes cross roller rings for the rotation mechanism

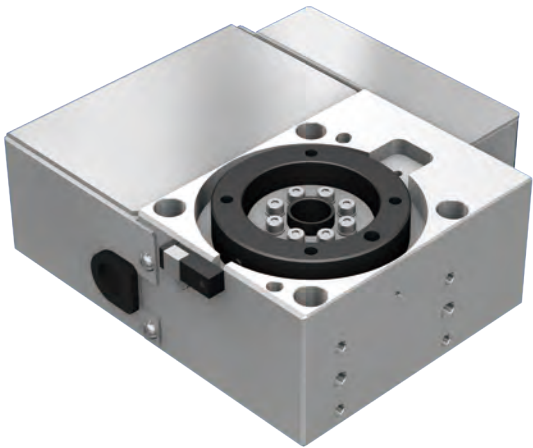

TSC Specifications

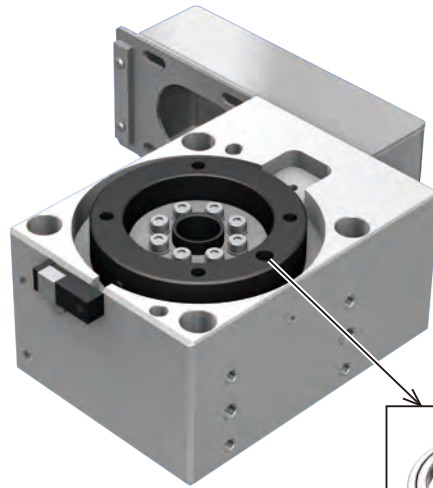

Motor-less Specifications



Cross Roller Ring

## Features

### Slim-and-Light Structure

Cross roller rings are used for the rotating mechanism to support load in every direction such as radial loads, axial loads, and moment loads while achieving a lower profile and lighter form.

## Product Usage Example

Pick &amp; Place

Transport

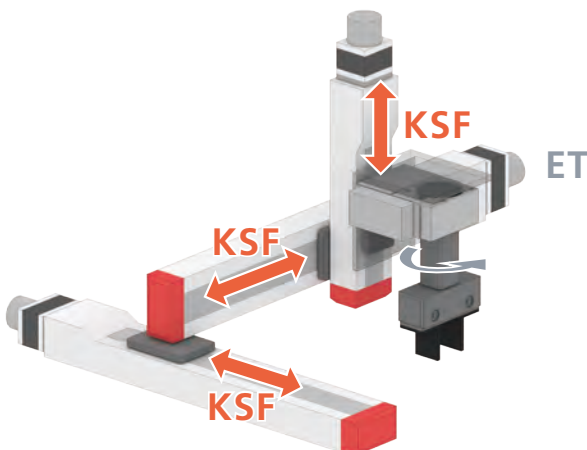

Model Number Used

KSF ET

High speed KSF and compact and lightweight ET are used to enhance the productivity.

## Product Lineup

Available in 2 models (ET20 / ET35). It can be selected from a single rotation (330°) specification and multi-rotation specification according to the application.

In addition, it can be combined with a dedicated driver controller (TSC), or the motor-less type (machine only) can be selected.

## Model Configuration

### ET (TSC Specifications)

When combining with dedicated driver controller

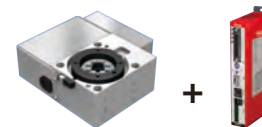

Model	Reduction ratio	Stroke	Control device	Sensors	Motor size	Home position	Cable length
ET20	45	330	TS		20P	D00	S3
(1)	(2)	(3)	(4)	(5)	(6)	(7)	(8)
ET20	20: 1/20	330: 330°	TS: TSC	No symbol: None 330°	20P: Stepper motor <input type="checkbox"/> 20	No symbol: Multi-rotation specifications	No symbol: None
ET35	30: 1/30 45: 1/45	360: Multi-rotation specifications		U: Sensor multi-rotation specifications	35P: Stepper motor <input type="checkbox"/> 35	D00: Home at CCW 330° R00: Home at CW 330°	S3: Standard 3 m S5: Standard 5 m SA: Standard 10 m

<p>The reduction ratio you can select differs depending on models. ET20: 45 ET35: 20, 30</p>	<p>Motors you can select differs depending on models. ET20: 20P ET35: 35P</p>	<p>D00 and R00 are mechanical home seeking. The CW and CCW directions of the home position are when the machine (ET main unit) is viewed from the top. Those with no symbol exclusively have the multi-rotation specifications.</p>	<p>Indicates the type and length of attached cables.</p>
--	---	---	--

### ET (type without motor)

In the case of actuator main unit only, or when the motor specified by the customer is installed

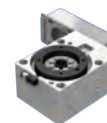

Model	Reduction ratio	Stroke	With/without motor	Motor plate	Option
ET20	45	360	0	A	U
(1)	(2)	(3)	(4)	(5)	(6)
ET20	20: 1/20	330: 330°	0: Without motor	A: Standard	No symbol: None 330°
ET35	30: 1/30 45: 1/45	360: Multi-rotation specifications	1: With motor (Prepared by THK)		U: Sensor multi-rotation specifications

<p>The reduction ratio you can select differs depending on models. ET20: 45 ET35: 20, 30</p>	<p>If "0" is selected, a timing pulley and timing belt are provided. When selecting "1", the motor you specify will be installed.</p>	<p>The sensor is Asa Electronics Industry's AH003.</p>
--	---	--

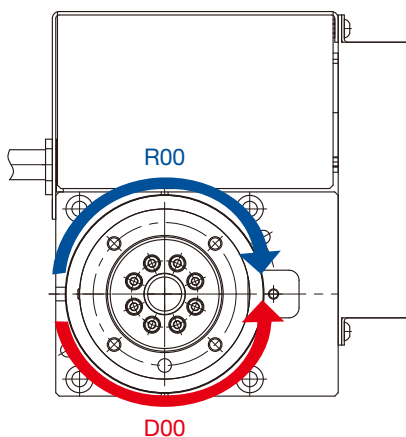

# ET20 TSC specifications

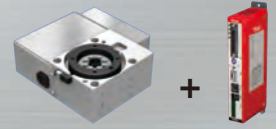

## Model Configuration

Model	Reduction ratio	Stroke	Control device	Sensors	Motor size	Home position	Cable length
ET20	45	330	TS		20P	D00	S3
<b>ET20</b>	<b>45: 1/45</b>	<b>330: 330°</b> <b>360: Multi-rotation specifications</b>	<b>TS: TSC</b>	<b>No symbol: None</b> <b>330°</b> <b>U: Sensor multi-rotation specifications</b>	<b>20P: Stepper motor □ 20</b>	<b>No symbol: Multi-rotation specifications</b> <b>D00: Home at CCW 330°</b> <b>R00: Home at CW 330°</b>	<b>No symbol: None</b> <b>S3: Standard 3 m</b> <b>S5: Standard 5 m</b> <b>SA: Standard 10 m</b>

## Basic Specifications

Control device type	TSC
Motor	□20
Drive system	Hypoid gear
Output shaft bearing *1	Cross Roller Ring
Reduction ratio	1/45
Maximum allowable inertia moment [kg·m <sup>2</sup> ]	0.0057
Maximum output torque [N·m]	0.30
Maximum angular velocity [°/s]	270
Maximum angular acceleration [°/s <sup>2</sup> ]	2000
Positioning repeatability [°]	±0.04 or less
Home return accuracy [°]	±0.04 or less
Backlash *2 [°]	0.2 or less
Permissible axial load *3 *4 [N]	30
Permissible radial load *3 *4 [N]	13.2
Permissible moment *3 *4 [N·m]	3.6
Stroke: *5 [°]	330 or 360
Weight [kg]	0.52

\*1 The cross roller ring has positive clearance.

\*2 The backlash is the factory value at the stroke position using our predetermined measurement method. In certain usage conditions, the backlash may become large due to the wear of the hypoid gear.

\*3 The allowable load and permissible moment must be at the safety factor of 1.5 or higher.

\*4 The permissible value of the applied load in each direction.

\*5 The home sensor of 360° stroke (multi-rotation) is a magnetic proximity switch and uses magnets for the rotary table. The length of the magnetic proximity switch cable is 1 m. Home stoppers with 330° stroke is for home detection. Separately prepare a stopper for overrun prevention as required.

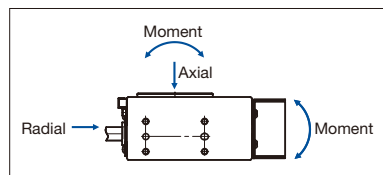

## Angular Velocity and Allowable Inertia Moment: Relationship Diagram

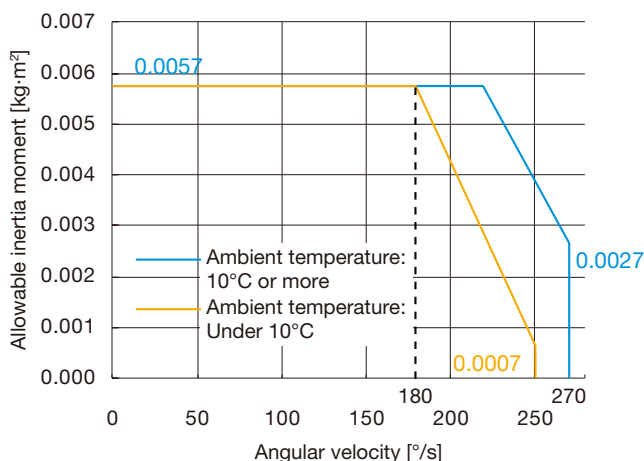

\* The relationship diagram is when the angular acceleration is 2000 °/s<sup>2</sup>.

\* If the ambient temperature is low (under 10°C), the allowable inertia moment at high angular velocity range will be smaller.

## Angular Velocity and Output Torque: Relationship Diagram

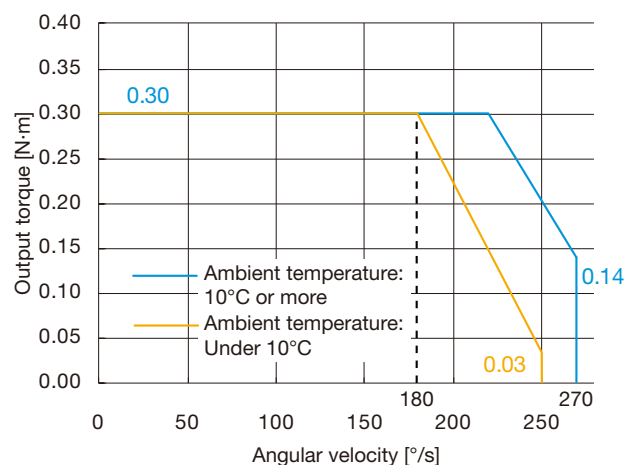

\* If the ambient temperature is low (under 10°C), the output torque at high angular velocity range will be lower.

\* Make sure that the output torque is at a safety factor of 1.5 or more.

ET20 + TSC



Dimensions

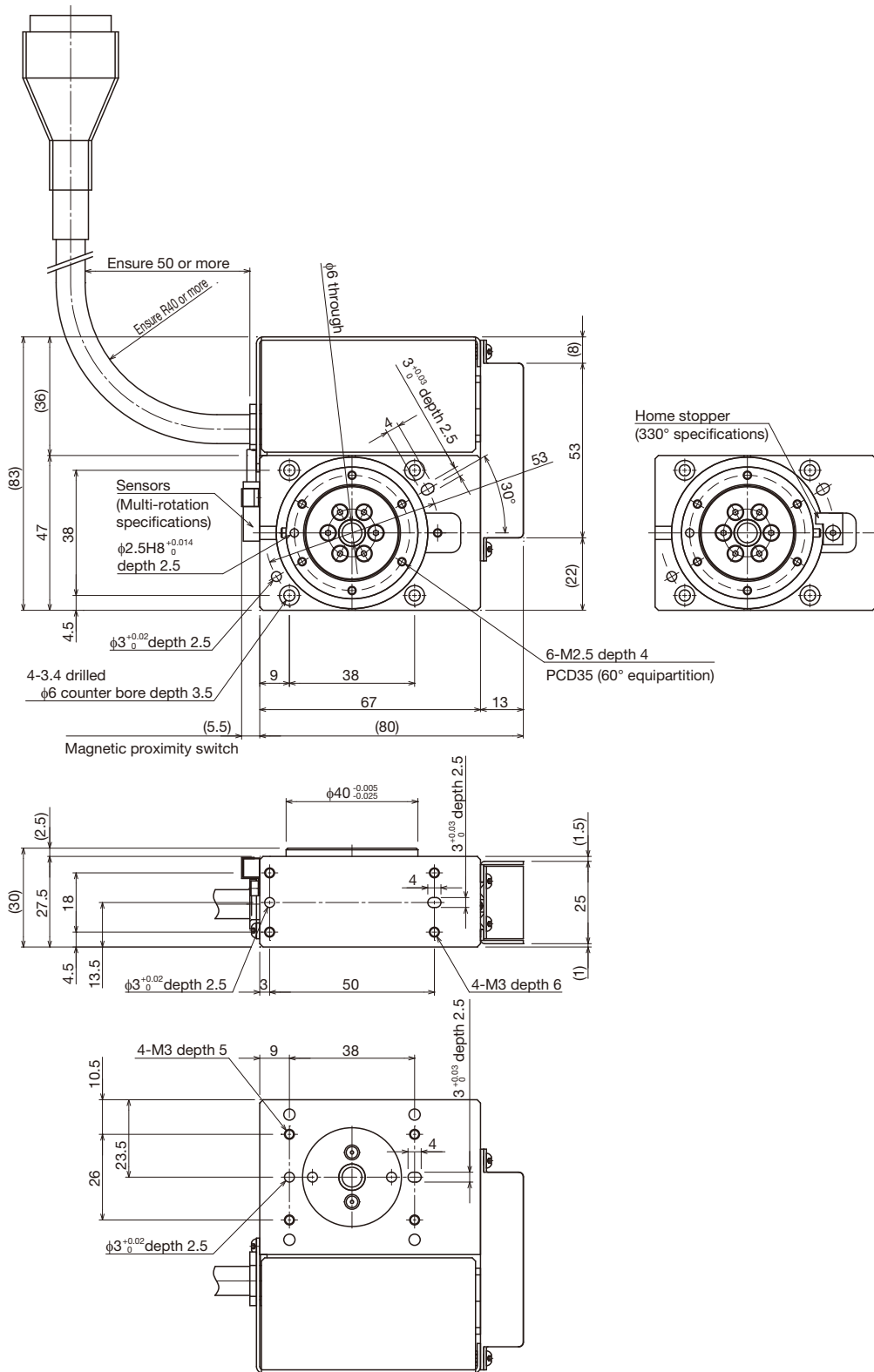



# ET35 TSC specifications

## Model Configuration

Model	Reduction ratio	Stroke	Control device	Sensors	Motor size	Home position	Cable length
ET35	20	330	TS		35P	D00	S3
<b>ET35</b>	20: 1/20 30: 1/30	330: 330° 360: Multi-rotation specifications	TS: TSC	No symbol: None 330° U: Sensor multi-rotation specifications	35P: Stepper motor □ 35	No symbol: Multi-rotation specifications D00: Home at CCW 330° R00: Home at CW 330°	No symbol: None S3: Standard 3 m S5: Standard 5 m SA: Standard 10 m

## Basic Specifications

Control device type	TSC	
Motor	□35	
Drive system	Hypoid gear	
Output shaft bearing *1	Cross Roller Ring	
Reduction ratio	1/20	1/30
Maximum allowable inertia moment [kg·m <sup>2</sup> ]	0.028	0.042
Maximum output torque [N·m]	2.2	3.3
Maximum angular velocity [°/s]	600	400
Maximum angular acceleration [°/s <sup>2</sup> ]	3000	
Positioning repeatability [°]	±0.04 or less	
Home return accuracy [°]	±0.04 or less	
Backlash *2 [°]	0.2 or less	
Permissible axial load *3 *4 [N]	200	
Permissible radial load *3 *4 [N]	88	
Permissible moment *3 *4 [N·m]	17.7	
Stroke: *5 [°]	330 or 360	
Weight [kg]	1.2	

\*1 The cross roller ring has an extra clearance.

\*2 The backlash is the factory value at the stroke position using our predetermined measurement method. In certain use conditions, the backlash may become large due to the wear of the hypoid gear.

\*3 The allowable load and permissible moment must be at the safety factor of 1.5 or higher.

\*4 A permissible value of the applied load in each direction.

\*5 The home sensor of 360° stroke (multi-rotation) is a magnetic proximity switch and uses magnets for the rotary table. The length of the magnetic proximity switch cable is 1 m. Home stoppers with 330° stroke is for home detection. Separately prepare a stopper for overrun prevention as required.

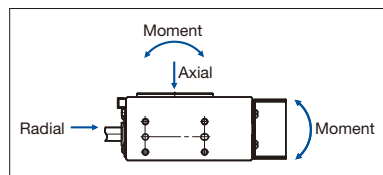

## Angular Velocity and Allowable Inertia Moment: Relationship Diagram

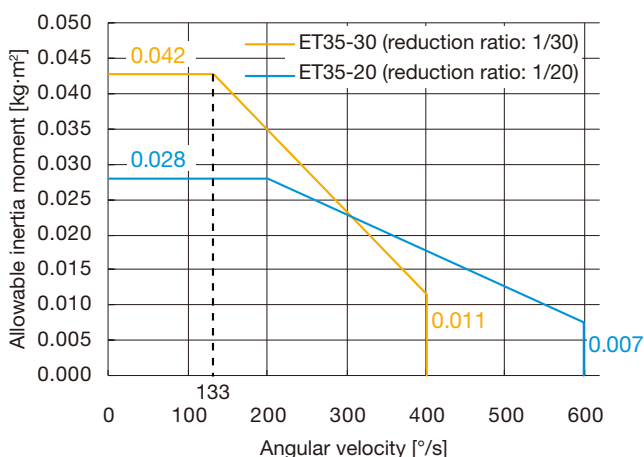

\* The relationship diagram is when the angular acceleration is 3000 °/s<sup>2</sup>.

## Angular Velocity and Output Torque: Relationship Diagram

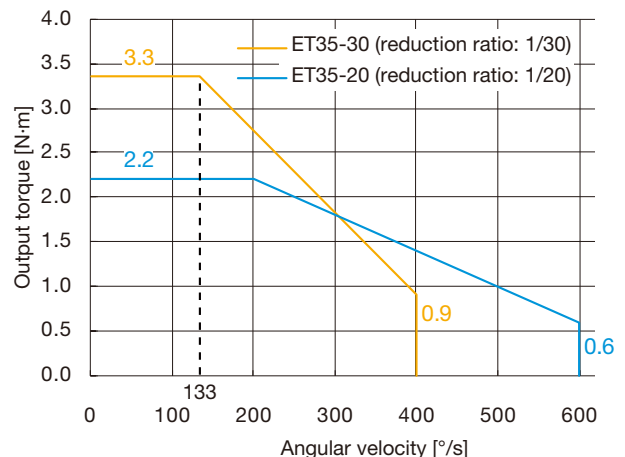

\* Make sure that the output torque is at the safety factor of 1.5 or more.

ET35 + TSC



Dimensions

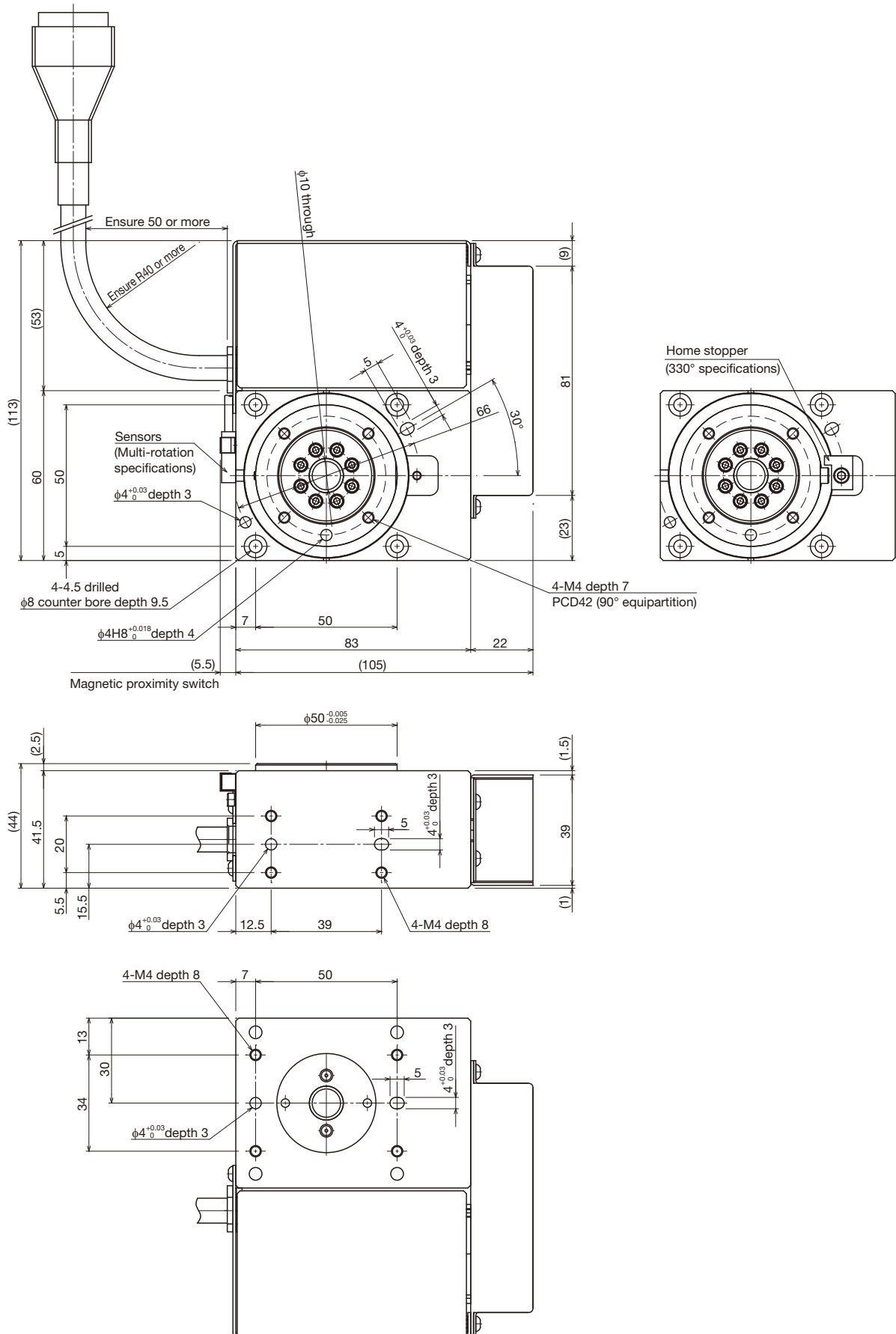

# ET20 Without Motor

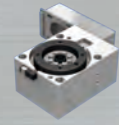

## Model Configuration

Model	Reduction ratio	Stroke	With/without motor	Motor plate	Option
ET20	45	360	0	A	U
ET20	45: 1/45	330: 330° 360: Multi-rotation specifications	0: Without motor 1: With motor (Prepared by THK)	A: Standard	No symbol: None 330° U: Sensor multi-rotation specifications

## Basic Specifications

Motor *1	□20
Drive system	Hypoid gear
Output shaft bearing *2	Cross Roller Ring
Reduction ratio	1/45
Maximum allowable inertia moment [kg·m <sup>2</sup> ]	0.0057
Maximum allowable load torque [N·m]	0.30
Maximum angular velocity [°/s]	270
Maximum angular acceleration [°/s <sup>2</sup> ]	2000
Positioning repeatability [°]	±0.04 or less
Backlash *3 [°]	0.2 or less
Permissible axial load *4 *5 [N]	30
Permissible radial load *4 *5 [N]	13.2
Permissible moment *4 *5 [N·m]	3.6
Stroke: *6 [°]	330 or 360
Permissible input torque [N·m]	0.039
Weight *7 [kg]	0.35

\*1 Mounted motor

Manufacturer Oriental Motor Co. Ltd.

Model PKP214D06 \*

Flange angle □20

A motor counterpart of TSC specifications. Consult each manufacturer for further details. To select a motor other than the ones listed above, contact THK.

\*2 The cross roller ring has an extra clearance.

\*3 The backlash is the factory value at the stroke position using our predetermined measurement method. In certain use conditions, the backlash may become large due to the wear of the hypoid gear.

\*4 The allowable load and permissible moment must be at the safety factor of 1.5 or higher.

\*5 A permissible value of the applied load in each direction.

\*6 The optional home sensor of 360° stroke (multi-rotation) is a magnetic proximity switch and uses magnets for the rotary table. The length of the magnetic proximity switch cable is 1 m.

Home stoppers with 330° stroke is for home detection. Separately prepare a stopper for overrun prevention as required.

\*7 The weight does not include the motor.

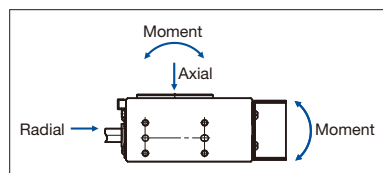

## Angular Velocity and Allowable Inertia Moment: Relationship Diagram

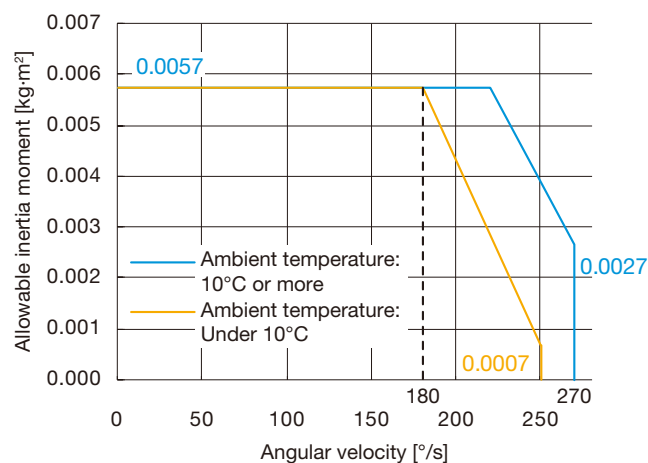

\* The relationship diagram is when the angular acceleration is 2000 °/s<sup>2</sup>.

\* If the ambient temperature is low (under 10°C), the allowable inertia moment at high angular velocity range will be smaller.

## Angular Velocity / Allowable Load Torque: Relationship Diagram

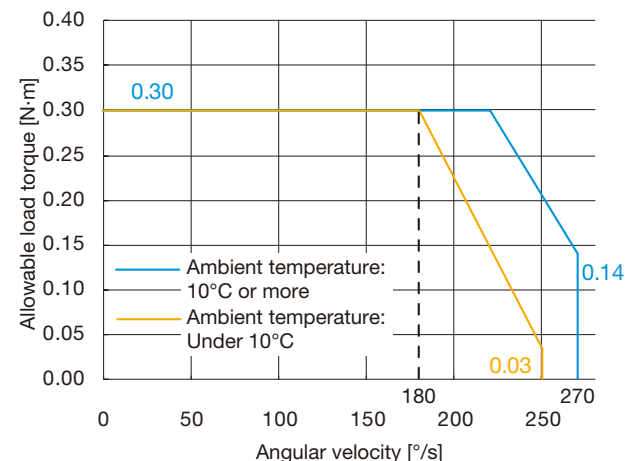

\* If the ambient temperature is low (under 10°C), the allowable load torque at high angular velocity range will be lower.

\* Make sure that the allowable load torque is at the safety factor of 1.5 or more.



ET20

Dimensions

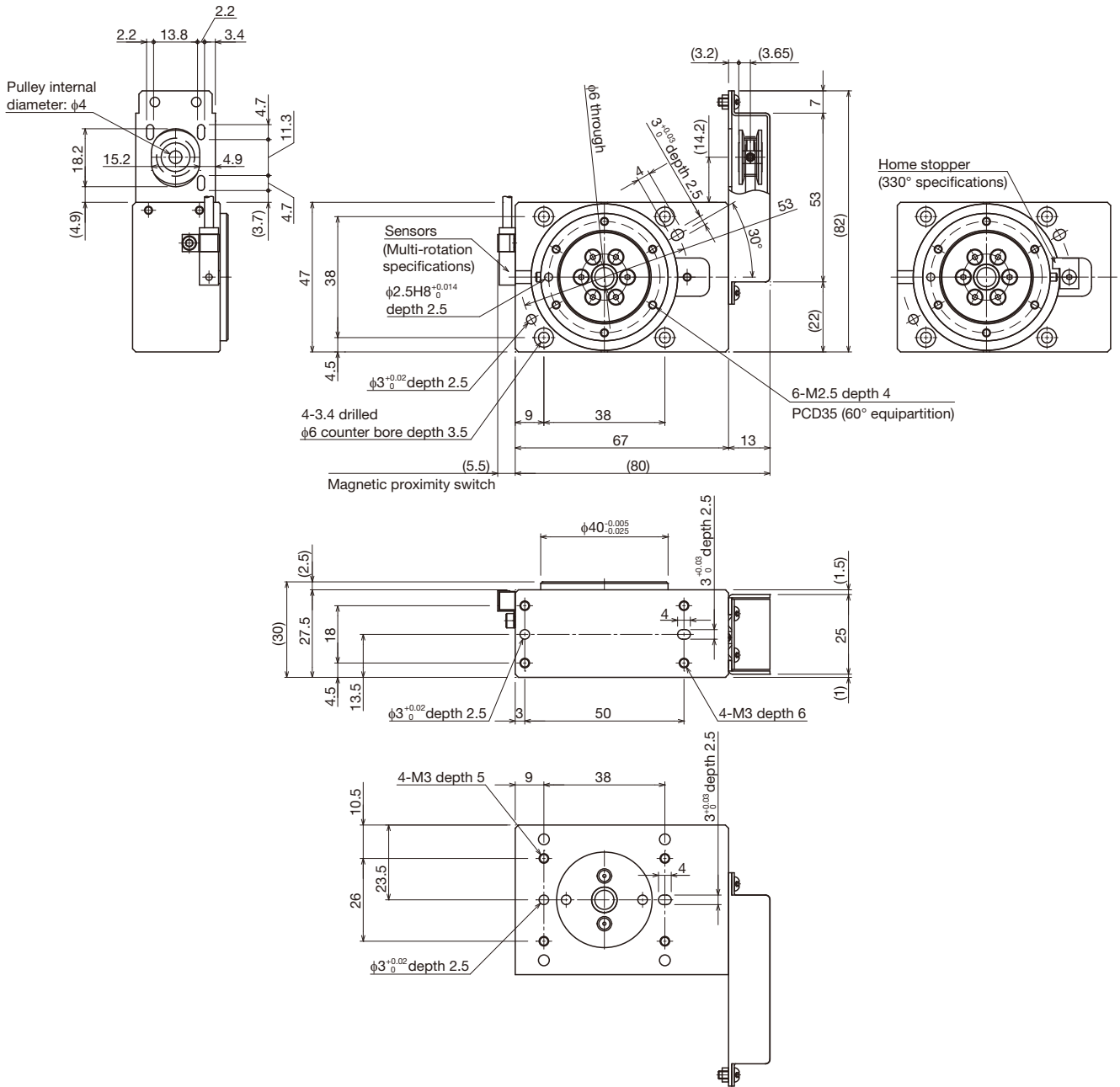

# ET35 Without Motor

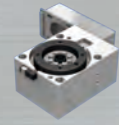

## Model Configuration

Model	Reduction ratio	Stroke	With/without motor	Motor plate	Option
ET35	20	360	0	A	U
<b>ET35</b>	20: 1/20 30: 1/30	330: 330° 360: Multi-rotation specifications	0: Without motor 1: With motor (Prepared by THK)	A: Standard	No symbol: None 330° U: Sensor multi-rotation specifications

## Basic Specifications

Motor *1	□35	
Drive system	Hypoid gear	
Output shaft bearing *2	Cross Roller Ring	
Reduction ratio	1/20	1/30
Maximum allowable inertia moment [kg·m <sup>2</sup> ]	0.028	0.042
Maximum allowable load torque [N·m]	2.2	3.3
Maximum angular velocity [°/s]	600	400
Maximum angular acceleration [°/s <sup>2</sup> ]	3000	
Positioning repeatability [°]	±0.04 or less	
Backlash *3 [°]	0.2 or less	
Permissible axial load *4 *5 [N]	200	
Permissible radial load *4 *5 [N]	88	
Permissible moment *4 *5 [N·m]	17.7	
Stroke: *6 [°]	330 or 360	
Permissible input torque [N·m]	0.248	
Weight *7 [kg]	0.8	

\*1 Mounted motor

Manufacturer Oriental Motor Co. Ltd.  
Model CVK235 \*  
Flange angle □35

A motor counterpart of TSC specifications. Consult each manufacturer for further details. To select a motor other than the ones listed above, contact THK.

\*2 The cross roller ring has an extra clearance.

\*3 The backlash is the factory value at the stroke position using our predetermined measurement method. In certain use conditions, the backlash may become large due to the wear of the hypoid gear.

\*4 The allowable load and permissible moment must be at the safety factor of 1.5 or higher.

\*5 A permissible value of the applied load in each direction.

\*6 The optional home sensor of 360° stroke (multi-rotation) is a magnetic proximity switch and uses magnets for the rotary table. The length of the magnetic proximity switch cable is 1 m.

Home stoppers with 330° stroke is for home detection. Separately prepare a stopper for overrun prevention as required.

\*7 The weight does not include the motor.

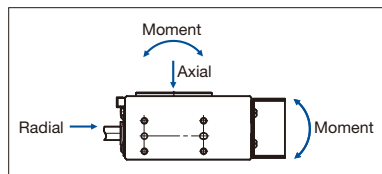

## Angular Velocity and Allowable Inertia Moment: Relationship Diagram

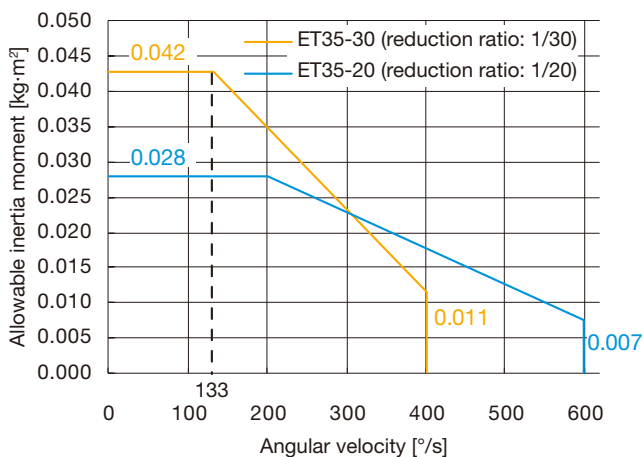

\* The relationship diagram is when the angular acceleration is 3000 °/s<sup>2</sup>.

## Angular Velocity / Allowable Load Torque: Relationship Diagram

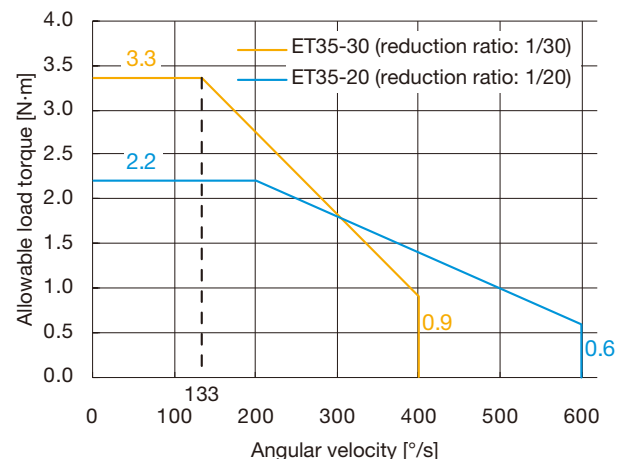

\* Make sure that the allowable load torque is at the safety factor of 1.5 or more.

# ET35

## Dimensions

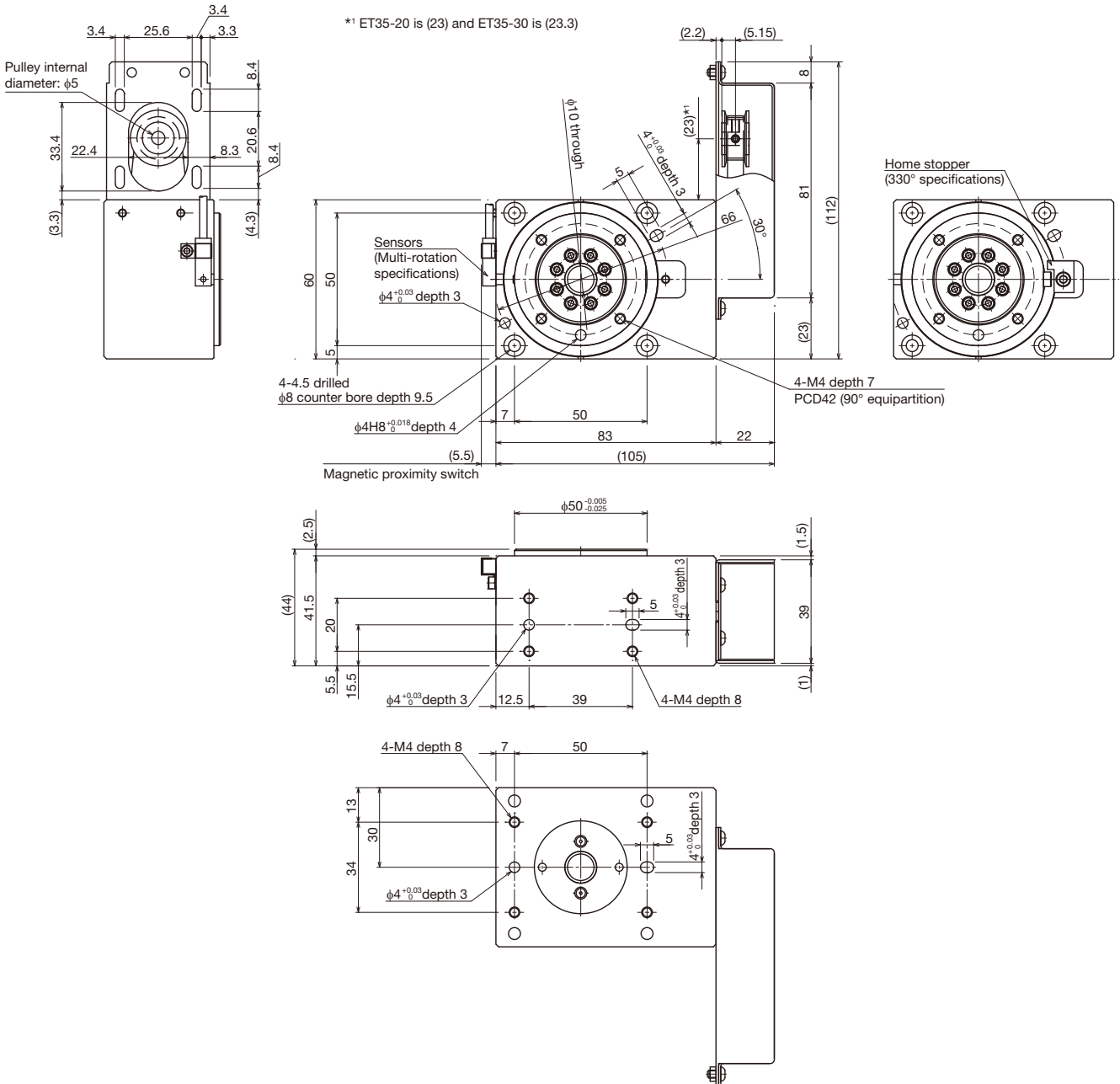

## Stepper Driver Controller

# TSC

Position Type for Single Axis



### Features

Ready to use by simplified setup.

### Simple Operation

Use PC setup tool D-STEP to access many useful functions.

### Functions

- Function select mode  
(64-position, external unit input instruction, 256-position, solenoid mode 1, solenoid mode 2)
- Step data count: Up to 256 (depending on function mode)
- Alarm history: Up to 50 (including power ON history)
- Switching between Auto/Manual, brake release switch
- Selectable control methods (positioning or pressing)
- Home sensor return method (only when combined with ET)

### Precautions on Use

Please note that actuators such as ES, EC and KRF cannot be operated using the TSC controller for ET.

- \* The TSC controllers for ET have "ET20" and "ET35" written in the number configuration of compatible actuator models.

Information is repeated and confusing.

- \* To use a 10 m actuator cable, please insert a noise filter into the TSC power supply.  
Recommended noise filter is "RSAN-2003 (TDK-Lambda Corporation)".

## Model Configuration

● Stepping Driver Controller \*Separate order is required.

Model	Current value	Design symbol	Type	Compatible actuator *1	Reduction ratio	Stroke	Home return direction
TSC	015	B	MOD	ET20	45	330	D
(1)	(2)	(3)	(4)	(5)	(6)	(7)	(8)
TSC	015: 1.5A	B	MOD: Mode switching type	ET20	20: 1/20	330: 330°	D: CCW
				ET35	30: 1/30	360: Multi-rotation specifications	R: CW
					45: 1/45		

\*1 Please note that actuators such as ES, EC and KRF cannot be operated when the compatible actuator is ET20 or ET35.

## Specifications

Basic Specifications	Input power supply		24V DC ± 10% (up to 2.5 A)				
	Control axis		1 axis				
Control	Motor type		Stepping motor (□20mm, □35mm)				
	Control method		Feedback control (Semi-closed loop)				
	Position detection method		Incremental				
	Acceleration/deceleration method		Trapezoid acceleration				
Program	Function Mode		64-position	External unit input	256-position	Solenoid mode 1	Solenoid mode 2
	Step data count		64 points	64 points	256 points	7 points	3 points
	Data input/output method		PC setup tool D-STEP				
Input/output	Dedicated input/output	Input point	16 points (Start, Return to home position, Pause, Reset, Servo ON, Specify step number, etc.) *				
		Output point	16 points (Return to home position completed, In position, Servo ready, Alarm, Emergency stop, etc) *				
Input/output power supply		24V DC ± 10% (This should be prepared by yourself.)					
Communication	Serial communication	Connected device	PC setup tool D-STEP				
		Communication method	RS-485				
		Port count	Mini DIN × 1				
Usage conditions	Operating/storage temperature		0 to 40°C (No freezing)/-20 to 85°C (No freezing)				
	Operating humidity/Storage humidity		90% RH or below (No condensation)				
	Ambient condition		Indoor (Free from direct sunlight, corrosive gas, flammable gas, oil mist)				
General specifications	Protective function		Overload, overvoltage, excessive position deviation, software limit over error, etc.				
	Accessories		Power connector × 1 I/O connector × 1				
	Options (sold separately)		I/O cable: 3 m, 5 m, 7 m, 10 m PC communication cable (mini DIN <-> USB)				
	External dimensions		32 mm (W) × 192.2 mm (H) × 77.6 mm (D)				
	Weight		300 g or less				

\* Varies depending on function mode.

## System Configuration

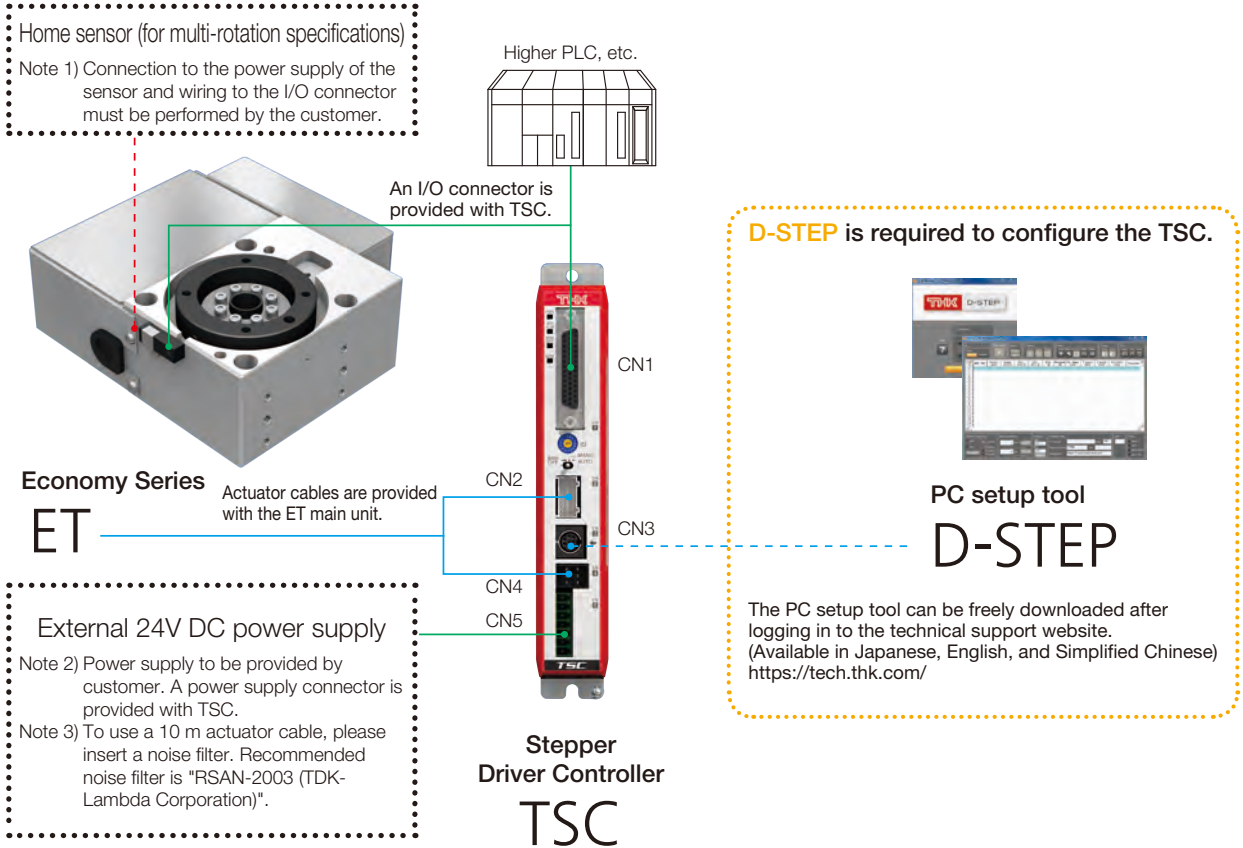

- Wiring to be provided by customer.
- - - Separate order required.
- Cables provided with product.

## Dimensional Drawing of Controller

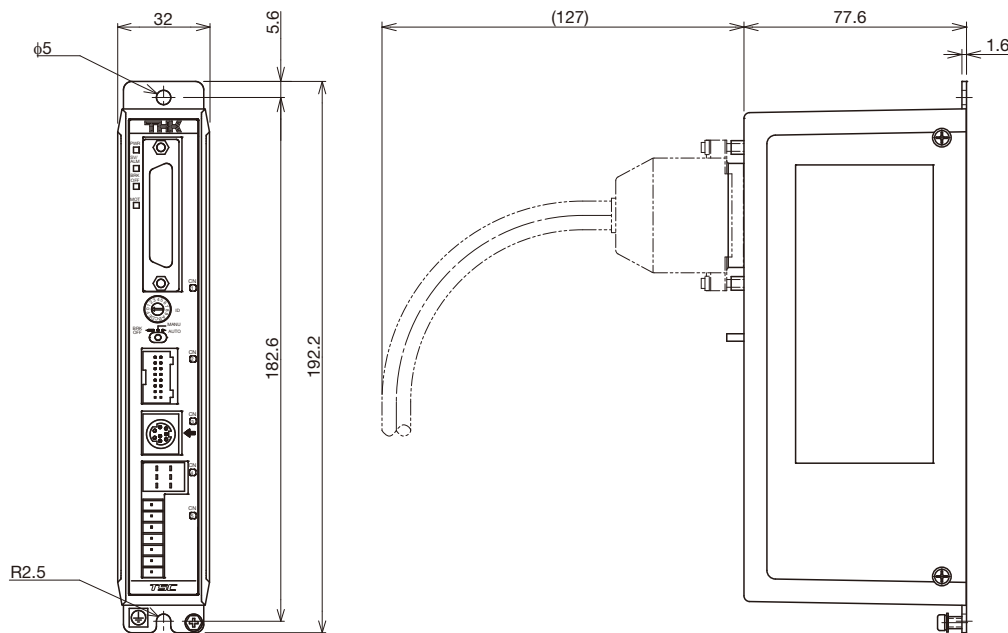

\* Contact THK for details on the dimensional drawing.

# TSC Pin Assignment

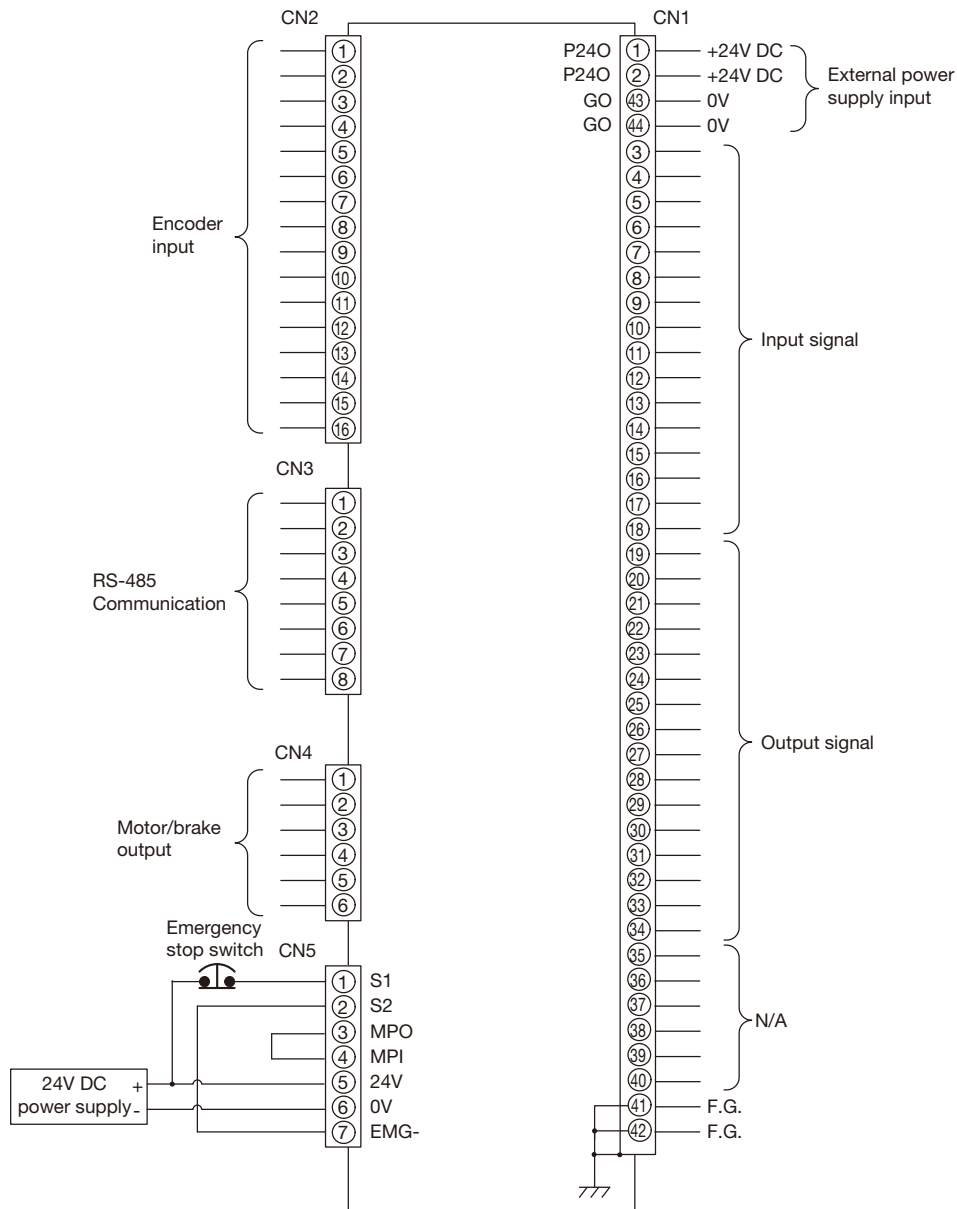

\* For attached I/O connector pin numbers, see P16.

\* Customer provides 24V DC power supply for input/output circuitry.

## Input/Output Circuitry for TSC (CN1)

Input circuit

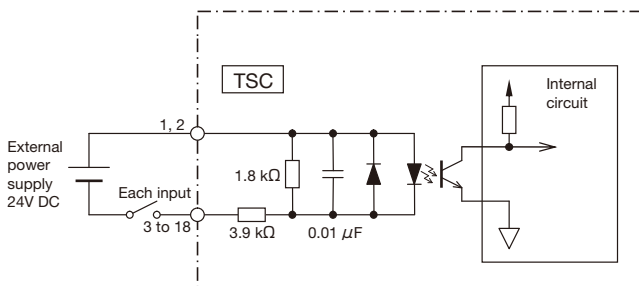

Output circuit

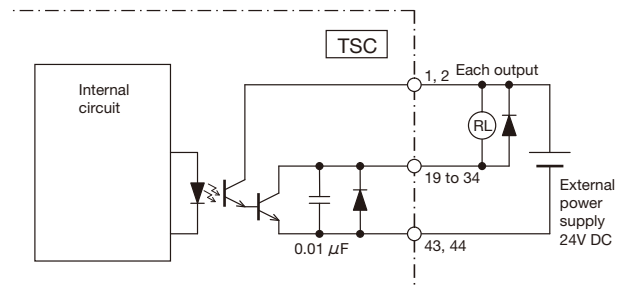

## TSC Function Mode

For TSC, five modes are provided to support various requirements and purposes.

Function Mode	Overview	Step data count	Pressing operation
Multi-point positioning type	0: 64-position Multi-point positioning operation with 64 points With area output, with P area output	64	○
	1: External unit input Multi-point positioning operation with 64 points I/O-based external unit instruction mode Without area output, with P area output	64	-
	2: 256-position Multi-point positioning operation with 256 points Without area output, with P area output	256	○
Electromagnetic valve type	4: Solenoid mode 1 Multi-point positioning operation with 7 points Direct move command input With area output, with P area output	7	○
	5: Solenoid mode 2 Multi-point positioning operation with 3 points Direct move command input With position sensor auto-switch output, area output and P area output	3	-

## TSC Pin Assignment by Function Mode

I/O	CN1 Pin number	Signal name					
		Function mode "0" 64-position	Function mode "1" External unit input	Function mode "2" 256-position	Function mode "4" Solenoid mode 1	Function mode "5" Solenoid mode 2	
Input	3	PI 0	PI 0	PI 0	ST 0	ST 0	
	4	PI 1	PI 1	PI 1	ST 1	ST 1	
	5	PI 2	PI 2	PI 2	ST 2	ST 2	
	6	PI 3	PI 3	PI 3	ST 3	-	
	7	PI 4	PI 4	PI 4	ST 4	-	
	8	PI 5	PI 5	PI 5	ST 5	-	
	9	-	MODE	PI 6	ST 6	-	
	10	-	JOG/INCHING	PI 7	-	-	
	11	SENSOR	SENSOR	SENSOR	SENSOR	SENSOR	
	12	BKRL	JOG N	BKRL	BKRL	BKRL	
	13	STRT	STRT/PWRT	STRT	-	-	
	14	MANU	MANU	MANU	MANU	MANU	
	15	HOME	HOME	HOME	HOME	HOME	
	16	PAUSE	PAUSE	PAUSE	PAUSE	PAUSE	
	17	REST	REST	REST	REST	REST	
	18	SV-ON	SV-ON	SV-ON	SV-ON	SV-ON	
	Output	19	PO 0	PO 0	PO 0	PE 0	LS 0
		20	PO 1	PO 1	PO 1	PE 1	LS 1
21		PO 2	PO 2	PO 2	PE 2	LS 2	
22		PO 3	PO 3	PO 3	PE 3	-	
23		PO 4	PO 4	PO 4	PE 4	-	
24		PO 5	PO 5	PO 5	PE 5	-	
25		MOVE	MOVE	PO 6	PE 6	-	
26		AREA	MODES	PO 7	AREA	AREA	
27		P AREA	P AREA	P AREA	P AREA	P AREA	
28		MANU S	MANU S	MANU S	MANU S	MANU S	
29		HEND	HEND	HEND	HEND	HEND	
30		INPS	INPS	INPS	INPS	-	
31		LOAD/TRQS	WEND	LOAD/TRQS	LOAD/TRQS	-	
32		SVRDY	SVRDY	SVRDY	SVRDY	SVRDY	
33		EMGS	EMGS	EMGS	EMGS	EMGS	
34		ALM	ALM	ALM	ALM	ALM	



## Detailed Specifications of Input Signal Functions

Input		
Signal name	Description	Remarks
MANU	Operation mode	Switches AUTO/MANUAL from I/O. MANUAL when signal is on, AUTO when off.
STRT	Start	Start signal of program step. Program starts when signal is on.
PI0 to PI7	Instruction position number	Input for specifying position numbers. Specifies programs at each signal level. Selects a program step and starts a program with "STRT" signal.
PAUSE	Pause	Temporarily interrupts the operation. PAUSE input status when signal is off. (N.C. connection specification)
HOME	Return to home position	Starts the return to home position operation. Returning to home position is started when signal is on. It stops when it is off.
SV-ON	Servo on	Turns the servo ON and OFF. Servo ON when signal is on, and servo OFF when signal is off.
REST	Alarm reset	Resets alarm. Resets remaining travel distance during pause. Resets when it is on.
BKRL	Brake release	Forcibly releases brake. Releases brake when it is on.
MODE	External unit input instruction mode	Enters the instruction mode when signal is on. Instruction mode when signal is on.
PWRT	Current position write with external unit input instruction	During the instruction mode, the position is written when this signal is greater than 20 ms with the position for writing specified.
JOG/INCHING	Manual operation switch with external unit input instruction	Switching of manual operation during the instruction mode. Selects inching operation when it is on, and jog operation when it is off.
JOG P	Moving direction + with external unit input instruction	Operating direction and operation start signal during the instruction mode. Moves in + direction to the soft limit when signal is on. Decelerates and stops when it is off while moving.
JOG N	Moving direction - with external unit input instruction	Operating direction and operation start signal during the instruction mode. Moves in - direction to the soft limit when signal is on. Decelerates and stops when it is off while moving.
ST0 to 6	Cylinder type START	Program start signal for position numbers from "ST0" to "ST6". Can select either Level or Edge for signal using parameter 13 "move" command. Note that when more than two positions are on at the same time, the lowest-number signal takes precedence.
SENSOR	Sensor input	Input signal when sensor input method is selected for the home return method.

## Detailed Specifications of Output Signal Functions

Output		
Signal name	Description	Remarks
MANU S	Operation mode status	Operation mode status outputs (AUTO/MANUAL). MANUAL when signal is on, AUTO when off.
PO1 to PO7	End position number	Outputs the position number arrived after positioning is completed (binary outputs).
MOVE	Moving	Outputs signal during motor operation.
INPS	Positioning completed	Outputs when motor comes within the positioning completed width.
SVRDY	Operation preparations completed	Outputs signal when servo is on.
ALM	Alarm	Alarm output signal.
MODES	Operation mode status	Output signal for judging instruction mode or regular operation mode. Instruction mode when signal is on. Regular operation mode when it is off.
WEND	Writing completed	Signal is off after switching to the regular mode, and it is on for 30 ms when writing of the PWRT signal is completed.
HEND	Return to home position completed	Outputs signal when returning to home position is completed.
AREA	Upper/lower area limit	On when the current position of actuator is within a range specified by the parameter.
P AREA	Position area	On when the current position of actuator is within a range specified by the program step.
EMGS	Emergency stop status	Outputs judgment for input of emergency stop. On during normal operation, and off when emergency stop circuit is shut off.
LOAD	Load output judgment status	On when a directive torque exceeds the threshold over a certain period within a judgment range.
TRQS	Torque level status	On when the load threshold is reached while moving. Off while the load remains under the threshold.
PE0 to PE6	Cylinder type arrival completed output	Signal generated after operation for position number is completed.
LS0 to LS2	Cylinder type position detection output	Outputs when the current position comes within the positioning width for each of the three points.

## I/O Connector Pin Numbers

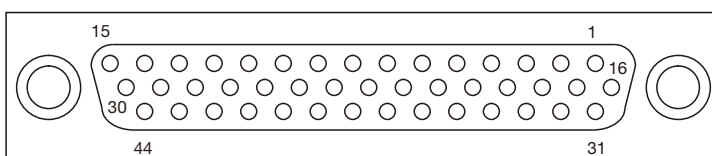

\* Controller connector port view.

## Actuator Cable

Actuator Cable for TSC:CBL-TSC-AC- \* \* -B (standard)

\* \* indicates cable length: 03 (3 m), 05 (5 m), or 10 (10 m).

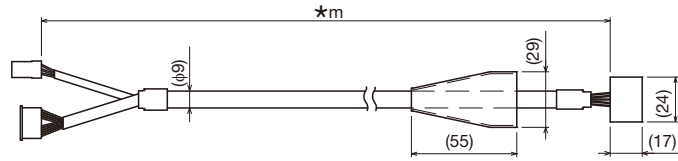

\* To use a 10 m actuator cable, please insert a noise filter the TSC power supply.  
 Recommended noise filter is "RSAN-2003 (TDK-Lambda Corporation)".

## Cable

I/O cable:CBL-CON-IO- \* \* (\* \* is the cable length: 03: (3 m), 05: (5 m), 10: (10 m))

(sold separately)

Can be used with the dedicated TSC driver controller.

\* Cables are shipped with the discrete wire side terminals unprocessed.

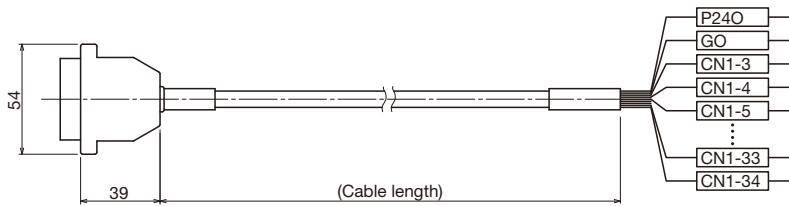

PC communications cable:CBL-COM-03

(sold separately)

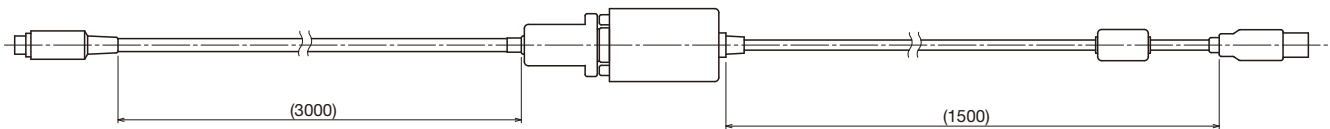

## D-STEP PC setup tool

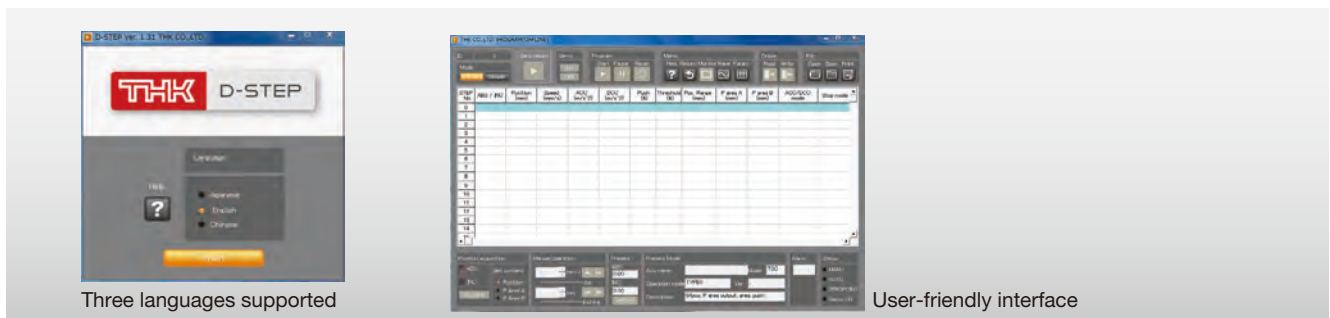

### Features

Supports multifunctional TSC/TLC/THC with user-friendly interface.

### Simple Operation

Operations and settings of TSC is possible using a PC.

Equipped with functions useful for maintenance, such as backing up data or logging operating states.

### Functions

- Checking, editing, backing up, or offline-editing of step data
- Checking, editing, backing up, or offline-editing of parameters
- Operations of actuator (Return to home position, Jog operation, Inching operation, Program execution, Servo ON/OFF)
- Monitor (I/O, Current position, Position command, Current command)
- Logging (Speed and current waveform display)
- Alarm (History display, Clear history, Alarm reset)
- Display language (Japanese / English / Chinese (simplified))

Supported OS: Windows XP/Windows Vista/Windows 7

D-STEP can be freely downloaded from the THK technical support website (<https://tech.thk.com/>).

\* TSC for ET is supported with Version 1.31 or later.

# MEMO

# MEMO

# MEMO



# Precautions on Use

## ● Operation

- Do not unnecessarily disassemble the actuator or control devices. Doing so may allow foreign objects to enter or reduce functionality.
- Do not drop or knock the actuator or control devices. Doing so may cause injury or damage the unit. If the product is dropped or impacted, functionality may be reduced even if there is no surface damage.
- If the product will be used in location exposed to vibrations or in special environment such as vacuum/clean-room, and/or high/low temperatures, contact THK.
- When using it mounted on the wall, be sure that the pulley side is not at the bottom.

## ● Environment

- Actuator: A place with an ambient temperature from 0 to 40°C and humidity of 80% RH or lower that will not expose the product to freezing or condensation.
- Controller: A place with an ambient temperature from 0 to 40°C and humidity of no more than 90% RH that will not expose the product to freezing or condensation.
- A place free from corrosive gas and flammable gas.
- A place free from electrically conductive powder (such as iron powder), dust, oil mist, moisture, salt, and organic solvent.
- A place free from direct sunlight and radiant heat.
- A place free from strong electric and magnetic fields.
- A place where vibration or impact is not transmitted to the unit.
- A place that is easily accessible for service and cleaning purposes.

## ● Safety Precautions

- When the actuator is in motion or about to be in motion, do not touch any moving parts. Do not go near the actuator when it is in motion.
- Before performing installation, adjustment, checking, or services regarding the actuator and the connected peripherals, ensure that all power is disconnected. In addition, take countermeasures to prevent anyone other than the operator from turning on the power.
- If two or more people are involved in the operation, confirm the procedures such as sequences, signs, and abnormalities in advance, and appoint another person for monitoring the operation.
- Before operation, please read thoroughly and obey "Manipulating industrial robots - Safety" (JIS B8433) and "Ordinance on Industrial Safety and Health" (Ministry of Health, Labor and Welfare).
- Operation of the actuator over the torque limit value leads to damage of parts or injury.
- Please keep the parameter torque limit settings within the allowable torque.
- Although a stopper is installed inside the product, it is intended to limit the stroke and therefore may be damaged in case of a hard collision.

## ● Lubrication

- Thoroughly wipe-off the anti-rust oil before using the product.
- In order to effectively use the ET, lubrication is required. Insufficient lubrication may increase abrasion on moving parts and shorten service life.
- Do not use a mix of lubricants with different physical properties.
- Please contact THK if using special lubricants.
- When adopting oil lubrication method, contact THK.
- The greasing interval may vary depending on the usage conditions, so THK recommends determining a greasing interval during the initial inspection.

## ● Storage

- When storing the actuator, enclose it in a package designated by THK and store it in a horizontal position away from abnormally high or low temperatures and high humidity.
- When storing the control devices, avoid abnormally high or low temperatures and high humidity.

- LM Guide, and  are registered trademarks of THK CO., LTD.
- The actual products may differ from the pictures and photographs in this catalog.
- Outward appearances and specifications are subject to change without notification for the purpose of improvement.
- Although great care has been taken in the production of this catalog, THK will not take any responsibility for damage resulting from typographical errors or omissions.
- In exporting our products and technology, or selling them for the purpose of export, THK has a basic policy of observing laws relating to foreign exchange, trade and other laws. For export of THK products as single items, please contact THK in advance.

All rights reserved.

# THK CO., LTD.

Head Office 3-11-6 Nishigotanda, Shinagawa-ku, Tokyo 141-8503 JAPAN

International Sales Department Phone:+81-3-5434-0351 Fax:+81-3-5434-0353

Global site : <http://www.thk.com/>

## NORTH AMERICA

THK America, Inc.

### ● HEADQUARTERS

Phone:+1-847-310-1111 Fax:+1-847-310-1271

### ● CHICAGO OFFICE

Phone:+1-847-310-1111 Fax:+1-847-310-1182

### ● NORTH EAST OFFICE

Phone:+1-631-244-1565 Fax:+1-631-244-1565

### ● ATLANTA OFFICE

Phone:+1-770-840-7990 Fax:+1-770-840-7897

### ● LOS ANGELES OFFICE

Phone:+1-949-955-3145 Fax:+1-949-955-3149

### ● SAN FRANCISCO OFFICE

Phone:+1-925-455-8948 Fax:+1-925-455-8965

### ● DETROIT OFFICE

Phone:+1-248-858-9330 Fax:+1-248-858-9455

### ● TORONTO OFFICE

Phone:+1-905-820-7800 Fax:+1-905-820-7811

## SOUTH AMERICA

THK BRAZIL INDUSTRIA E COMERCIO LTDA.

Phone:+55-11-3767-0100 Fax:+55-11-3767-0101

## EUROPE

THK GmbH

### ● EUROPEAN HEADQUARTERS

Phone:+49-2102-7425-555 Fax:+49-2102-7425-556

### ● DÜSSELDORF OFFICE

Phone:+49-2102-7425-0 Fax:+49-2102-7425-299

### ● STUTTGART OFFICE

Phone:+49-7141-4988-500 Fax:+49-7141-4988-888

### ● U.K. OFFICE

Phone:+44-1384-47-1550 Fax:+44-1384-47-1551

### ● ITALY OFFICE

Phone:+39-02-9901-1801 Fax:+39-02-9901-1881

### ● SWEDEN OFFICE

Phone:+46-8-445-7630 Fax:+46-8-445-7639

### ● AUSTRIA OFFICE

Phone:+43-7229-51400 Fax:+43-7229-51400-79

### ● SPAIN OFFICE

Phone:+34-93-652-5740 Fax:+34-93-652-5746

### ● TURKEY OFFICE

Phone:+90-216-362-4050 Fax:+90-216-569-7150

### ● PRAGUE OFFICE

Phone:+420-2-41025-100 Fax:+420-2-41025-199

### ● MOSCOW OFFICE

Phone:+7-495-649-80-47 Fax:+7-495-649-80-44

### THK Europe B.V.

### ● EINDHOVEN OFFICE

Phone:+31-040-290-9500 Fax:+31-040-290-9599

### THK France S.A.S.

### ● PARIS OFFICE

Phone:+33-1-7425-3800 Fax:+33-1-7425-3799

## CHINA

THK (CHINA) CO., LTD.

### ● HEADQUARTERS

Phone:+86-411-8733-7111 Fax:+86-411-8733-7000

### ● SHANGHAI OFFICE

Phone:+86-21-6219-3000 Fax:+86-21-6219-9890

### ● BEIJING OFFICE

Phone:+86-10-8441-7277 Fax:+86-10-6590-3557

### ● CHENGDU OFFICE

Phone:+86-28-8526-8025 Fax:+86-28-8525-6357

### ● GUANGZHOU OFFICE

Phone:+86-20-8523-8418 Fax:+86-20-3801-0456

### ● SHENZHEN OFFICE

Phone:+86-755-2642-9587 Fax:+86-755-2642-9604

### ● XIAN OFFICE

Phone:+86-29-8834-1712 Fax:+86-29-8834-1710

THK (SHANGHAI) CO., LTD.

Phone:+86-21-6275-5280 Fax:+86-21-6219-9890

## TAIWAN

THK TAIWAN CO., LTD.

### ● TAIPEI HEAD OFFICE

Phone:+886-2-2888-3818 Fax:+886-2-2888-3819

### ● TAICHUNG OFFICE

Phone:+886-4-2359-1505 Fax:+886-4-2359-1506

### ● TAINAN OFFICE

Phone:+886-6-289-7668 Fax:+886-6-289-7669

## KOREA

SEOUL REPRESENTATIVE OFFICE

Phone:+82-2-3468-4351 Fax:+82-2-3468-4353

## SINGAPORE

THK LM System Pte. Ltd.

Phone:+65-6884-5500 Fax:+65-6884-5550

## THAILAND

THK RHYTHM(THAILAND) CO., LTD. LM System Division

### ● Bangkok Branch

Phone:+66-2751-3001 Fax:+66-2751-3003

## INDIA

THK India Pvt. Ltd.

### ● HEADQUARTERS & Bangalore Branch

Phone:+91-80-2340-9934 Fax:+91-80-2340-9937

### ● Pune Branch

Phone:+91-20-4120-8742

### ● Chennai Branch

Phone:+91-44-4042-3132

### ● Ahmedabad Branch

Phone:+91-79-6134-4925

### ● Delhi Branch

Phone:+91-12-4676-8695