

# Model DC

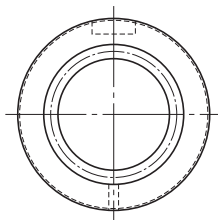

Lead Screw Nut  Model No.	Outer dimensions			Lead screw nut dimensions					
	Outer diameter		L	Keyway dimensions					
	D	Tolerance h9		0	b	Tolerance N9	t	ℓ	d
			0						
DC 12	22		22	4		2	16	1.5	1
DC 14	22	0	22	4	0	2	16	1.5	1
DC 16	28	-0.052	26	5	-0.030	2.5	18	1.5	1
DC 18	32		31	7		2.5	22	2	1
DC 20	32		31	7		2.5	22	2	1
DC 22	36	0	40	7	0	2.5	26	2.5	1
DC 25	36	-0.062	40	7	-0.036	2.5	26	2.5	1
DC 28	44		45	10		4	32	2.5	1.5
DC 32	44		45	10		4	32	2.5	1.5
DC 36	52		49	12		4.5	40	3	1.5
DC 40	58	0	57	15	0	5	42	3	1.5
DC 45	64	-0.074	62	15	-0.043	5	48	4	1.5
DC 50	68		67	15		5	52	4	1.5

Note1) Cut shafts (K) and ground shafts (G) are build-to-order. In the specification table, "standard shaft length" and "maximum shaft length" are values for rolled shafts (T).

For maximum shaft lengths of cut shafts (K) or ground shafts (G), contact THK.

Note2) The dynamic permissible thrust (F) indicates the torque at which the contact surface pressure on the screw tooth surface is 9.8 N/mm<sup>2</sup>. The maximum axial load (both when stopped and during operation) is set to the dynamic permissible thrust or below, and it must be selected while taking into consideration the safety factors of Table1 on **A16-5**.

## Model number coding

Combination of lead screw nut and screw shaft

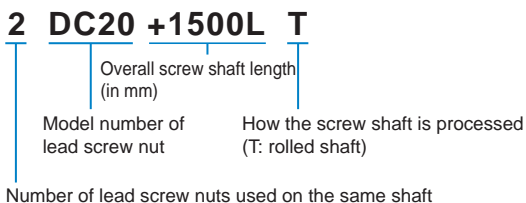

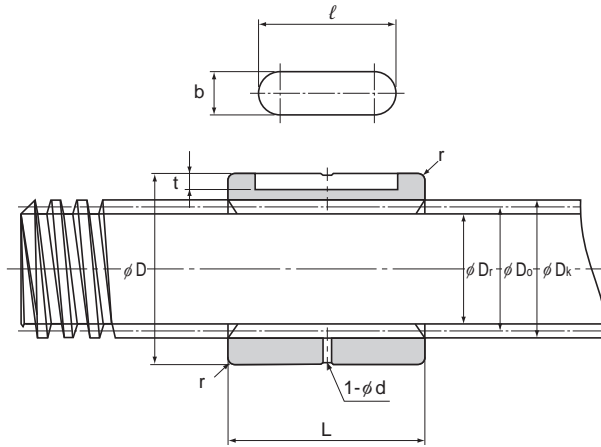

Unit: mm

Screw shaft	Screw shaft details						Standard shaft length	Maximum shaft length	Dynamic permissible thrust $F^{(note\ 2)}$ N	Mass	
	Model No. <small>(note)</small>	Outer diameter $D_k$	Effective diameter $D_o$	Thread minor diameter $D_r$	Lead R	Lead angle $\alpha$				Screw nut g	Screw shaft kg/m
CS 12	12	11	9.5	2	3°19'	1000	1500	2840	40	0.8	
CS 14	14	12.5	10.5	3	4°22'	1000	1500	3630	45	1	
CS 16	16	14.5	12.5	3	3°46'	1000	1500	4900	75	1.3	
CS 18	18	16	13.5	4	4°33'	1000	2000	6860	120	1.6	
CS 20	20	18	15.5	4	4°03'	1500	2000	7650	110	2	
CS 22	22	19.5	16.5	5	4°40'	1500	2500	9900	180	2.3	
CS 25	25	22.5	19.5	5	4°03'	1500	3000	11400	155	3.1	
CS 28	28	25.5	22.5	5	3°34'	2000	3000	14400	280	4	
CS 32	32	29	25.5	6	3°46'	2000	4000	17100	230	5.2	
CS 36	36	33	29.5	6	3°19'	2000	4000	21200	380	6.7	
CS 40	40	37	33.5	6	2°57'	2000	4000	27500	520	8.4	
CS 45	45	41	36.5	8	3°33'	3000	5000	34900	730	10.4	
CS 50	50	46	41.5	8	3°10'	3000	5000	42100	810	13	

## Model number coding

- Lead screw nut only

**DC20**

Model number of lead screw nut

- Screw shaft

**CS20 T +1500L**

Model number of screw shaft

How the screw shaft is processed (T: rolled shaft)

Overall screw shaft length (in mm)