

CSR

LM Guide Cross LM Guide Model CSR

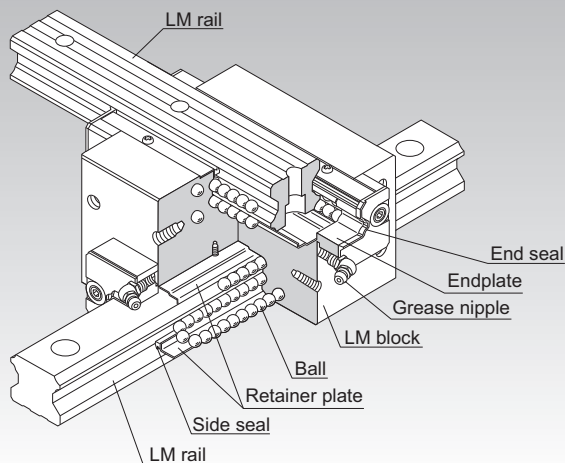

Point of Selection **A1-10**

Point of Design **A1-436**

Options **A1-459**

Model No. **A1-524**

Precautions on Use **A1-530**

Accessories for Lubrication **A24-1**

Mounting Procedure and Maintenance **B1-89**

Equivalent moment factor **A1-43**

Rated Loads in All Directions **A1-58**

Equivalent factor in each direction **A1-60**

Radial Clearance **A1-71**

Accuracy Standards **A1-79**

Shoulder Height of the Mounting Base and the Corner Radius **A1-445**

Permissible Error of the Mounting Surface **A1-452**

Dimensions of Each Model with an Option Attached **A1-472**

Structure and Features

Balls roll in four rows of raceways precision-ground on a LM rail and a LM block, and endplates incorporated in the LM block allow the balls to circulate. Since retainer plates hold the balls, they do not fall off even if the LM rail is pulled out.

This model is an integral type of LM Guide that squares an internal structure similar to model HSR, which has a proven track record and is highly reliable, with another and uses two LM rails in combination. It is machined with high precision so that the perpendicularity of the hexahedron of the LM block is within 2 μm per 100 mm in error. The two rails are also machined with high precision in relative straightness. As a result, extremely high accuracy in orthogonality is achieved. Since an orthogonal LM system can be achieved with model CSR alone, a conventionally required saddle is no longer necessary, the structure for X-Y motion can be simplified and the whole system can be downsized.

[4-way Equal Load]

Each row of balls is placed at a contact angle of 45° so that the rated loads applied to the LM block are uniform in the four directions (radial, reverse radial and lateral directions), enabling the LM Guide to be used in all orientations.

[High Rigidity]

Since balls are arranged in four rows in a well-balanced manner, this model is stiff against a moment, and smooth straight motion is ensured even a preload is applied to increase the rigidity. The rigidity of the LM blocks is 50% higher than that of a combination of two HSR LM blocks secured together back-to-back with bolts. Thus, CSR is an optimal LM Guide for building an X-Y table that requires high rigidity.

Types and Features

Model CSR-S

This model is a standard type.

Specification Table⇒ [A1-296](#)

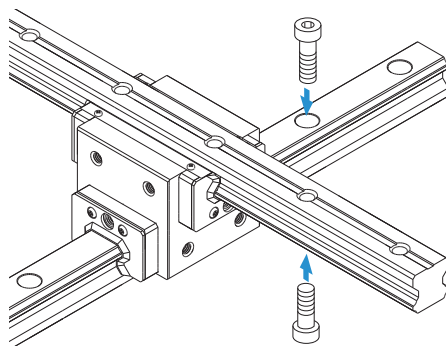

Model CSR

It has a longer overall LM block length (L) and a greater rated load.

Specification Table⇒ [A1-296](#)

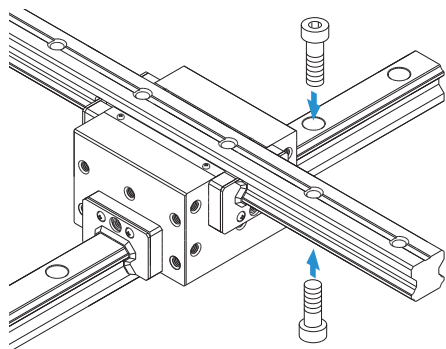

Drawing of Using an Inner Saddle

Model CSR can easily be assembled and adjusted by using an inner saddle to link four LM blocks together. When installed on an inner saddle, model CSR achieves a highly accurate X-Y guide and high rigidity moment in the yawing direction (as indicated by the arrow in the figure).

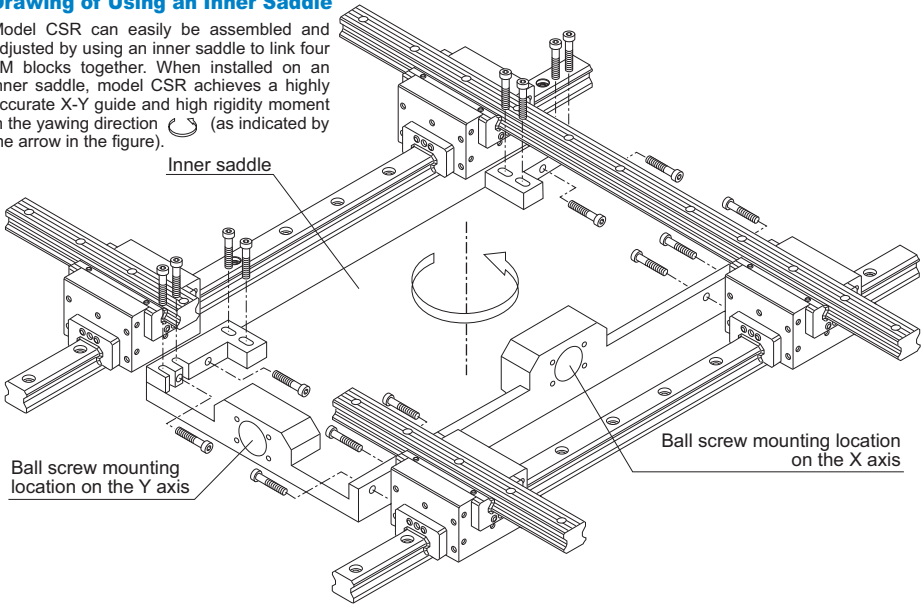

Model CSR

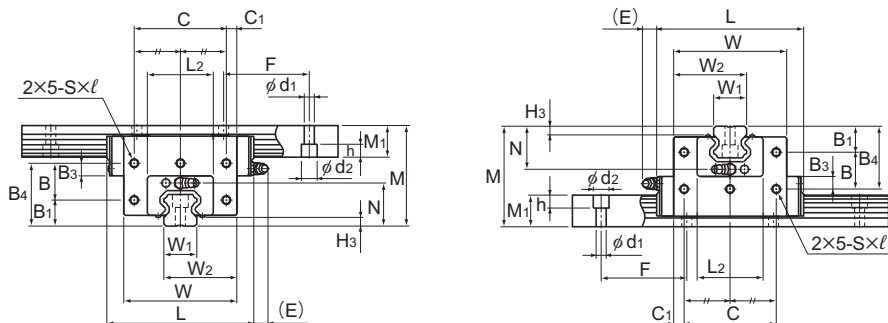

Models CSR20 to 45

Model No.	Outer dimensions			LM block dimensions												Grease nipple	H ₃
	Height	Width	Length	B ₁	B ₃	B ₄	B	C	C ₁	S × l	L ₂	H ₃	N	E			
	M	W	L														
CSR 15	47	38.8	56.6	—	11.3	34.8	—	20	9.4	M4 × 6	32	3.5	19.5	5.5	PB1021B	3.5	
CSR 20S CSR 20	57	50.8 66.8	74 90	— 13	13.3 7.8	42.5 37	— 24	30 56	10.4 5.4	M5 × 8	42	4	25	12	B-M6F	4	
CSR 25S CSR 25	70	59.5 78.6	83.1 102.2	— 18	17 9	52 44	— 26	34 64	12.75 7.3	M6 × 10	46	5.5	30	12	B-M6F	5.5	
CSR 30S CSR 30	82	70.4 93	98 120.6	— 21	20 12	61 53	— 32	40 76	15.2 8.5	M6 × 10	58	7	35	12	B-M6F	7	
CSR 35	95	105.8	134.8	24	14	61	37	90	7.9	M8 × 14	68	7.5	40	12	B-M6F	7.5	
CSR 45	118	129.8	170.8	30	16	75	45	110	9.9	M10 × 15	84	10	50	16	B-PT1/8	10	

Model number coding

4 CSR25 UU C0 +1200/1000L P

4	CSR25	UU	C0	+1200/1000L	P
Total No. of LM blocks	Model number	Contamination protection accessory symbol (*1)	LM rail length on the X axis (in mm)	LM rail length on the Y axis (in mm)	Accuracy symbol (*3) Precision grade (P)/Super precision grade (SP) Ultra precision grade (UP)
		Radial clearance symbol (*2) Normal (No symbol)/Light preload (C1) Medium preload (C0)			

(*1) See contamination protection accessory on **A1-496**. (*2) See **A1-71**. (*3) See **A1-79**.

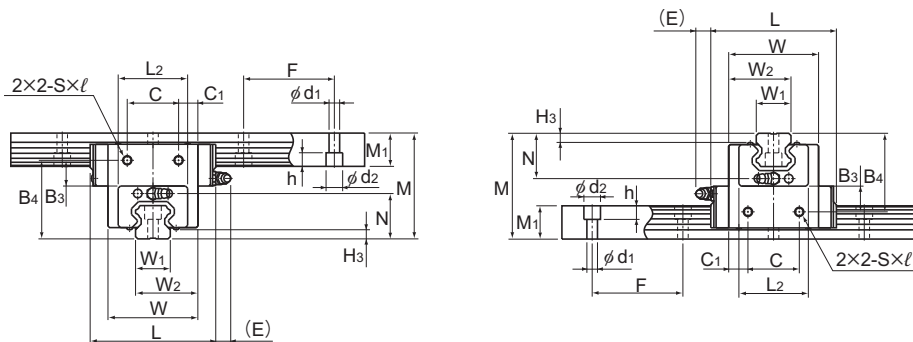

Models CSR15, 20S to 30S

Unit: mm

	LM rail dimensions						Basic load rating		Static permissible moment*		Mass	
	Width W_1 ± 0.05	W_2	Height M_1	Pitch F	$d_1 \times d_2 \times h$	Length* Max	C kN	C_0 kN	M_0 kN-m	M_B kN-m	LM block kg	LM rail kg/m
15	26.9	15	60	$4.5 \times 7.5 \times 5.3$	3000	8.33	13.5	0.0805	0.0805	0.34	1.5	
20	35.4 43.4	18	60	$6 \times 9.5 \times 8.5$	3000	13.8 21.3	23.8 31.8	0.19 0.27	0.19 0.323	0.73 1.3	2.3	
23	41.25 50.8	22	60	$7 \times 11 \times 9$	3000	19.9 27.2	34.4 45.9	0.307 0.459	0.307 0.529	1.2 2.2	3.3	
28	49.2 60.5	26	80	$9 \times 14 \times 12$	3000	28 37.3	46.8 62.5	0.524 0.751	0.524 0.889	2 3.6	4.8	
34	69.9	29	80	$9 \times 14 \times 12$	3000	50.2	81.5	1.2	1.32	5.3	6.6	
45	87.4	38	105	$14 \times 20 \times 17$	3090	80.4	127.5	2.43	2.44	9.8	11	

Note) The maximum length under "Length*" indicates the standard maximum length of an LM rail. (See **A1-298**.)
 Static permissible moment*: Static permissible moment value with 1 LM block

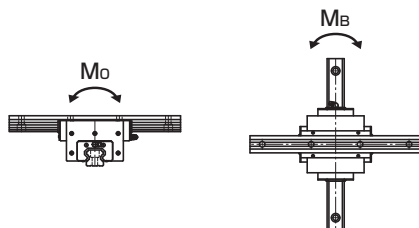

Standard Length and Maximum Length of the LM Rail

Table1 shows the standard lengths and the maximum lengths of model CSR variations. For the G dimension when a special length is required, we recommend selecting the corresponding G value from the table. The longer the G dimension is, the less stable the G area may become after installation, thus causing an adverse impact to accuracy.

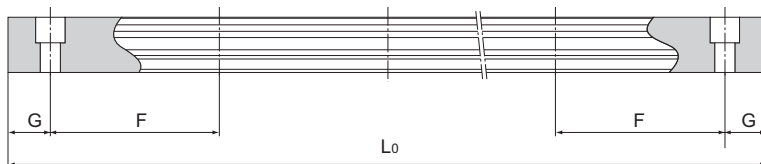

Table1 Standard Length and Maximum Length of the LM Rail for Model CSR

Unit: mm

Model No.	CSR 15	CSR 20	CSR 25	CSR 30	CSR 35	CSR 45
LM rail standard length (L ₀)	160	220	220	280	280	570
	220	280	280	360	360	675
	280	340	340	440	440	780
	340	400	400	520	520	885
	400	460	460	600	600	990
	460	520	520	680	680	1095
	520	580	580	760	760	1200
	580	640	640	840	840	1305
	640	700	700	920	920	1410
	700	760	760	1000	1000	1515
	760	820	820	1080	1080	1620
	820	940	940	1160	1160	1725
	940	1000	1000	1240	1240	1830
	1000	1060	1060	1320	1320	1935
	1060	1120	1120	1400	1400	2040
	1120	1180	1180	1480	1480	2145
	1180	1240	1240	1560	1560	2250
	1240	1360	1300	1640	1640	2355
	1360	1480	1360	1720	1720	2460
	1480	1600	1420	1800	1800	2565
	1600	1720	1480	1880	1880	2670
		1840	1540	1960	1960	2775
		1960	1600	2040	2040	2880
	2080	1720	2200	2200	2985	
	2200	1840	2360	2360	3090	
		1960	2520	2520		
		2080	2680	2680		
		2200	2840	2840		
		2320	3000	3000		
		2440				
Standard pitch F	60	60	60	80	80	105
G	20	20	20	20	20	22.5
Max length	3000	3000	3000	3000	3000	3090

Note) The maximum length varies with accuracy grades. Contact THK for details.

Tapped-hole LM Rail Type of Model CSR

The model CSR variations include a type with its LM rail bottom tapped. With the X-axis LM rail having tapped holes, this model can be secured with bolts from the top.

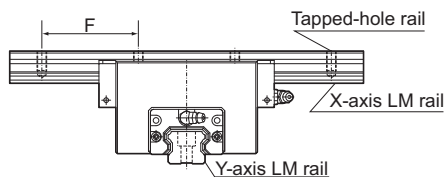

Table2 Dimensions of the LM Rail Tap Unit: mm

Model No.	S ₁	Effective tap depth l_1
15	M5	8
20	M6	10
25	M6	12
30	M8	15
35	M8	17
45	M12	24

Model number coding

4 CSR25 UU C0 +1200L P K/1000L P

Symbol for
tapped-hole LM rail type