

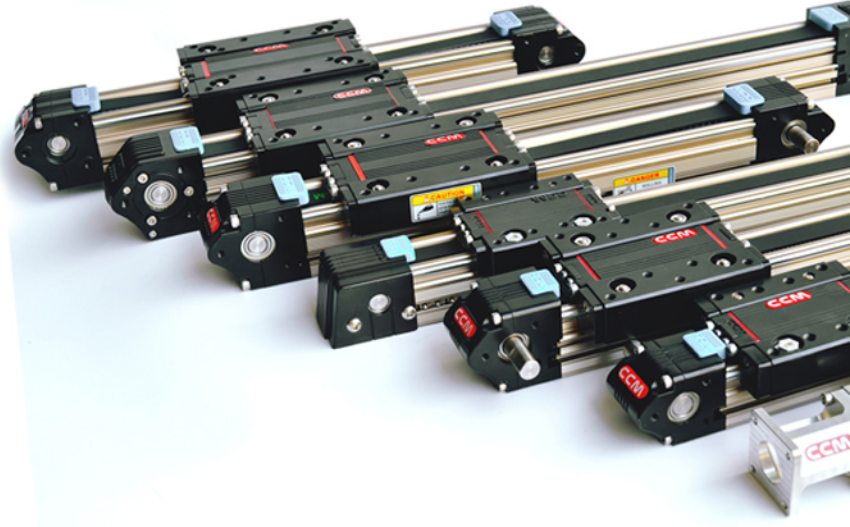

35 Years Experience | Low Noise Linear Module

PRODUCT CATALOG



CATALOGUE

Contents

◆ <b>Product overview</b>	<b>02.</b>
	Product overview
<i>W Series</i> .....	02
<i>H Series</i> .....	02
<i>S Series(Ball Screw)</i> .....	03
◆ <b>Product details</b>	<b>04.</b>
	Product details
<i>Model Numbers</i> .....	04
<i>W40-06</i> .....	06
<i>W45-15</i> .....	07
<i>W50-25</i> .....	08
<i>W60-35</i> .....	09
<i>H35-03</i> .....	10
<i>H80-40</i> .....	11
<i>H80-70</i> .....	12
◆ <b>Auxiliary Parts Introduction</b>	<b>13.</b>
	introduction
<i>Standard Mode</i> .....	13
<i>Speed Reducing Mode</i> .....	14
<i>Structure Connection Parts</i> .....	15
<i>Other Accessories</i> .....	16
◆ <b>Structure Introduction</b>	<b>17.</b>
	Structure introduction

# W Series

Linear Module



\* Customized length is available  
Various accessories for your option

Model	Max Load	Guide Width	Pitch	Torque	Positioning Repeatability	Jump for details
W40-06	6 KG	40 MM	75 MM	≤3 N.M	≤0.05 MM	<a href="#">Page6</a>
W45-15	15 KG	45 MM	75 MM	≤4.5 N.M	≤0.05 MM	<a href="#">Page7</a>
W50-25	25 KG	50 MM	95 MM	≤6.5 N.M	≤0.05 MM	<a href="#">Page8</a>
W60-35	30 KG	60 MM	95 MM	≤8.5 N.M	≤0.05 MM	<a href="#">Page9</a>

# H Series

Linear Module



\* Heavy-duty linear module

Model	H35-03	H80-40	H80-70
Max Load (KG)	3	40	50
Guide Width (MM)	35	80	80
Pitch (MM)	54	190	190
Torque (N.M)	≤3	≤13.5	≤13.5
Positioning Repeatability (MM)	≤0.05	≤0.05	≤0.05
Stroke (MM)	50~1250	50~5800	50~5730
Jump for details	<a href="#">Page10</a>	<a href="#">Page11</a>	<a href="#">Page12</a>

# S Series

## Ball Screw

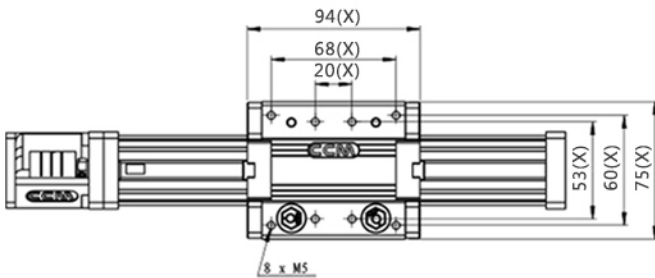
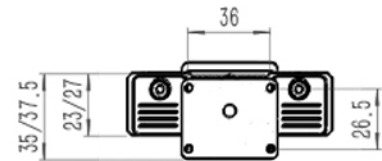
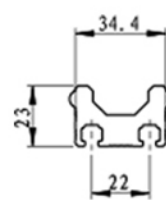
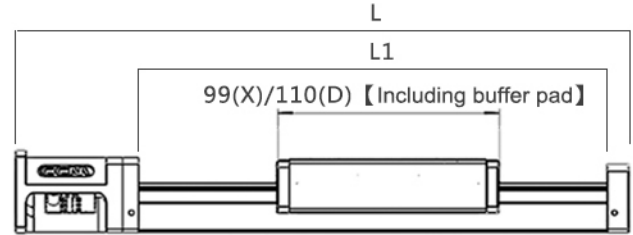

\* Carriage size ( X )

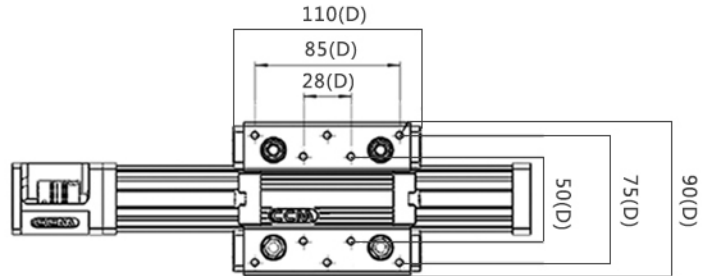

\* Carriage size ( D )

Model	Length		Weight (KG)	Rated Stroke length (mm)	Stroke length (mm)	Pitch (mm)	Linear accuracy (mm)	Rated Load (KG)	Applicable load (KG)	Torque (N.M)	Applicable Motor
	L	L1									
S35-50 ( X/D )	254.5	183	0.9	50	80	2.5	0.02	5	0-3	1	Nema 17 Stepper Motor
S35-100 ( X/D )	304.5	233	0.95	100	130	2.5	0.02	5	0-3	1	
S35-150 ( X/D )	354.5	283	1	150	180	2.5	0.02	5	0-3	1	
S35-200 ( X/D )	404.5	333	1.05	200	230	2.5	0.02	5	0-3	1	100W Servo Motor
S35-250 ( X/D )	454.5	383	1.1	250	280	2.5	0.02	5	0-3	1	
S35-300 ( X/D )	504.5	433	1.15	300	330	2.5	0.02	5	0-3	1	
Remark	1.Rail mount,coupler are available 3.Stepper motor and drive are available			2.S series ball screw includes aluminum profile,carriage and motor bracket							

# Product details



## Model Numbers

**CCM – W40-10 – L1000 – DC – 1A – 400W(D14)**

①

②

③

④

⑤

⑥

- ① Brand,Model : CCM-W40-10/W45-15/W50-25 ...
- ② Total length : L1000 ( Total length 1000mm ) ;  
GL1000 ( Rail length 1000mm ) ;  
S1000 ( Stroke length 1000mm ) ;
- ③ Motor connections : DC ( Direct connection ) ;  
DG ( Connect by speed redacer set )  
\* For mounting way,please see below pictures
- ④ Shaft position : 1~8 ( Shaft position ) ; A~D ( Motor Position )  
\* For mounting way,please see below pictures
- ⑤ Motor Model
- ⑥ Motor shaft Dia

# Motor connections

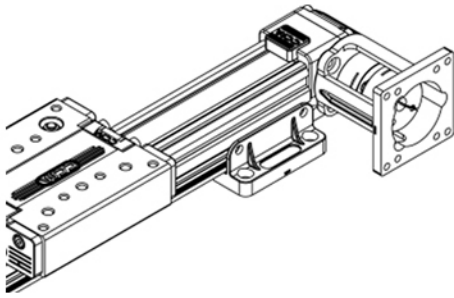

Motor Bracket

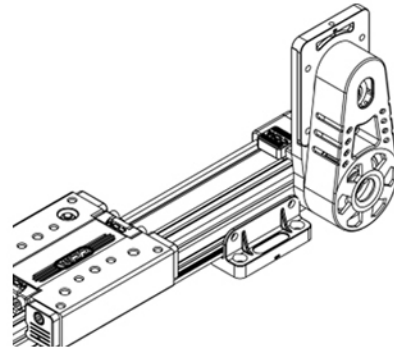

Speed Reducer set

# Part length indication

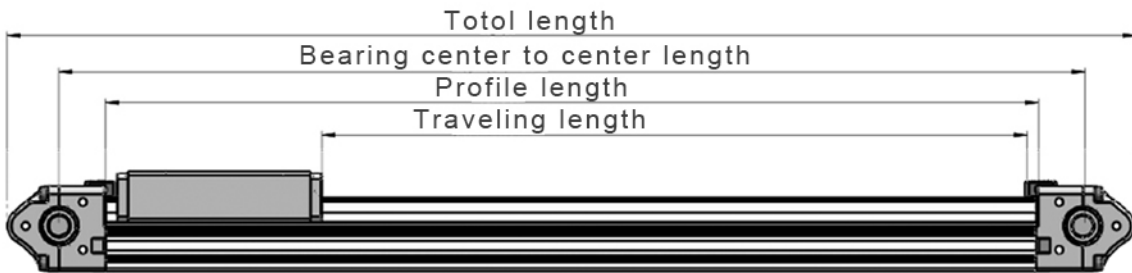

# Shaft position

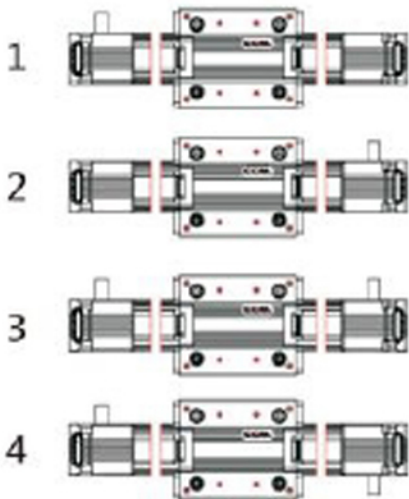

Shaft position

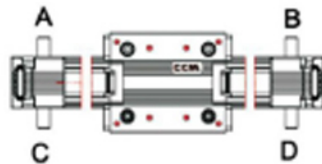

Motor position

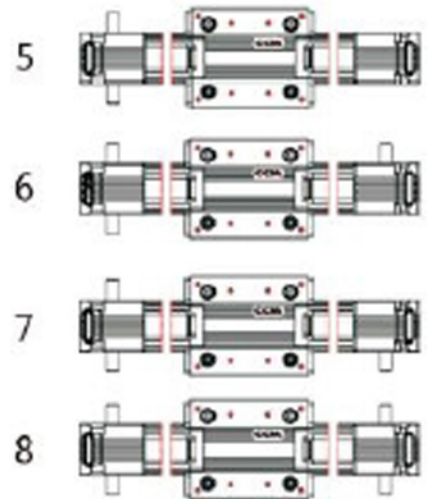

Shaft position

# W40-06 | Linear Module

## Parameters

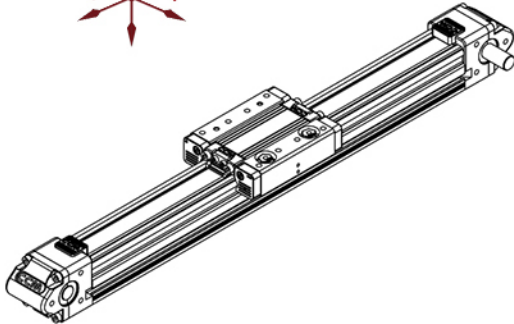
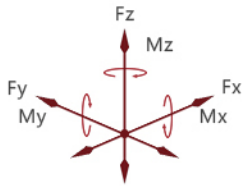

Model		W40-06
Carriage parameter	F <sub>xmax</sub> (N)	200
	F <sub>ymax</sub> (N)	70
	F <sub>zmax</sub> (N)	56
	M <sub>xmax</sub> (N.M)	2.1
	M <sub>ymax</sub> (N.M)	3.1
	M <sub>zmax</sub> (N.M)	3.1
$\text{Max Load factor} = \frac{F_y}{F_{y\max}} + \frac{F_z}{F_{z\max}} + \frac{M_x}{M_{x\max}} + \frac{M_y}{M_{y\max}} + \frac{M_z}{M_{z\max}} \leq 1.2$		

- Model : W40-06
- Speed : 0-4 M/s
- Applicable Motor and Mounting Way :
- Guide Width : 40 mm
- Customized length : Up to 4 meters
- Stepper Motor : NEMA 17
- Max Load : 6 KG
- Input Torque : ≤ 3 N.M
- NEMA 23;
- Pitch : 75 mm
- Belt spec. : Stainless steel PU-3M-15
- Servo Motor :
- Bearing spec. : HTD3M-25Z
- Straightness : ±0.03/300 mm
- 100W(Direct connection)
- 200W/400W(DC/Speed redcer set)

## Dimensions

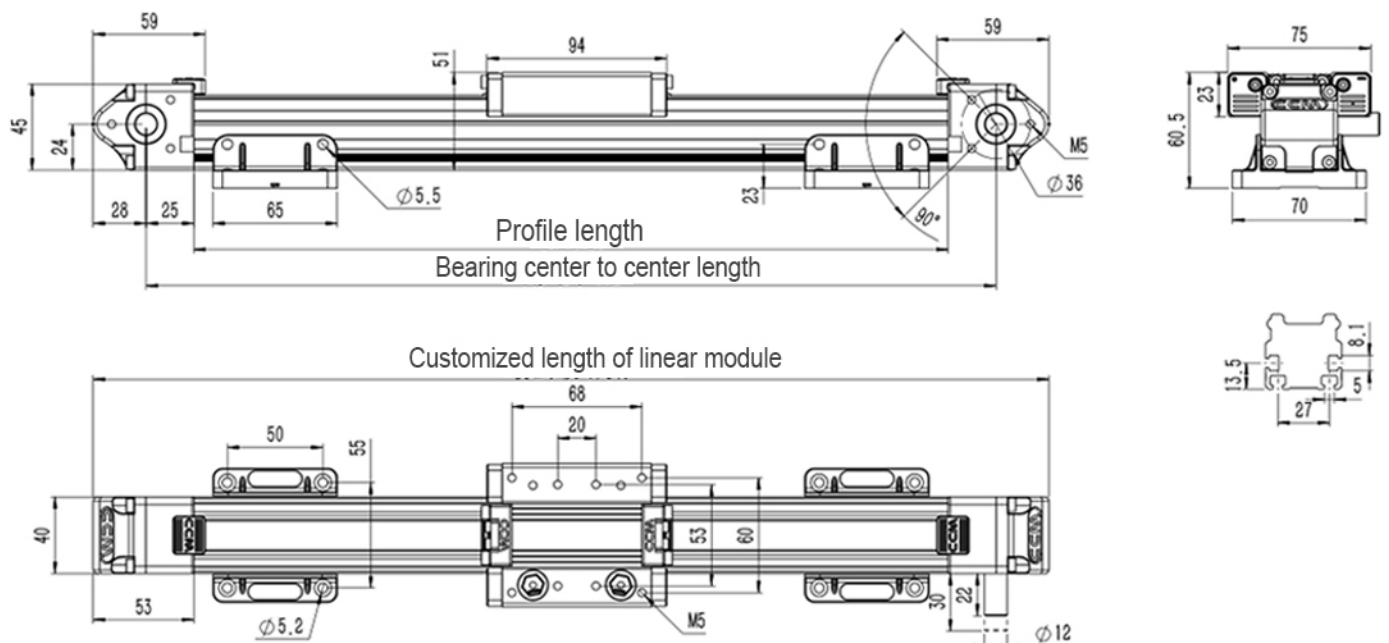

# W45-15 | Linear Module

## Parameters

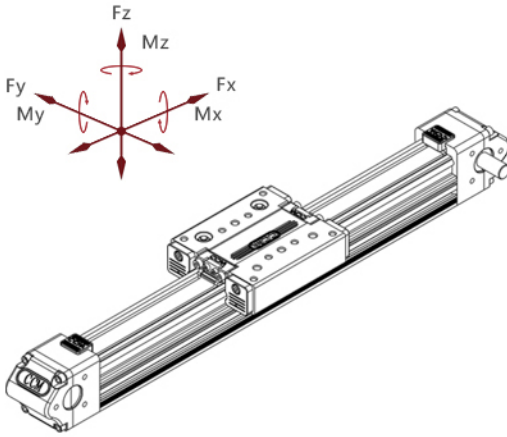

Model		W45-15
Carriage parameter	F <sub>xmax</sub> (N)	200
	F <sub>ymax</sub> (N)	150
	F <sub>zmax</sub> (N)	120
	M <sub>xmax</sub> (N.M)	4.4
	M <sub>ymax</sub> (N.M)	7.8
	M <sub>zmax</sub> (N.M)	8.4
$\text{Max Load factor} = \frac{F_y}{F_{y\max}} + \frac{F_z}{F_{z\max}} + \frac{M_x}{M_{x\max}} + \frac{M_y}{M_{y\max}} + \frac{M_z}{M_{z\max}} \leq 1.2$		

- Model : W45-15
- Speed : 0-4 M/s
- Applicable Motor and Mounting Way :
- Guide Width : 45 mm
- Customized length : Up to 6 meters
- Stepper Motor : NEMA 17
- Max Load : 15 KG
- Input Torque : ≤ 4.5 N.M
- NEMA 23;
- Pitch : 75 mm
- Belt spec. : Stainless steel PU-3M-15
- Servo Motor :
- Bearing spec. : HTD3M-25Z
- Straightness : ±0.03/300 mm
- 100W(Direct connection)
- 200W/400W(DC/Speed redcer set)

## Dimensions

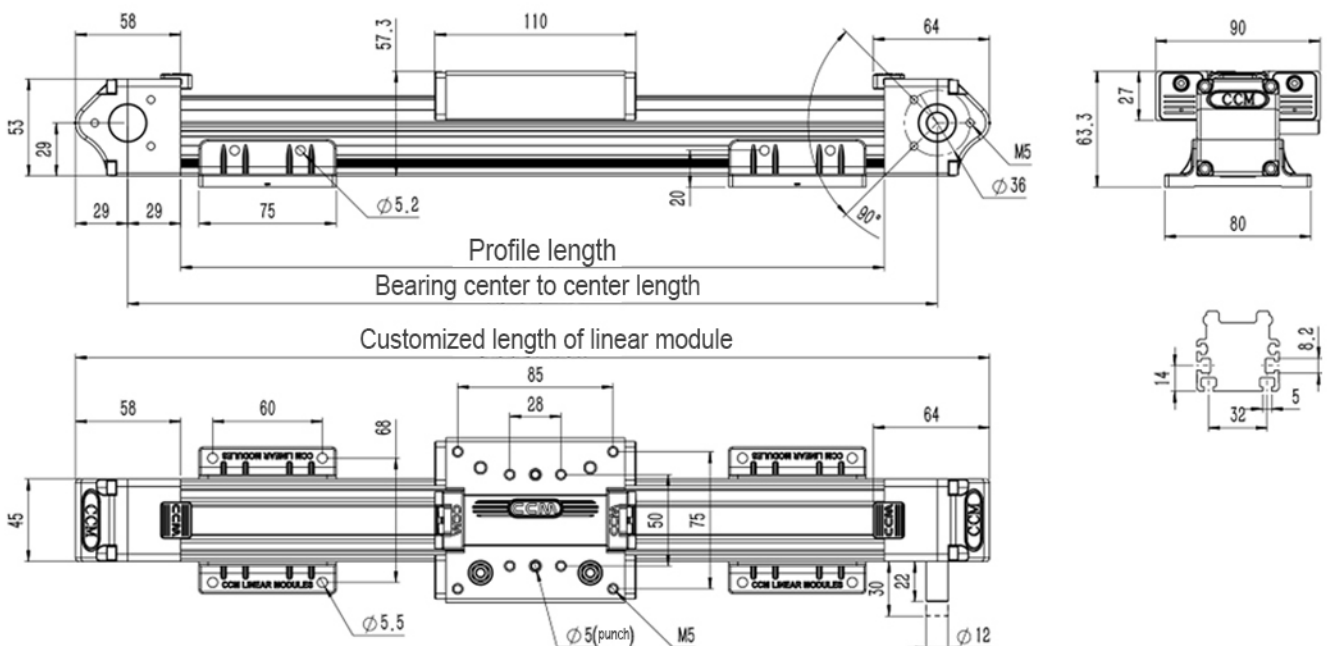

# W50-25 | Linear Module

## Parameters

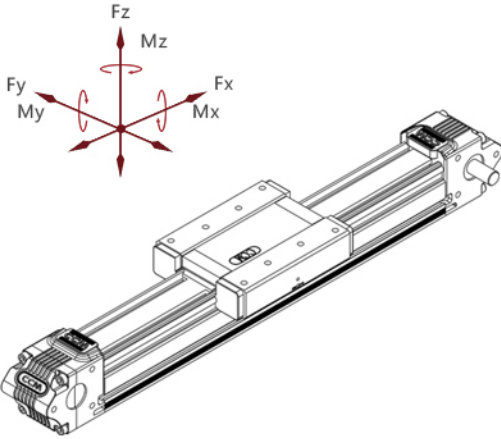

Model		W50-25
Carriage parameter	F <sub>xmax</sub> (N)	515
	F <sub>ymax</sub> (N)	250
	F <sub>zmax</sub> (N)	200
	M <sub>xmax</sub> (N.M)	9.2
	M <sub>ymax</sub> (N.M)	16
	M <sub>zmax</sub> (N.M)	18
$\text{Max Load factor} = \frac{F_y}{F_{y\max}} + \frac{F_z}{F_{z\max}} + \frac{M_x}{M_{x\max}} + \frac{M_y}{M_{y\max}} + \frac{M_z}{M_{z\max}} \leq 1.2$		

- Model : W50-25
- Guide Width : 50 mm
- Max Load : 25 KG
- Pitch : 95 mm
- Bearing spec. : STD5M-19Z
- Speed : 0-4 M/s
- Customized length : Up to 6 meters
- Input Torque : ≤ 6.5 N.M
- Belt spec. : Stainless steel PU-5M-20
- Straightness : ±0.03/300 mm
- Applicable Motor and Mounting Way :  
 Stepper Motor : NEMA 23  
 NEMA 34;  
 Servo Motor :  
 750W(Direct connection)  
 200W/400W(DC/Speed redcer set)

## Dimensions

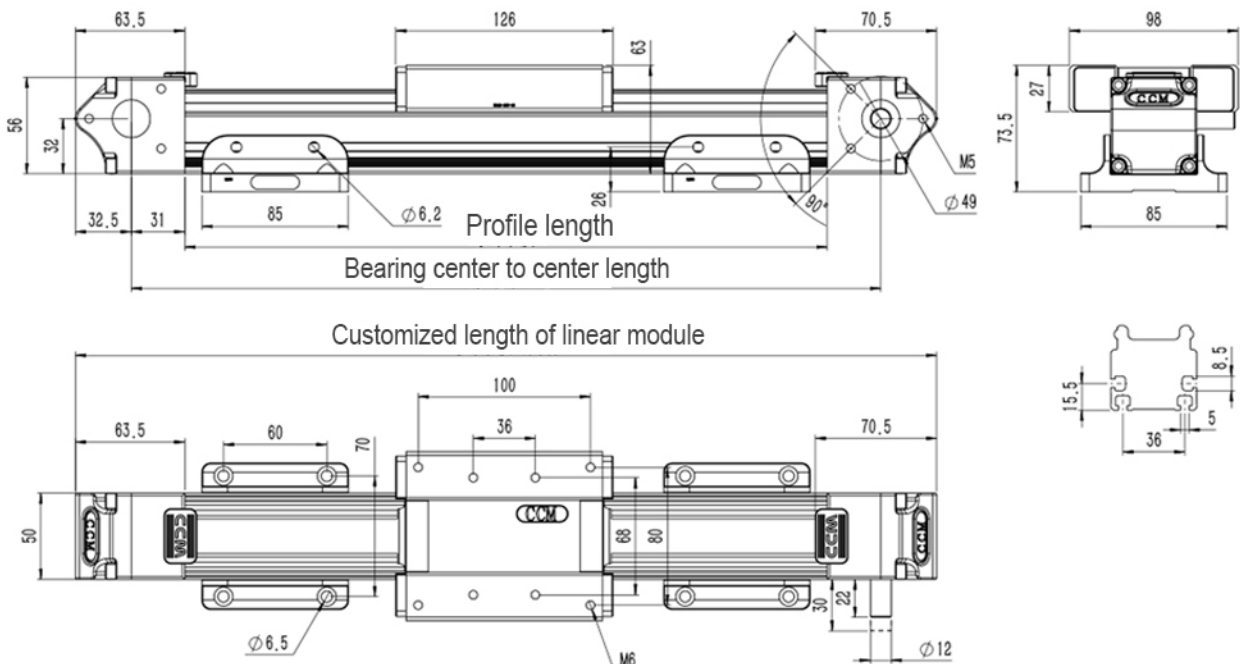



# W60-35 | Linear Module

## Parameters

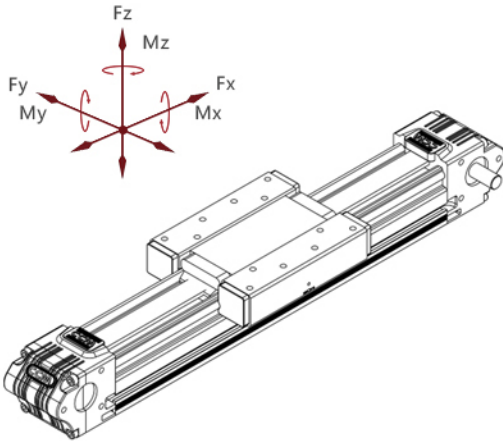

Model		W60-35
Carriage parameter	Fxmax(N)	515
	Fymax(N)	350
	Fzmax(N)	280
	Mxmax(N.M)	15.4
	Mymax(N.M)	26.6
	Mzmax(N.M)	30.8

$$Max\ Load\ factor = \frac{Fy}{Fymax} + \frac{Fz}{Fzmax} + \frac{Mx}{Mxmax} + \frac{My}{Mymax} + \frac{Mz}{Mzmax} \leq 1.2$$

- Model : W60-35
- Guide Width : 60 mm
- Max Load : 35 KG
- Pitch : 95 mm
- Bearing spec. : STD5M-19Z
- Speed : 0-4 M/s
- Customized length : Up to 6 meters
- Input Torque :  $\leq 8.5$  N.M
- Belt spec. : Stainless steel PU-5M-20
- Straightness :  $\pm 0.03/300$  mm
- Applicable Motor and Mounting Way :
  - Stepper Motor : NEMA 23
  - NEMA 34;
  - Servo Motor :
    - 750W(Direct connection)
    - 200W/400W(DC/Speed redcer set)

## Dimensions

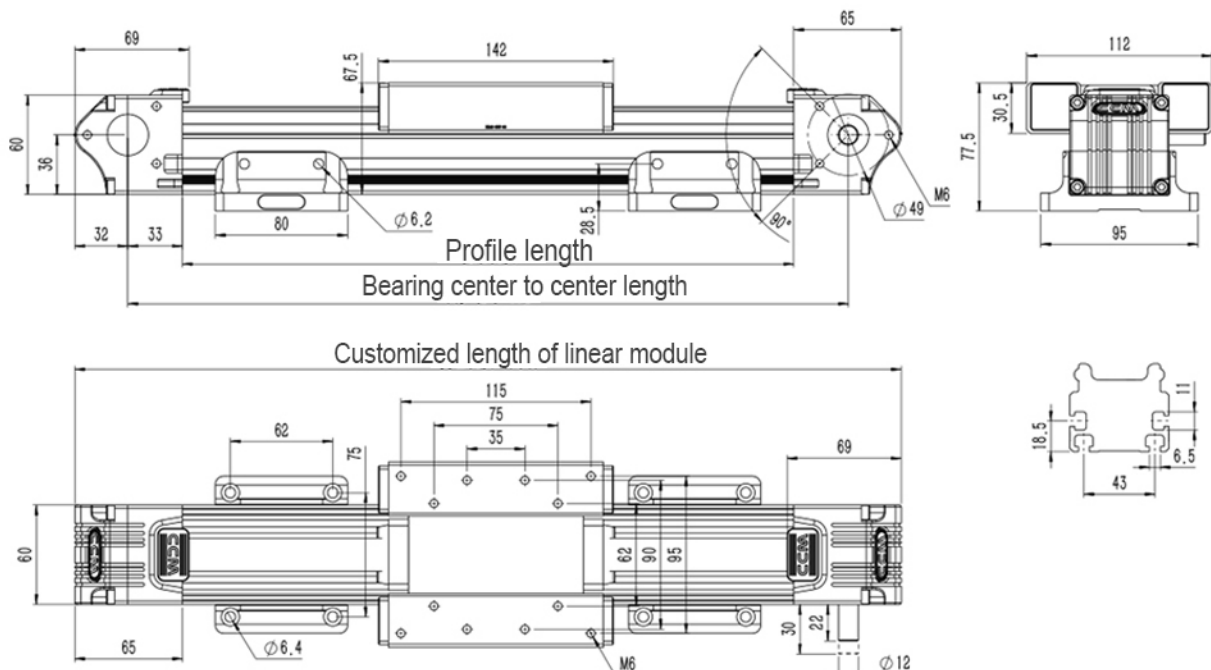

## Parameters

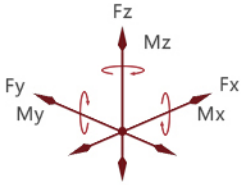

Model		H35
Carriage parameter	F <sub>xmax</sub> (N)	100
	F <sub>ymax</sub> (N)	30
	F <sub>zmax</sub> (N)	24
	M <sub>xmax</sub> (N.M)	1.48
	M <sub>ymax</sub> (N.M)	2.2
	M <sub>zmax</sub> (N.M)	2.2
$\text{Max Load factor} = \frac{F_y}{F_{y\max}} + \frac{F_z}{F_{z\max}} + \frac{M_x}{M_{x\max}} + \frac{M_y}{M_{y\max}} + \frac{M_z}{M_{z\max}} \leq 1.2$		

- Model : H35
- Guide Width : 35 mm
- Max Load : 3 KG
- Pitch : 54 mm
- Bearing spec. : HTD3M-16Z
- Speed : 0-3 M/s
- Customized length : Up to 1.5 meters
- Input Torque : ≤ 3 N.M
- Belt spec. : Stainless steel PU-3M-08
- Straightness : ±0.03/300 mm
- Applicable Motor and Mounting Way :  
Stepper Motor : NEMA 17

## Dimensions

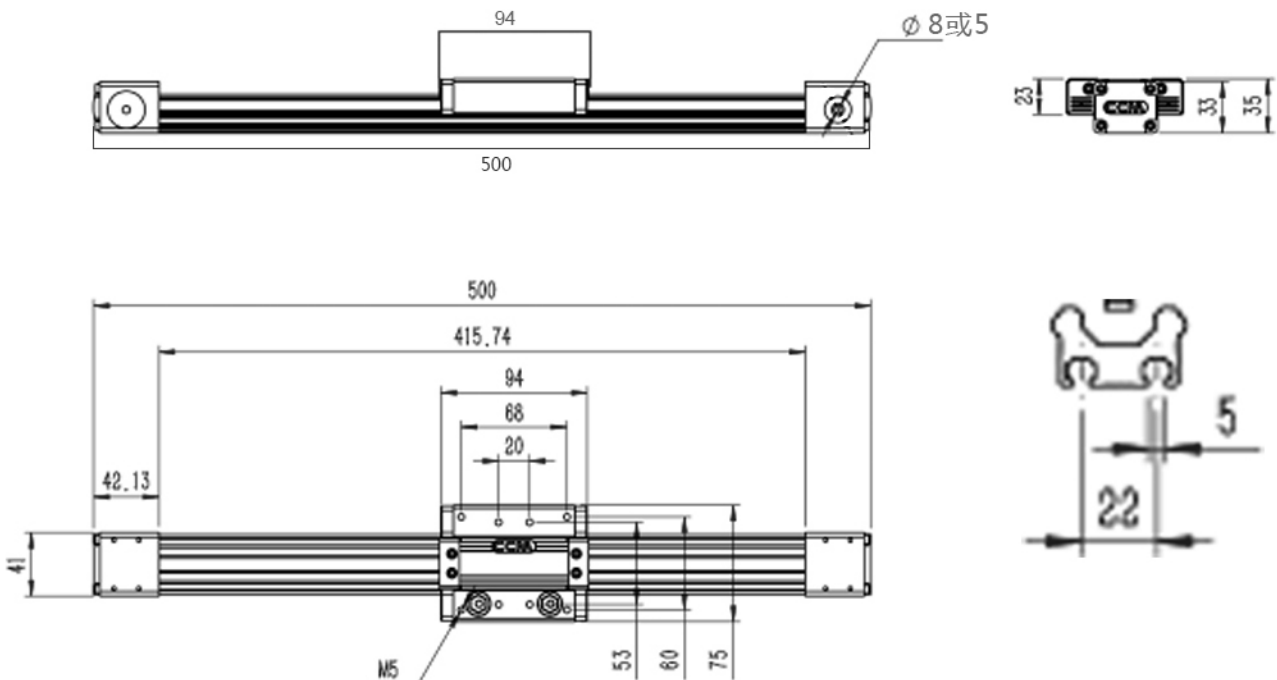

## Parameters

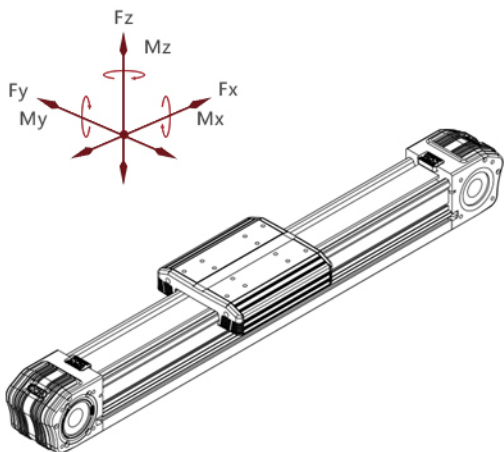

Model		H80-40
Carriage parameter	F <sub>xmax</sub> (N)	700
	F <sub>ymax</sub> (N)	700
	F <sub>zmax</sub> (N)	560
	M <sub>xmax</sub> (N.M)	42
	M <sub>ymax</sub> (N.M)	47.6
	M <sub>zmax</sub> (N.M)	61.6
$\text{Max Load factor} = \frac{F_y}{F_{y\max}} + \frac{F_z}{F_{z\max}} + \frac{M_x}{M_{x\max}} + \frac{M_y}{M_{y\max}} + \frac{M_z}{M_{z\max}} \leq 1.2$		

- Model : H80-40
- Speed : 0-4 M/s
- Applicable Motor and Mounting Way :
- Guide Width : 80 mm
- Customized length : Up to 6 meters
- Stepper Motor : NEMA 34
- Max Load : 40 KG
- Input Torque : ≤13.5 N.M
- NEMA 42;
- Pitch : 190 mm
- Belt spec. : Stainless steel PU-5M-33
- Servo Motor :
- Bearing spec. : STD5M-38Z
- Straightness : ±0.03/300 mm
- 400W/750W/1000W/1500W  
(Direct Connection)

## Dimensions

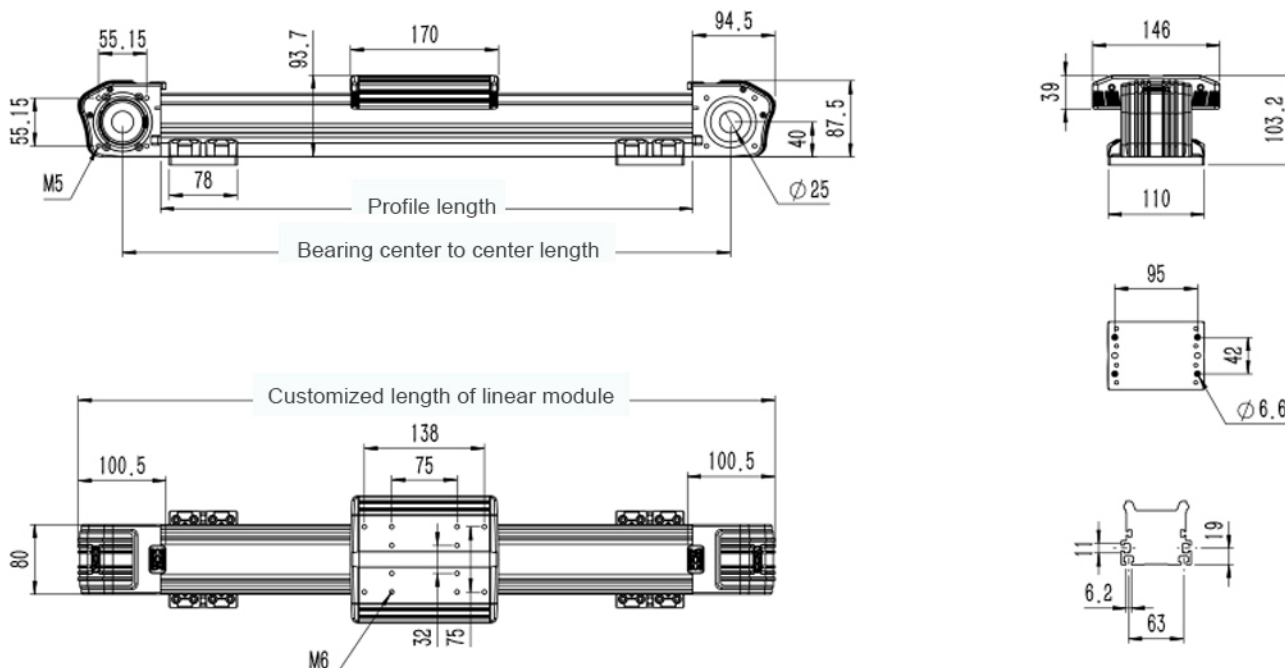

# H80-70 | Linear Module

## Parameters

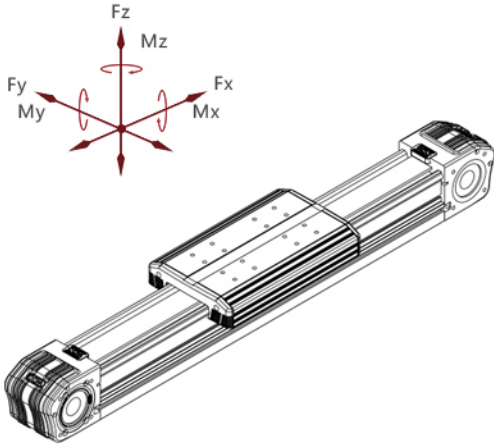

型号	H80-70	
滑块 标定 载荷	F <sub>xmax</sub> (N)	700
	F <sub>ymax</sub> (N)	700
	F <sub>zmax</sub> (N)	560
	M <sub>xmax</sub> (N.M)	42
	M <sub>ymax</sub> (N.M)	71.4
	M <sub>zmax</sub> (N.M)	92.4
最大负载系数 = $\frac{F_y}{F_{y\max}} + \frac{F_z}{F_{z\max}} + \frac{M_x}{M_{x\max}} + \frac{M_y}{M_{y\max}} + \frac{M_z}{M_{z\max}} \leq 1.2$		

- Model : H80-70
- Guide Width : 80 mm
- Max Load : 50 KG
- Pitch : 190 mm
- Bearing spec. : STD5M-38Z
- Speed : 0-4 M/s
- Customized length : Up to 6 meters
- Input Torque : ≤ 8.5 N.M
- Belt spec. : Stainless steel PU-5M-33
- Straightness : ±0.03/300 mm
- Applicable Motor and Mounting Way :
  - Stepper Motor : NEMA 34  
NEMA 42;
  - Servo Motor : 400W/750W/1000W/1500W  
(Direct Connection)

## Dimensions

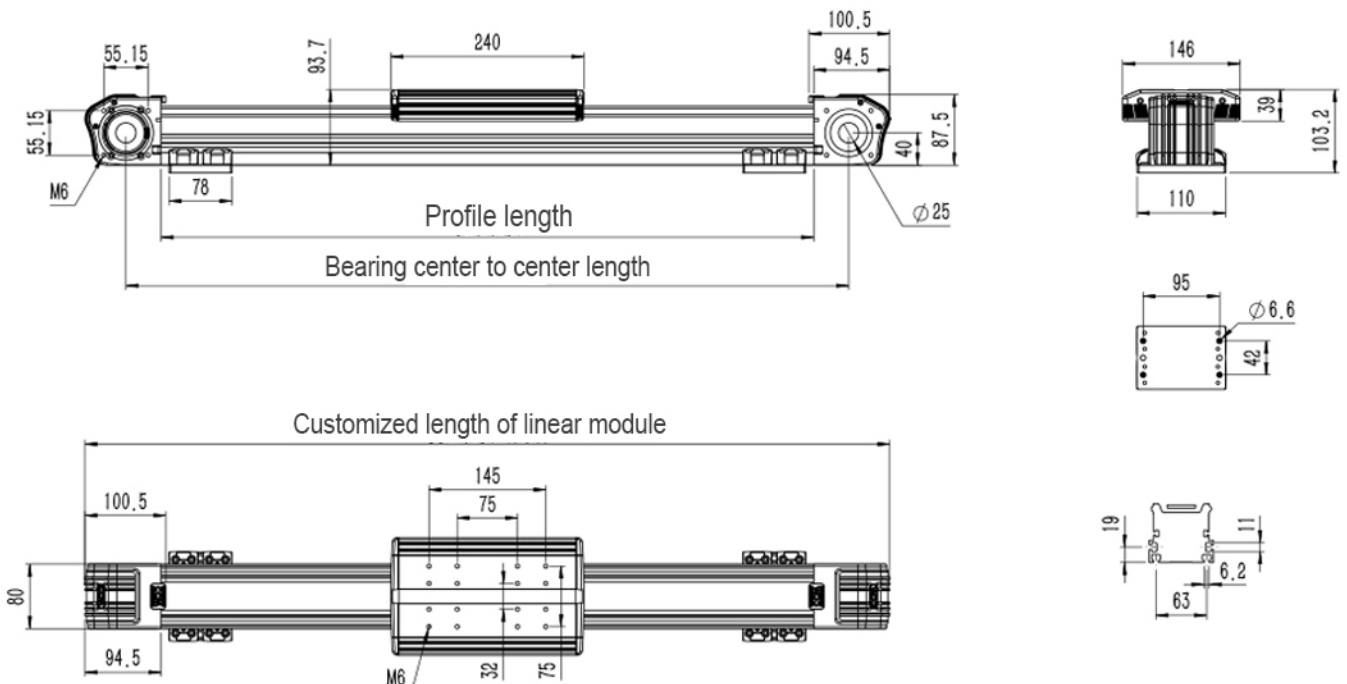

# Auxiliary Parts | Standard Mode

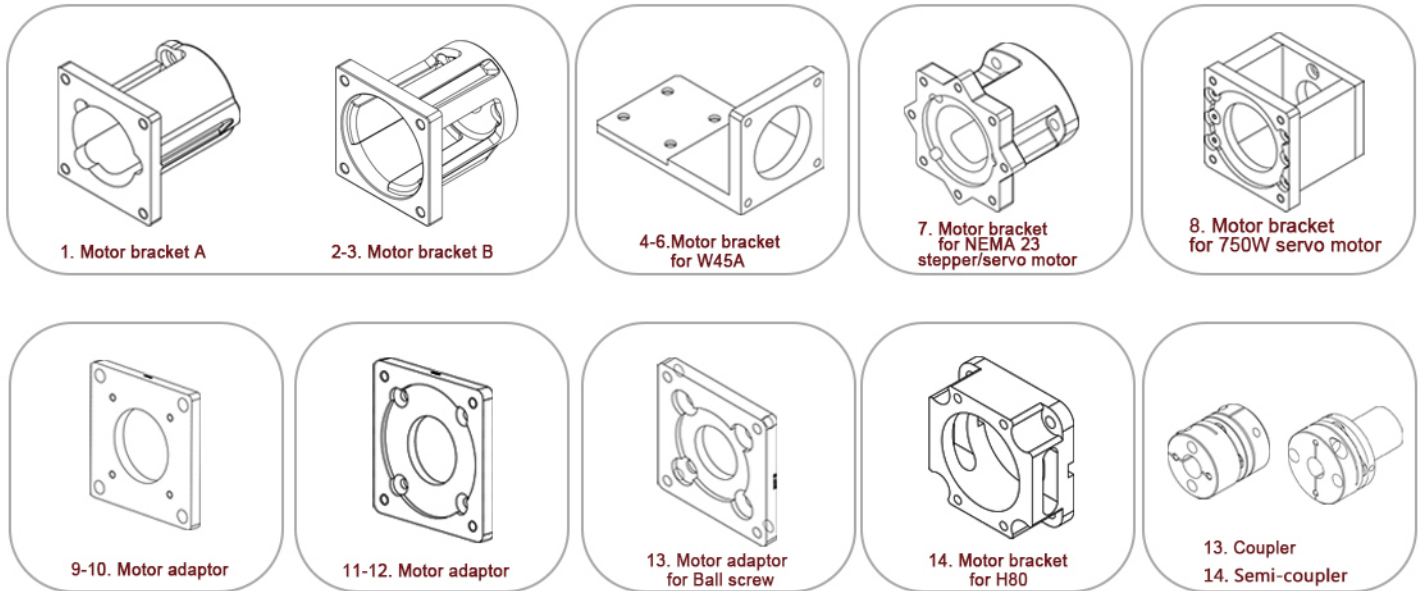

Name	Model No.	Applicable linear motion rail	Applicable Motor
1.Motor bracket A for NEMA 23 stepper motor	57-W4045	W40 W45	NEMA 23 stepper motor
2.Motor bracket B for NEMA 23 stepper motor	42-W45A	W45A	NEMA 24 stepper motor
3.Motor bracket B for 200w/400w servo motor	57-W45A	W45A	200w/400w servo motor
4.Motor bracket for NEMA 17 stepper motor	60-W45A	W45A	NEMA 17 stepper motor
5.Motor bracket for NEMA 23 stepper motor	57/60-W50	W50/W60	NEMA 23 stepper motor
6.Motor bracket for 400w servo motor	400w-W5060	W50 W60	400w servo motor
7.Motor bracket for NEMA 23 stepper motor /400w servo motor	57/60-W5060	W50 W60	NEMA 23 stepper motor / 400w servo motor
8.Motor bracket for 750w servo motor	750w-W5060	W50 W60	750w servo motor
9.Motor adaptor for NEMA 17 stepper motor	NEMA 17	W40 W45 W50 W60	NEMA 17 stepper motor
10.Motor adaptor for 100w servo motor	100w servo motor	W40 W45 W50 W60	100w servo motor
11.Motor adaptor for 200w/400w servo motor	200w/400w servo motor		200w/400w servo motor
12.Motor adaptor for NEMA 34 stepper motor	NEMA 34		NEMA 34 stepper motor
13.Ball screw motor adaptor for NEAM 23 strpper motor	NEMA 23	S35	
14.Motor bracket for H80		H80	NEMA 34 strpper motor 400w/750w/1500w servo motor
15.Coupler	12-6.35/8/10/11/12/12.7/14/15/16/19/20		
16.Semi-coupler	Inner Diameter 12.7/14/19/20		

# Auxiliary Parts

## Standard Reducing Mode



Name	Model No.	Applicable linear motion rail	Applicable Motor
1.Speed reducer set	W4045-57 <i>i</i> =1:2.5 (20:50, B12, 249)	W40 W45	NEMA 23 stepper motor
2.Speed reducer set	W4045-60 <i>i</i> =1:2 (25:50, B12, 255)	W40 W45	200w/400w servo motor
3.Speed reducer set	(Post position)57 <i>i</i> =1:1.9 (20:38, B10, 228)	W45A	NEMA 23 stepper motor
4.Speed reducer set	(Under position)57 <i>i</i> =1:1.9 (20:38, B10, 228)	W45A	NEMA 23 stepper motor
5.Speed reducer set	W50-57 <i>i</i> =1:2.5 (20:50, B12, 249)	W50	NEMA 23 stepper motor
6.Speed reducer set	W60-57 <i>i</i> =1:2.5 (20:50, B12, 249)	W60	NEMA 23 stepper motor
7.Speed reducer set	W50-60 <i>i</i> =1:2 (30:60, B15, 276)	W50	200w/400w servo motor
8.Speed reducer set	W60-60 <i>i</i> =1:2 (30:60, B15, 276)	W60	200w/400w servo motor
9.Speed reducer set	W50-86 <i>i</i> =1:2 (30:60, B15, 312)	W50	NEMA 34 stepper motor
10.Speed reducer set	W60-86 <i>i</i> =1:2 (30:60, B15, 312)	W60	NEMA 34 stepper motor
11.Central speed reducer set for Y axis	NEMA 23 stepper <i>i</i> =1:2.5 (20:50, B12, 237)	W Series	NEMA 23 stepper motor
12.Central speed reducer set for Y axis	400w servo <i>i</i> =1:2 (25:50, B12, 243)	W Series	200w/400w servo motor
13.Central speed reducer set for Y axis	NEMA 34 stepper <i>i</i> =1:3 (24:72, B15)	W Series	NEMA 34 stepper motor

# Auxiliary Parts

## XYZ Axis' connetors

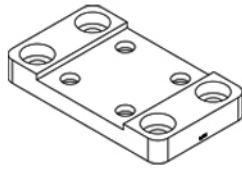

1. H35 Rail Mount

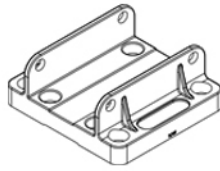

W40/50/60 Rail Mount

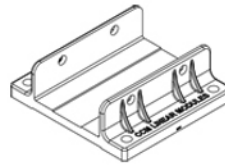

W45 Rail Mount

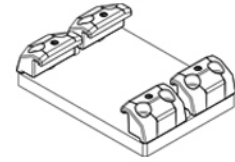

2. H80 Rail Mount

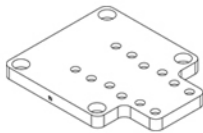

3-6.T shape connector

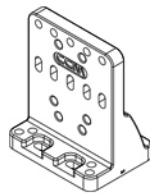

7. Multi-L shape connector

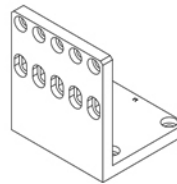

8-9.L shape connector

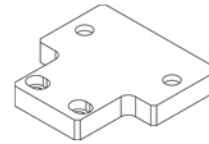

10. Aluminum profile connector

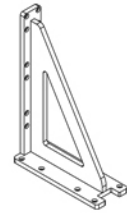

11-13.Tripod

Name	Model No.	Applicable Linear Module
1.Rail Mount	H35	H35
	W40	W40-10
	W45	W45/W40-10
	W50	W50
	W60	W60
2.Rail mount set	1 pcs oblong rail mount+4 pcs auxiliary parts	H80
3.T shape connector-1		W40-06 W45A
4.T shape connector-2		W45-15
5.T shape connector-3		W50-25
6.T shape connector-4		W60-35
7.Multi-L shape connector-1		W40 W45
8.L shape connector-3		W50-25
9.L shape connector-4		W60-35
10.Aluminum profile F shape connector		W40/W45
11.Tripod-1		W45-15
12.Tripod-2		W50
13.Tripod-3		W60

# Auxiliary Parts | Other Accessories



1. Magnetic Limit Sensor

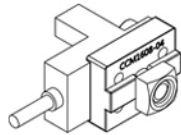

2. Optical Limit Sensor

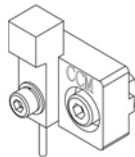

3. H80 Limit Sensor

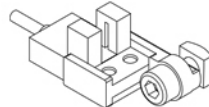

4. Optical Limit Sensor for horizontal mount

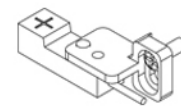

5. S-Limit Sensor

Name	Model No.	Applicable Linear Module
1. Magnetic Limit Sensor		W Series/H Series
2. Optical Limit Sensor		W Series/H Series
3. H80 Limit Sensor		H80
4. Optical Limit Sensor for horizontal mount		H Series
5. S-Limit Sensor		S Series
6. Rod	D=12mm/14mm/19mm	
7. CO2 laser kit	Single/Double laser head	W40 W45
8. Stepper motor + driver	Leadshine ( For details, please contact us )	
9. Servo motor + driver	Delta/Panasonic ( For details, please contact us )	
10. Planetary Gearbox	( For details, please contact us )	



# Common structures and configurations

## 1. Single Slider Linear Module

- CCM Standard Module \* 1
- Carriage\*1 • Rail Mount\*2
- Standard Mode: Motor Mount/Bracket \*1 ,Coupler \*1  
(Speed Reducing Mode:Speed Reducer Set \*1)

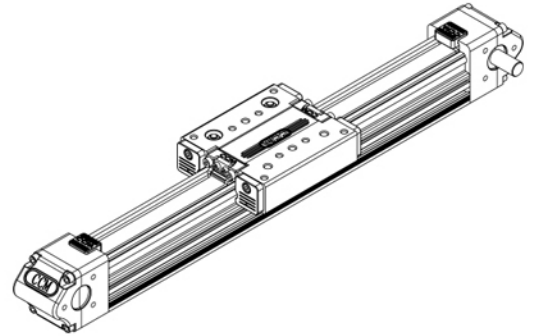

## 2. Double Sliders Linear Module

- CCM Standard Module \* 1
- Carriage\*2 • Rail Mount\*2
- Standard Mode: Motor Mount/Bracket \*1 ,Coupler \*1  
(Speed Reducing Mode:Speed Reducer Set \*1)

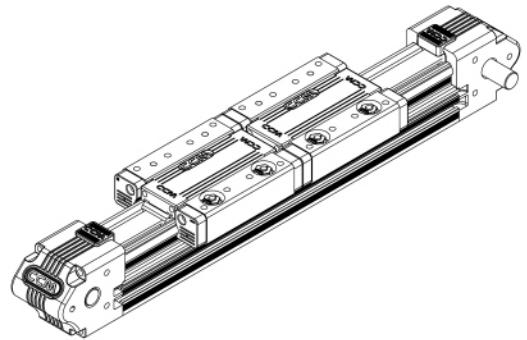

## 3. Parallel Axis Linear Module

- CCM Standard Module \* 1
- Carriage\*2 • Rail Mount\*4
- Rod-D12mm\*1 • Coupler 12-12\*2
- Standard Mode: Motor Mount/Bracket \*1 ,Coupler \*1  
(Speed Reducing Mode:Speed Reducer Set \*1)

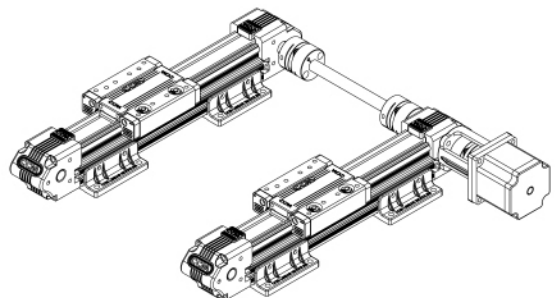

#### 4. Double Carriages Parallel Axis Linear Module

- CCM Standard Module \* 2
- Carriage\*2    • Rail Mount\*4
- Rod-D12mm\* 1    • Coupler 12-12\* 2
- Extra Carriage\* 2
- Standard Mode: Motor Mount/Bracket \*1 ,Coupler \*1  
(Speed Reducing Mode:Speed Reducer Set \*1)

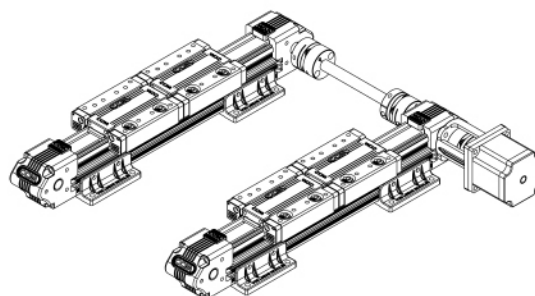

#### 5. Compact Parallel Axis Linear Module

- CCM Standard Module \* 2
- Carriage\*2    • Rail Mount\*4
- Rod-D12mm\* 1
- Standard Mode: Motor Mount/Bracket \*1 ,Coupler \*1  
(Speed Reducing Mode:Speed Reducer Set \*1)

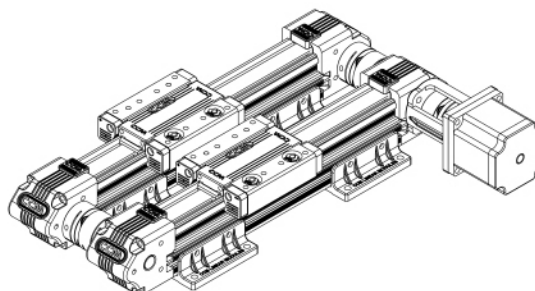

#### 6. Two-axis Linear Stage

- CCM Standard Module \* 2
- Carriage\*2    • Rail Mount\*2
- T-shape connector \* 1
- Standard Mode: Motor Mount/Bracket \*2 ,Coupler \*2  
(Speed Reducing Mode:Speed Reducer Set \*2)

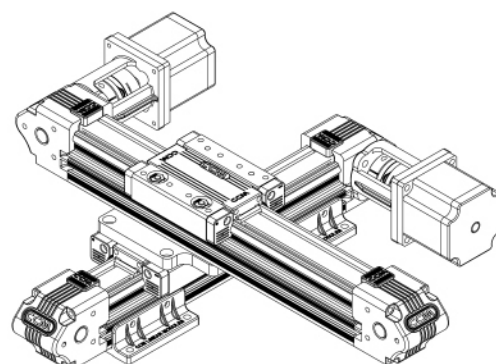

## 7.Two-axis Linear Stage

- CCM Standard Module \* 2
- Carrige\*2 • Rail Mount\*2
- L-shape connector\*1
- Standard Mode: Motor Mount/Bracket \*2 ,Coupler \*2  
(Speed Reducing Mode:Speed Reducer Set \*2)

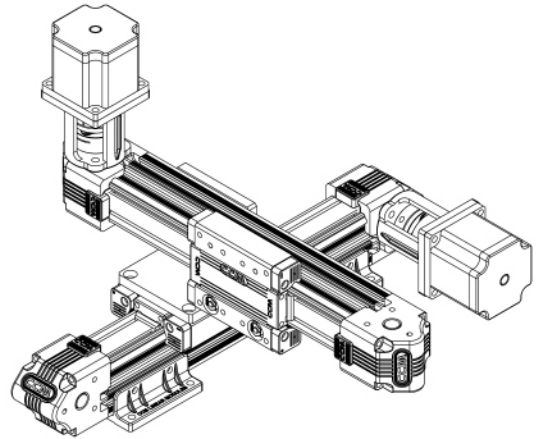

## 8.XY Linear Stage

- CCM Standard Module \* 3
- Carrige\*3 • Rail Mount\*4
- Rod-D12mm\*1 • Coupler\*2
- T-shape connector\*2
- Standard Mode: Motor Mount/Bracket \*2 ,Coupler \*2  
(Speed Reducing Mode:Speed Reducer Set \*2)

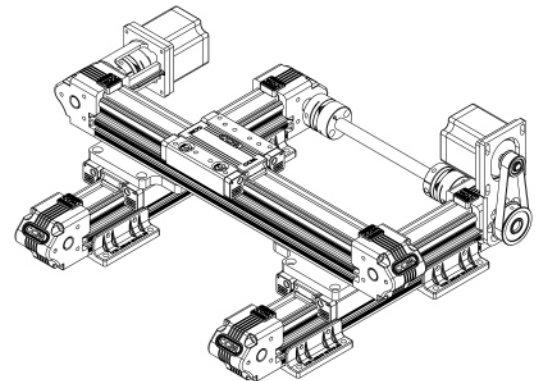

## 9.Double sliders on X axis

- CCM Standard Module \* 3
- Carrige\*3 • Rail Mount\*4
- Rod-D12mm\*1 • Coupler\*2
- T-shape connector\*2 • Extra Carrige\*1
- Standard Mode: Motor Mount/Bracket \*2 ,Coupler \*2  
(Speed Reducing Mode:Speed Reducer Set \*2)

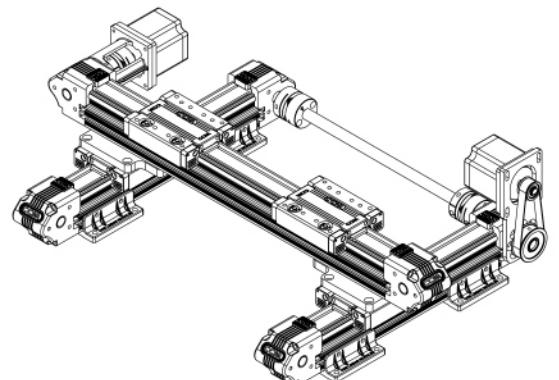

## 10.XY Linear Stage

- CCM Standard Module \* 3
- Carrige\*3 • Rail Mount\*4
- Rod-D12mm\*1 • Coupler\*2
- L-shape connector\*2
- Standard Mode: Motor Mount/Bracket \*2 ,Coupler \*2  
(Speed Reducing Mode:Speed Reducer Set \*2)

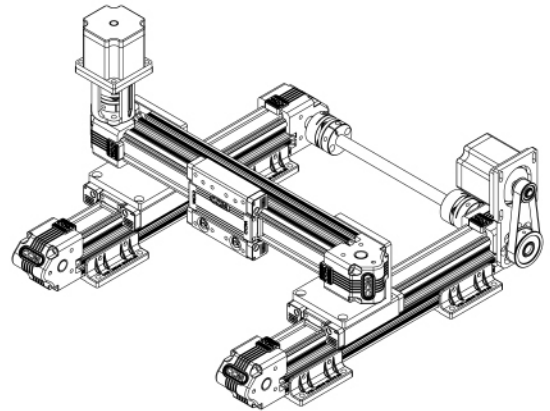

## 11.XYZ Gantry system

- CCM Standard Module \* 4
- Carrige\*4 • Rail Mount\*4
- L-shape connector\*2 • T-shape connector\*1
- Rod-D12mm\*1 • Coupler\*2
- Standard Mode: Motor Mount/Bracket \*3 ,Coupler \*3  
(Speed Reducing Mode:Speed Reducer Set \*3)

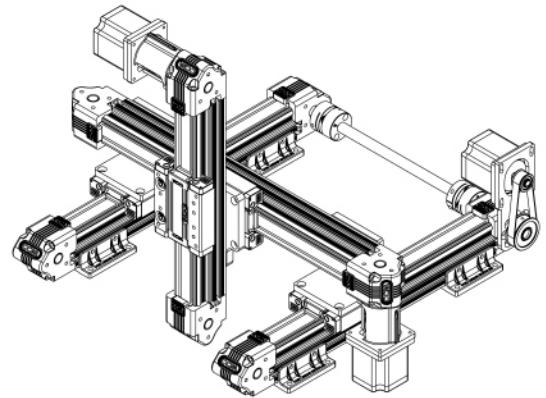

## 12.XYY Linear Stage

- CCM Standard Module \* 3
- Carrige\*4 • Rail Mount\*4
- T-shape connector\* 2 • Coupler\*1
- Standard Mode: Motor Mount/Bracket \*2 ,Coupler \*2  
(Speed Reducing Mode:Speed Reducer Set \*2)

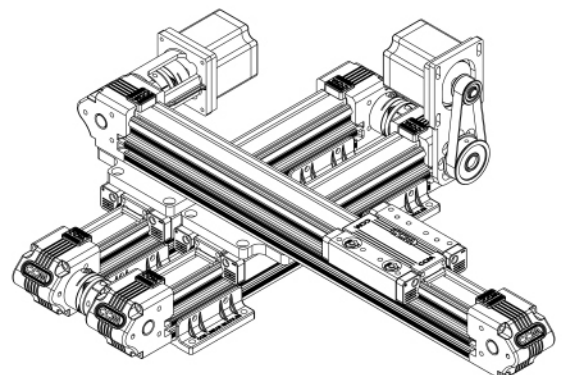

### 13.XYY Linear Stage

- CCM Standard Module \* 3
- Carrige\*4 • Rail Mount\*4
- L-shape connector\*2 • Coupler\*1
- Standard Mode: Motor Mount/Bracket \*2 ,Coupler \*2  
(Speed Reducing Mode:Speed Reducer Set \*2)

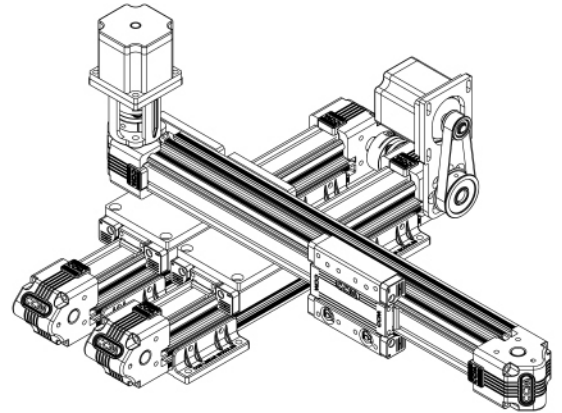

### 14.XYZ Linear Stage

- CCM Standard Module \* 4
- Carrige\*4 • Rail Mount\*4
- L-shape connector\*2 • T-shape connector\*1
- Coupler\*1
- Standard Mode: Motor Mount/Bracket \*3 ,Coupler \*3  
(Speed Reducing Mode:Speed Reducer Set \*3)

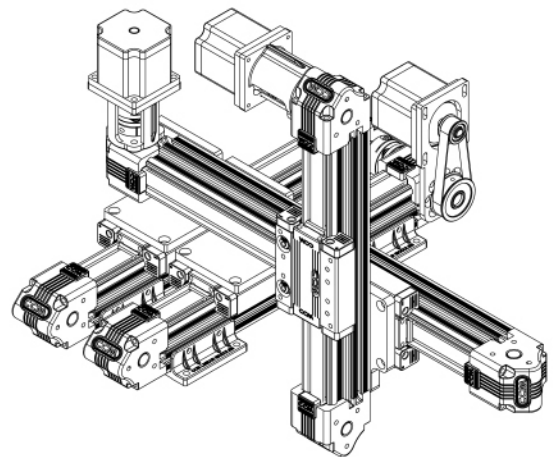

### 15.XYY Linear Stage

- CCM Standard Module \* 3
- Carrige\*4 • Rail Mount\*4
- T-shape connector\*2
- Coupler\*4 • Rod-D12mm\*2
- Standard Mode: Motor Mount/Bracket \*2 ,Coupler \*2  
(Speed Reducing Mode:Speed Reducer Set \*2)

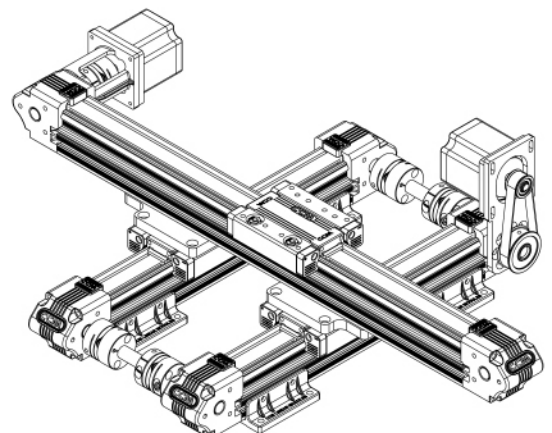

## 16.XYY Linear Stage

- CCM Standard Module \* 3
- Carrige\*4 • Rail Mount\*4
- L-shape connector\*2
- Rod-D12mm\*2 • Coupler\*4
- Standard Mode: Motor Mount/Bracket \*2 ,Coupler \*2  
(Speed Reducing Mode:Speed Reducer Set \*2)

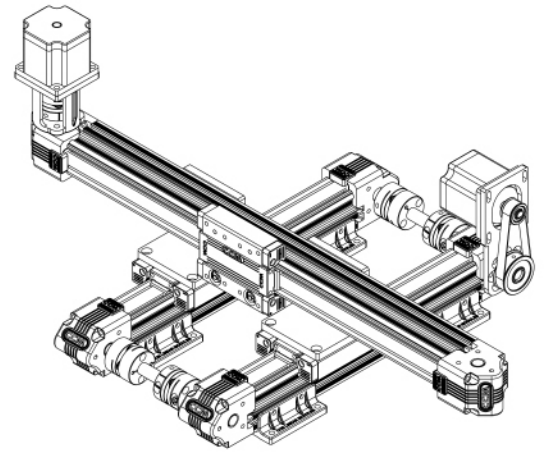

## 17.XZ Cartesion Arm

- CCM Standard Module \* 2
- Carrige\*2 • Rail Mount\*2
- Tripod \* 1 • Extra carrige \* 1
- Standard Mode: Motor Mount/Bracket \*2 ,Coupler \*2  
(Speed Reducing Mode:Speed Reducer Set \*2)

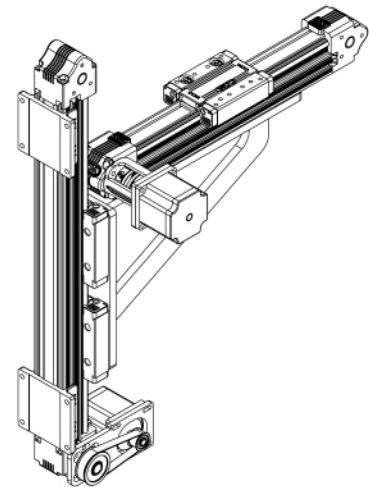

## 18.XXYY Linear Stage

- CCM Standard Module \* 4
- Carrige\*4 • Rail Mount\*4
- T-shape connector\*4
- Rod-D12mm\*2 • Coupler\*4
- Extra Carrige\*2
- Standard Mode: Motor Mount/Bracket \*2 ,Coupler \*2  
(Speed Reducing Mode:Speed Reducer Set \*2)

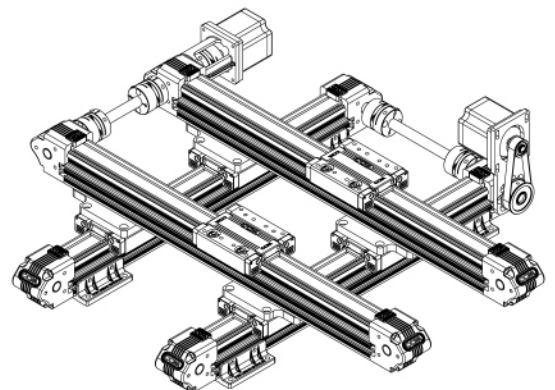

## 19. Double slider on X axis

- CCM Standard Module \* 4
- Carrige\*4 • Rail Mount\*4
- T-shape connector\*4
- Rod-D12mm\*2 • Coupler\*4
- Extra Carrige\*4
- Standard Mode: Motor Mount/Bracket \*2 ,Coupler \*2  
(Speed Reducing Mode:Speed Reducer Set \*2)

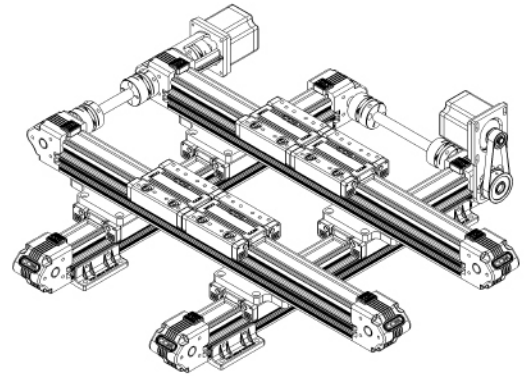

## 20.XYZ Gantry Robot

- CCM Standard Module \* 4
- Carrige\*5 • Rail Mount\*4
- T-shape connector\*2 • Tripod \* 2
- Rod-D12mm\*2 • Coupler\*4
- Extra Carrige\*2
- Standard Mode: Motor Mount/Bracket \*3 ,Coupler \*3  
(Speed Reducing Mode:Speed Reducer Set \*3)

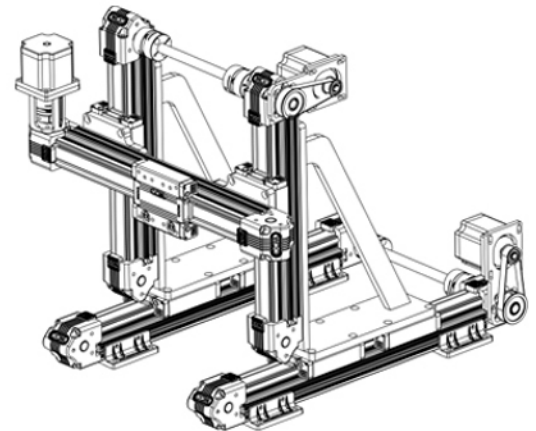

## 21.XYZ Gantry Robot

- CCM Standard Module \* 5
- Carrige\*5 • Rail Mount\*4
- T-shape connector\*2 • Tripod \* 2
- Rod-D12mm\*1 • Coupler\*4
- Extra Carrige\*2
- Standard Mode: Motor Mount/Bracket \*3 ,Coupler \*3  
(Speed Reducing Mode:Speed Reducer Set \*3)

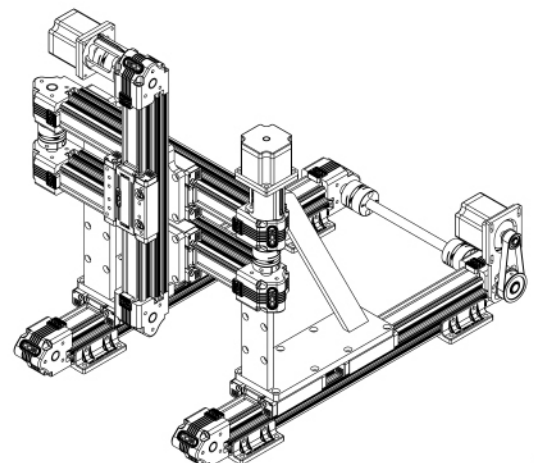

## 22.XYZ Linear Stage

- CCM Standard Module \* 4
- Carrige\*4 • Rail Mount\*4
- T-shape connector\*1 • Tripod \* 2
- Rod-D12mm\*1 • Coupler\*2
- Extra Carrige\*2
- Standard Mode: Motor Mount/Bracket \*3 ,Coupler \*3  
(Speed Reducing Mode:Speed Reducer Set \*3)

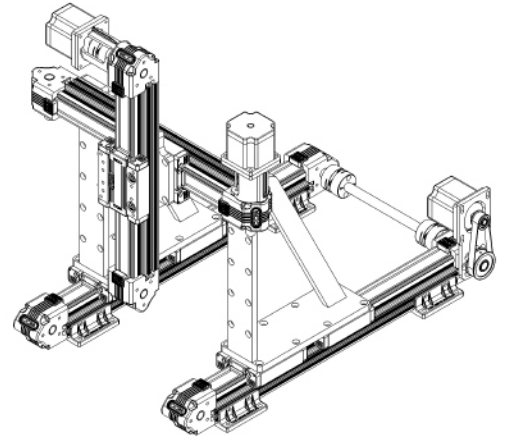

## 23.XYZ Linear Stage

- CCM Standard Module \* 3
- Carrige\*3 • Rail Mount\*4
- Tripod \* 2 • Extra Carrige\*2
- Rod-D12mm\*1 • Coupler\*2
- Standard Mode: Motor Mount/Bracket \*2 ,Coupler \*2  
(Speed Reducing Mode:Speed Reducer Set \*2)

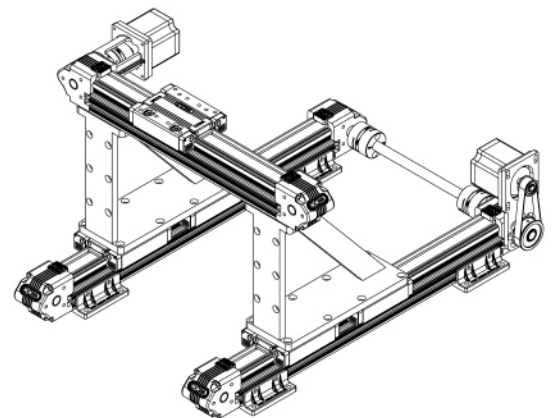

## 24.Z axis:ball screw

- CCM Standard Module \* 3 • CCM Ball Screw S35 \* 1
- Carrige\*4 • Rail Mount\*4
- L-shape connector\*2
- Rod-D12mm\*1 • Coupler\*2
- S35 Connector(suitable for W40-10/W45-15/W50-20)\*1
- Standard Mode: Motor Mount/Bracket \*3 ,Coupler \*3  
(Speed Reducing Mode:Speed Reducer Set \*3)

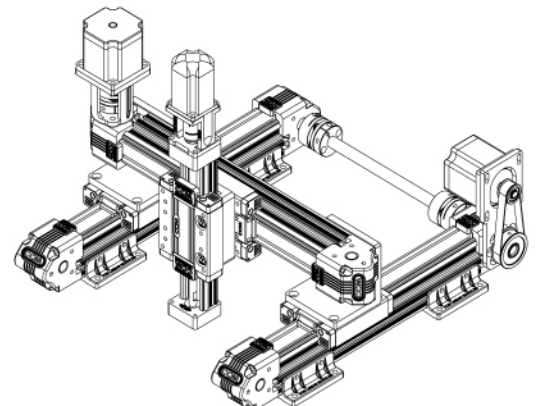



## 25. Aluminum Frame XYZ Linear Stage

- CCM Standard Module \* 3
- Customized T-Shape Connector\*4
- T-Shape Connector\*1
- Aluminum Frame\*1
- Standard Mode: Motor Mount/Bracket \*3 ,Coupler \*3  
(Speed Reducing Mode:Speed Reducer Set \*3)

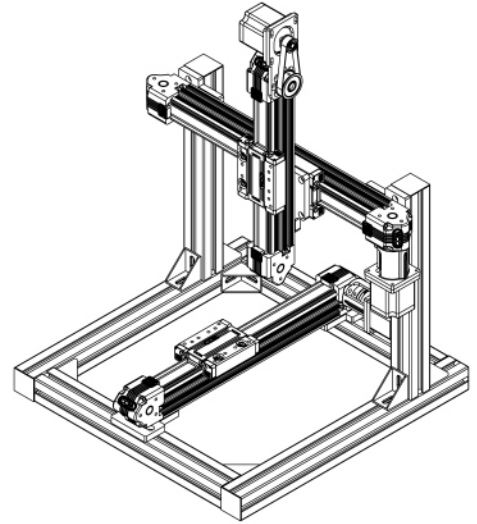

---

## 26. Aluminum Fram XYZ Linear Stage

- CCM Standard Module \* 4
- Customized T-Shape Connector\*2
- T-Shape Connector\*2      • Z Axis Mount\*6
- Rod-D12mm\*1      Coupler\*2
- Aluminum Frame\*1
- Standard Mode: Motor Mount/Bracket \*2 ,Coupler \*2  
(Speed Reducing Mode:Speed Reducer Set \*3)

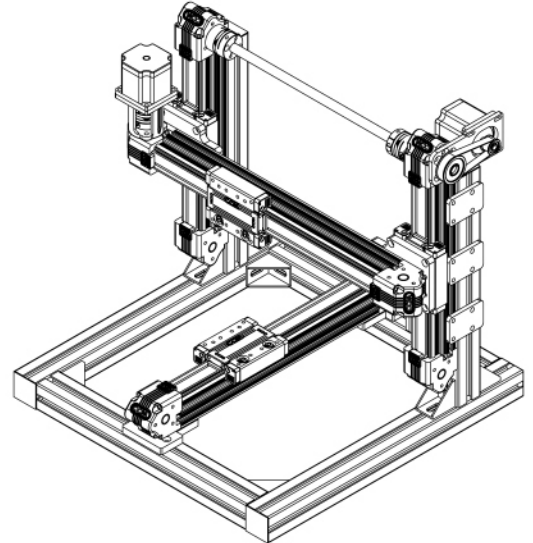

◆ For customized length and structure, please contact us.