

# **TRACKER**

**SAFE**

**OWNER USE  
AND  
CARE MANUAL**

**SPS-B  
(3 ADMIN)**

**Tracker Safe LLC**  
6317 NE 63rd Street  
Vancouver, WA 98661  
(360) 213-0363  
[www.TrackerSafe.com](http://www.TrackerSafe.com)

## TABLE OF CONTENTS

What's Included with Your Safe.....	Page 2
Safe Identification.....	Page 3
Opening your Safe for the First Time.....	Page 4
Fingerprint Registration.....	Page 5
Enrolling Administrator Fingerprints.....	Page 6
Enrolling User Fingerprints.....	Page 7
Opening the Safe After Setup.....	Page 7
Locking the Safe.....	Page 7
Trouble Enrolling Fingerprints.....	Page 8
Deleting Fingerprints.....	Page 8
Sound ON / OFF.....	Page 8
Changing the Batteries.....	Page 8
Security Cable & Elastic Strap .....	Page 9
Warranty.....	Page 10
Warranty Registration Form.....	Page 11

## WHAT'S INCLUDED WITH YOUR SAFE

- (Qty 1) Security Cable
- (Qty 1) Elastic Strap
- (Qty 2) Keys

Fill this out for future reference.

*(Do not store manual in the safe)*

Serial Number:

---

Key Number: *(if applicable)*

---

Combination:

---

Original Receipt: *(Attach Here)*

**Tracker Safe LLC**  
6317 NE 63rd Street  
Vancouver, WA 98661  
(360) 213-0363  
[www.TrackerSafe.com](http://www.TrackerSafe.com)

## OPENING YOUR SAFE FOR THE FIRST TIME

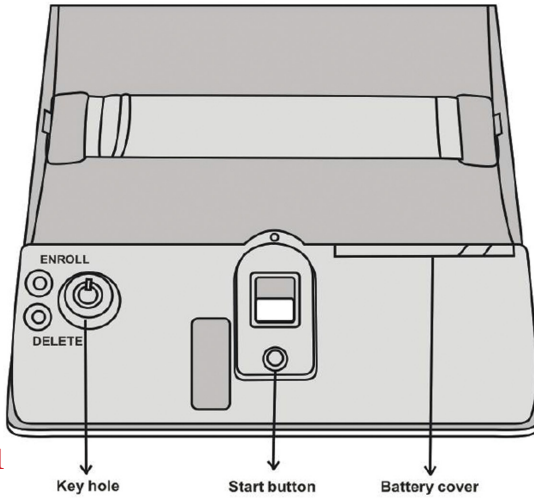

Figure 1

- 1) Locate the supplied keys from the packaging and set the safe on a flat surface.
  - 2) Insert the key into the lock and turn the key clockwise (to the right) until you hear a click (about a quarter turn). (See Figure 1)
  - 3) Remove the key by turning it counter-clockwise (to the left).
  - 4) Once the key is removed, you may lift the lid completely open.
  - 5) The battery compartment is located inside the safe on the right. Gently slide the cover up and remove it from the interior.  
(See Figure 2 on page 5)
  - 6) Pull on the ribbon to remove the battery holder. Insert four (4) AA **alkaline** batteries with a “use date” of at least five (5) years in the future. Be mindful of the battery orientation.
- (Recommended battery brands: Duracell™, Energizer™, Eveready™)*
- 7) Insert the battery holder into the battery compartment.
  - 8) Re-install the battery cover and slide it closed.

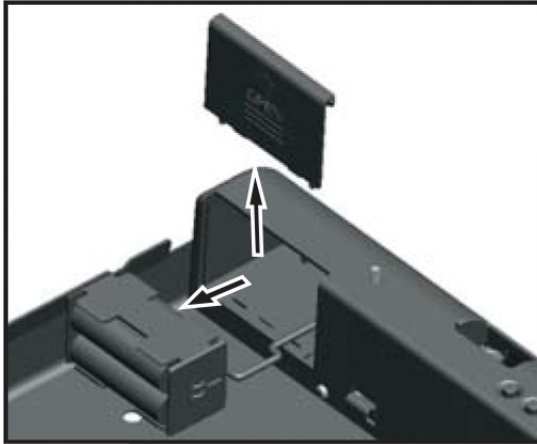

Figure 2

## FINGERPRINT REGISTRATION

### !!!!!! WARNING !!!!!

**If you do not register any fingerprints then the safe will open if the “Start” button is pressed.**

**MAKE SURE YOU REGISTER AT LEAST ONE (1) FINGERPRINT.**

There are TWO (2) types of fingerprint registrations:

- 1) “Administrator” Fingerprints
- 2) “User” Fingerprints

The first three(3) fingerprints registered are “Administrator” fingerprints. These “Administrator” fingerprints are required prior to enrolling each “User” fingerprint. “User” fingerprints cannot enroll more “User” fingerprints.

In order to register “User” fingerprints, an “Administrator’s” fingerprint must first be entered.

## ENROLLING ADMINISTRATOR FINGERPRINTS

### READ THIS PROCESS COMPLETELY BEFORE STARTING

#### (ADMIN #1)

1) Press and release the “ENROLL” button located on the inside of the safe. You will hear ONE (1) beep and the LED light will begin to flash green. The sensor will light up as well.

(See Figure 3)

2) Place your finger on the sensor and HOLD for over TWO (2) seconds. You will hear ONE (1) beep and then another ONE (1) beep and finally TWO (2) quick beeps. The LED light will flash green for a successful enrollment. ADMIN 1 is now enrolled. If, the LED light flashed red then it was a failed enrollment.

#### (ADMIN #2)

1) **For the second administrator enrollment**, Press and release the “ENROLL” button located on the inside of the safe. You will hear ONE (1) beep and the LED light will begin to flash green and the sensor will light up indicating the enrollment process has started. Place **ADMIN #1** finger on the sensor. You will hear TWO (2) quick beeps then quickly remove your finger.

2) Now place the **ADMIN #2** finger on the sensor and HOLD for over TWO (2) seconds. You will hear ONE (1) beep and then another ONE (1) beep and finally TWO (2) quick beeps. The LED light will flash green for a successful enrollment. The LED light will flash red for a failed enrollment. **REPEAT FOR ADMIN #3**  
See next page for enrolling “User” fingerprints.

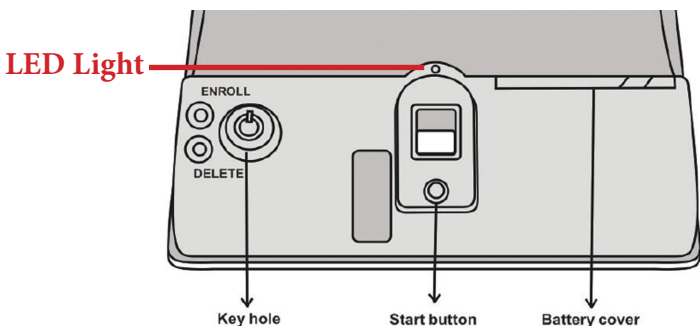

Figure 3

## ENROLLING USER FINGERPRINTS

### READ THIS PROCESS COMPLETELY BEFORE STARTING

- 1) Press and release the “ENROLL” button located on the inside of the safe. You will hear ONE (1) beep and the LED light will begin to flash green and the sensor will light up indicating the enrollment process has started.
- 2) Place one of the registered **“Administrator”** fingers on the sensor. You will hear TWO (2) beeps indicating that a “User” fingerprint may now be enrolled.
- 3) Now place the **“User”** finger on the sensor and HOLD for over TWO (2) seconds. You will hear ONE (1) beep and then another ONE (1) beep and finally TWO (2) quick beeps. The LED light will flash green for a successful enrollment. The LED light will flash red for a failed enrollment.

*NOTE: For better enrollment success, once you place your finger on the sensor, DO NOT MOVE, DO NOT ROTATE, DO NOT SHAKE, DO NOT SLIDE, DO NOT TWIST your finger. Keep it as steady as possible until the LED light turns off.*

Repeat this process for up to ONE HUNDRED AND SEVENTEEN (117) “User” enrollments.

## OPENING THE SAFE AFTER SETUP

Press and release the start button. The LED light flashes green and beeps once.

Place and hold your finger on the sensor. The LED light will flash green two times and will hear two beeps. Then the unit will open.

## LOCKING THE SAFE

- 1) Close the lid and press firmly on the lid. You will hear a “Click”.
- 2) Check to make sure it is locked by lifting up on the lid.

## TROUBLE ENROLLING FINGERPRINTS

### **IMPORTANT SUGGESTIONS:**

For better enrollment success, once you place your finger on the sensor, **DO NOT MOVE, DO NOT ROTATE, DO NOT SHAKE, DO NOT SLIDE, and DO NOT TWIST** your finger. Keep it as steady as possible until the LED light turns off.

- **Finger Location:** Try registering multiple fingerprints with the same finger but register each at different angles on the sensor.
- **Women & Children:** If you are having trouble registering your index finger, try using your thumbs.
- **Dry Fingers:** Try breathing on your fingers before putting them on the scanner. The extra moisture sometimes helps with fingerprint recognition.
- **Age:** Fingerprints get thinner with age and sometimes certain fingerprints do not present enough unique “identifiers” that are required to enroll a user. This is the limiting factor of fingerprint recognition technology to date.

## DELETING FINGERPRINTS

You cannot delete just a single fingerprint. ALL of the fingerprints enrolled will be deleted. First, press and release the “delete” button, then put an administrator finger on the scanner. After successful scan, press and release the “start” button. TWO (2) green LED flashes and TWO (2) beeps will indicate successful deletion.

## SOUND ON/OFF

**Turn Sound OFF:** Press and hold the start button for FIVE (5) seconds.

**Turn Sound ON:** Press and hold the start button for FIVE (5) seconds.

## CHANGING THE BATTERIES

**Please refer to page 4: Opening your safe for the first time.**

At least once a year, replace the four (4) AA alkaline batteries with batteries that have a “use date” of at least 5 years in the future.  
(Recommended battery brands: Duracell™, Energizer™, Eveready™)



## SECURITY CABLE & ELASTIC STRAP

### **SECURE YOUR SAFE:**

Using the Security Cable: (See Figure 4 below)

- 1) Wrap the security cable around a secure object.
- 2) Run the end of cable through the loop end of the cable and pull tight.
- 3) Open the safe and place the end of the cable (not the loop) through the left side slot in the back of the safe.
- 4) Close the safe lid and lock the safe.
- 5) Check to make sure the cable is secured by pulling on the safe.



Figure 4



Figure 5

### **ELASTIC STRAP:**

To Remove the Strap:

Press down on the metal hoops near the side hooks then pull toward the center of the safe. Do this to both sides.

(See Figure 5 above)

To Install the Strap:

Hook one of the metal hoops under one of the side hooks. Then pull the other metal hoop to the other side hook and push it down and under the hook. Make sure to keep tension on the first hook.

# WARRANTY

## LIMITED WARRANTY

Tracker Safe hereby warrants to the original purchaser that each new safe will be free from defects in materials and craftsmanship for one (1) year. This warranty applies only to safes located in the United States and that have been used for Residential use only.

Safe Contents: This warranty only applies to the Tracker Safe itself; the warranty does not extend to the personal property stored in the safe.

Tracker Safe's obligation under this Limited Warranty is contingent upon proper use, installation, and maintenance of the safe and does not apply to the safe or parts that have been misused, neglected, or exposed to unreasonable wear and tear, or exposed to unusual or extreme environments. Modifying or changing the safe in ways that alter or effect the safe's intended operation or use will void this warranty. The decision to repair a safe in purchaser's home, at the factory, or to replace the safe, is solely that of Tracker Safe. If the safe is to be repaired at the factory or replaced, Tracker Safe will pay for the freight back to the factory. The purchaser is responsible for packaging the safe at their own expense. Tracker Safe does not cover any costs to package, remove or install the safe.

To receive support under Tracker Safe's Limited Warranty the purchaser must provide the following:

- 1) Proof of Purchase
- 2) Warranty Registration Form

Warranty Registration Form: The warranty registration form is located in the Tracker Safe Owner Use and Care Manual that came with the safe. To validate this warranty, the original purchaser must fill out the warranty registration form and mail it to Tracker Safe within sixty (60) days of purchase (or register online at [trackersafe.com](http://trackersafe.com)).

The above warranty is given in place of all other warranties and assurances, whether expressed or implied, including warranties to fitness for purpose, quality, or merchantability. Tracker Safe accepts no liability, under any circumstances, for any incidental or consequential damage or loss suffered by anyone, or to any property, as a result of using or being unable to use the safe.

Any claims arising from this limited warranty shall be resolved in the State of Washington and Washington law will apply to any dispute.

**TRACKER SAFE  
WARRANTY REGISTRATION FORM**

Please provide us with a copy of your receipt along with this registration form within sixty (60) days from original purchase date. *Or Register online at [TrackerSafe.com](http://TrackerSafe.com)*

Name: \_\_\_\_\_

Address: \_\_\_\_\_

City: \_\_\_\_\_

State: \_\_\_\_\_ Zip: \_\_\_\_\_

Phone: \_\_\_\_\_

Email: \_\_\_\_\_

Date of Purchase: \_\_\_\_\_

Model Number: \_\_\_\_\_

Safe Serial Number: : \_\_\_\_\_

Purchased From: \_\_\_\_\_

Comments:

---

---

---

Mail to:  
Tracker Safe LLC  
6317 NE 63rd Street  
Vancouver, WA 98661