



# Tiger Lifting



[www.tigerlifting.com](http://www.tigerlifting.com)

**Tiger**

Home of the Tiger hoisting, winching and height safety ranges

## Tiger Bulb Flat Bar Anchor/Clamp

Model No. BCB



1.5t unit (BCB-0150)



3t unit (BCB-0300)

### Main Features

- 1.5t and 3.0t capacities available
- Quick and versatile rigging point for hoisting equipment when attached to bulb flat bars approved for lifting applications
- Shackle suspension point
- No tools required – integrated adjusting screw spindle
- Operating temperature of -50°C to +50°C
- Up to 45° side loading with no deration
- 15° cross loading with no deration
- 4:1 factor of safety, even at the above angles

These units meet and exceed all the requirements within BS EN 13155:2003.

### Certification:

Each unit comes fully certified with a test certificate or an EC Declaration of Conformity stating compliance with the essential health and safety requirements of the Machinery Directive 2006/42/EC.

The Tiger BCB bulb bar anchor is designed for attaching to bulb profiles of bulb flat bars approved for lifting applications. These are often found in ship compartments, engine rooms and overhead bridge deck structures. The bulb bar anchor provides a semi-permanent lifting point. The large integrated shackle gives easy connection for all different types of lifting machines.

\*\* Please note that this model must NOT be used for lifting beams. It is a suspension point.





# Tiger Lifting



[www.tigerlifting.com](http://www.tigerlifting.com)

**Tiger**

Home of the Tiger hoisting, winching and height safety ranges

Our BCB bulb flat bar anchor can be side loaded up to 45° and cross loaded up to 15° without derating the unit, whilst still maintaining a 4:1 factor of safety.

**Warning: Ensure the handle is fully tight before commencing operation.**

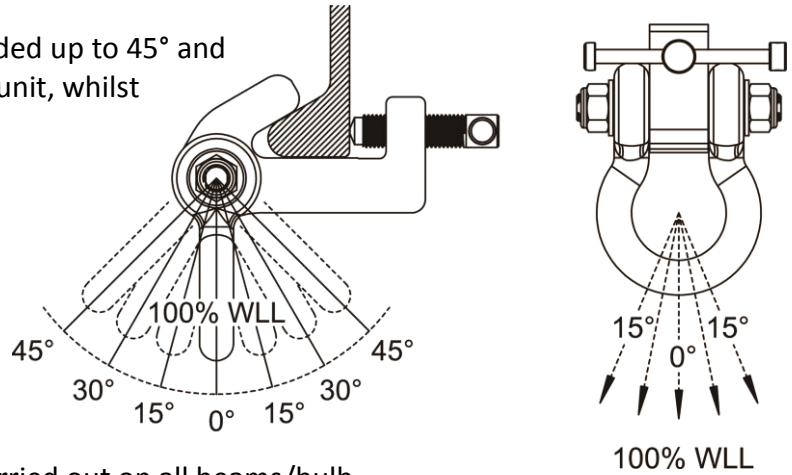

**Recommendation:**

We advise that structural calculations are carried out on all beams/bulb flat bars and supporting steel work by qualified engineering departments to ensure safe operation.

**Marking:**



**Technical Data**

| Product Code | Capacity (tonne) | Dimensions (mm) |    |         |         |    |    |    | Net Weight (kg) |
|--------------|------------------|-----------------|----|---------|---------|----|----|----|-----------------|
|              |                  | A               | B  | C       | D       | E  | F  | G  |                 |
| BCB-0150     | 1.5              | 160-240         | 36 | 173-200 | 125-151 | 58 | 71 | 22 | 3.6             |
| BCB-0300     | 3.0              | 240-320         | 42 | 214-241 | 155-182 | 68 | 94 | 25 | 6.4             |

A=bulb flat width

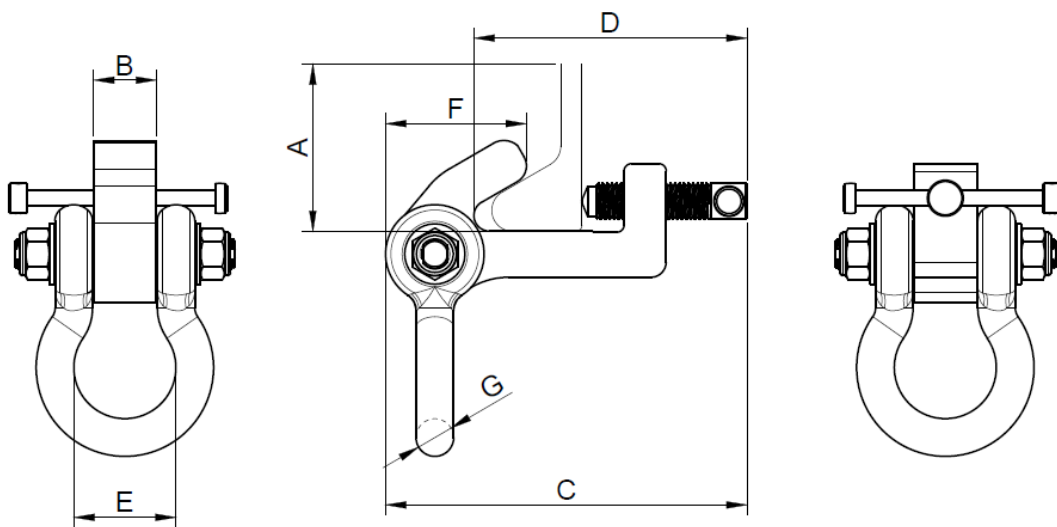

Due to our policy of continual product development, dimensions, weights and specifications may change without prior notice. Please check with your Tiger sales team when ordering.

