

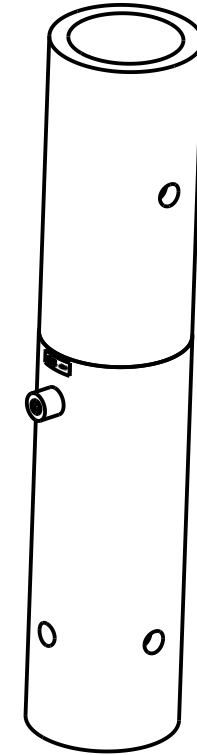

Product number: IN-2426

∅ 101,6
[4.000]

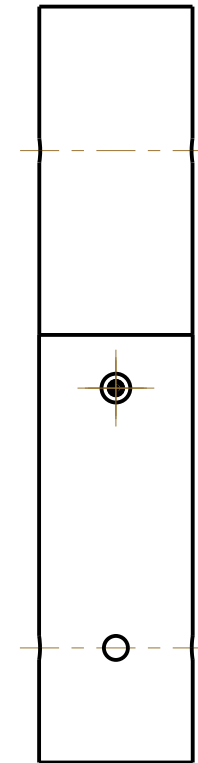
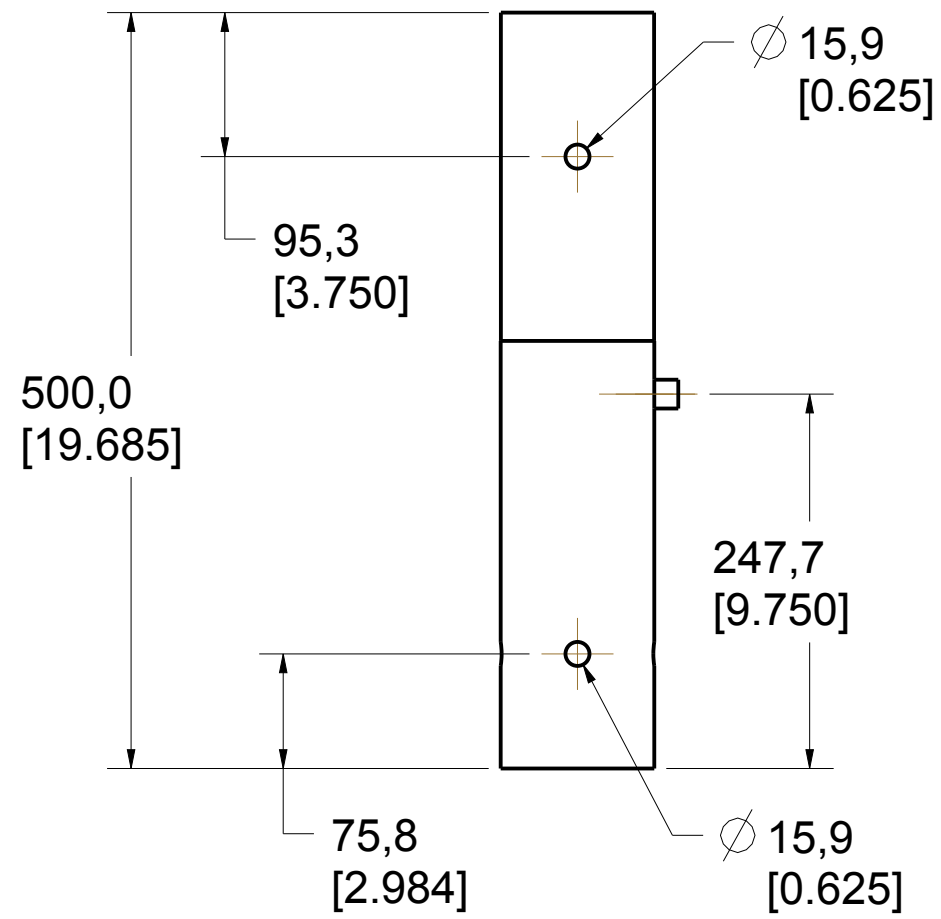
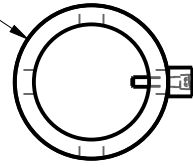

PAT.NO.:				
PRODUITS DE SERVICE PUBLICS INNOVA INC. INNOVA PUBLIC UTILITY PRODUCTS INC.				
© 9105-0732 QUEBEC INC. and under exclusive license to INNOVA PUBLIC UTILITY PRODUCTS INC., (hereafter « INNOVA »). All rights reserved. Protected under the Copyright Act of Canada and international treaties and agreements regarding copyrights. Violators are subject to prosecution and other legal recourses for infringement. Any reproduction, adaptation or other use or disclosure whatsoever, in totality or in part, and in any form or by any means whatsoever, strictly forbidden and requires the prior written approval of INNOVA. All data is the exclusive property of 9105-0732 QUEBEC INC. and under exclusive license to INNOVA and cannot be used nor disclosed in any way either without the prior written approval of INNOVA.				
WEIGHT:	TITLE:			
11 Lb	Mast for davit arm 30" to 48"			
5 Kg	500mm (19.7) high			
COLOR:	Material:	SHEET(S):	PROJET:	Rev.
Safety yellow	Aluminum	1 / 4	IN-2426	01

Product number: IN-2426

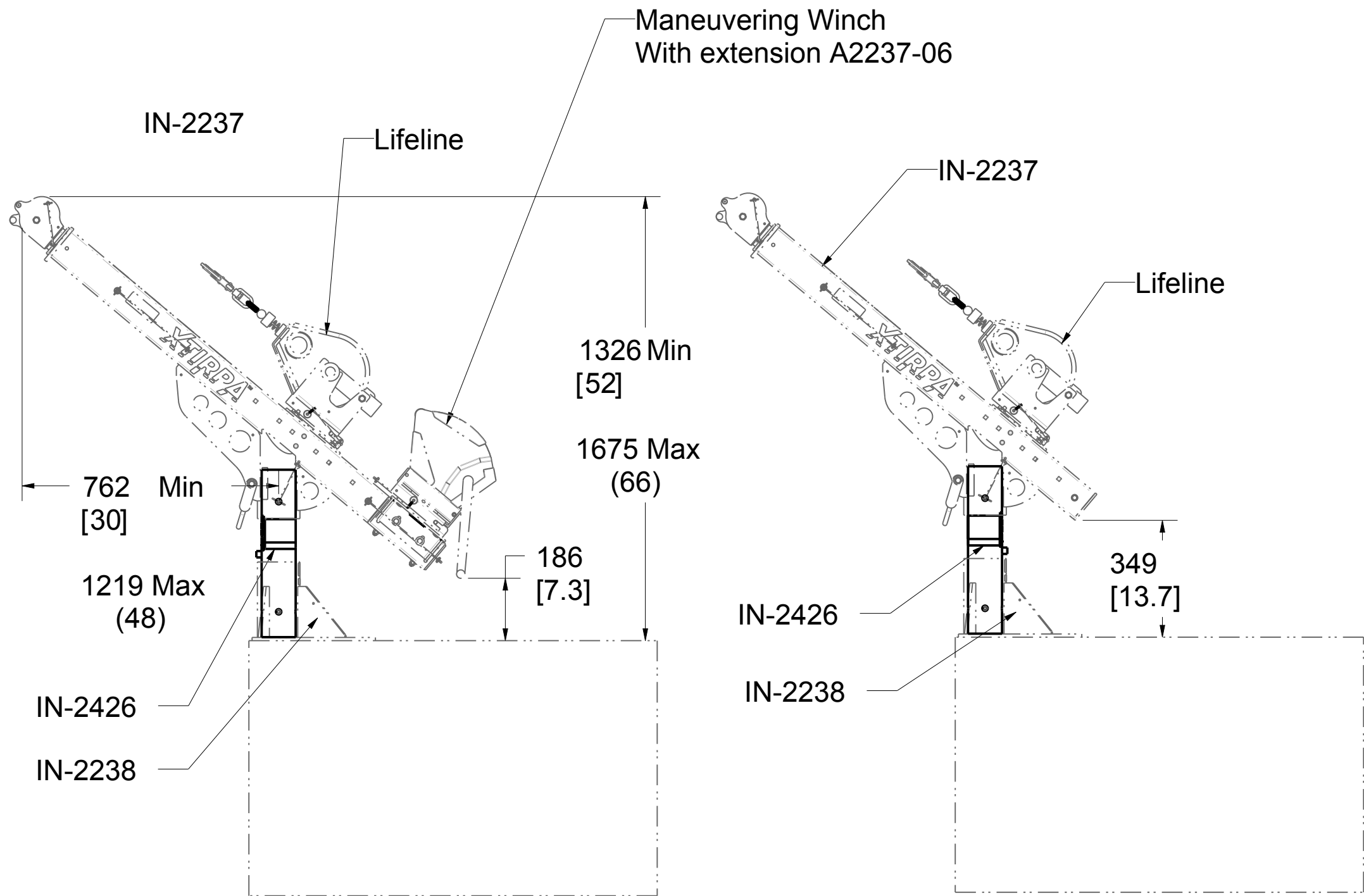
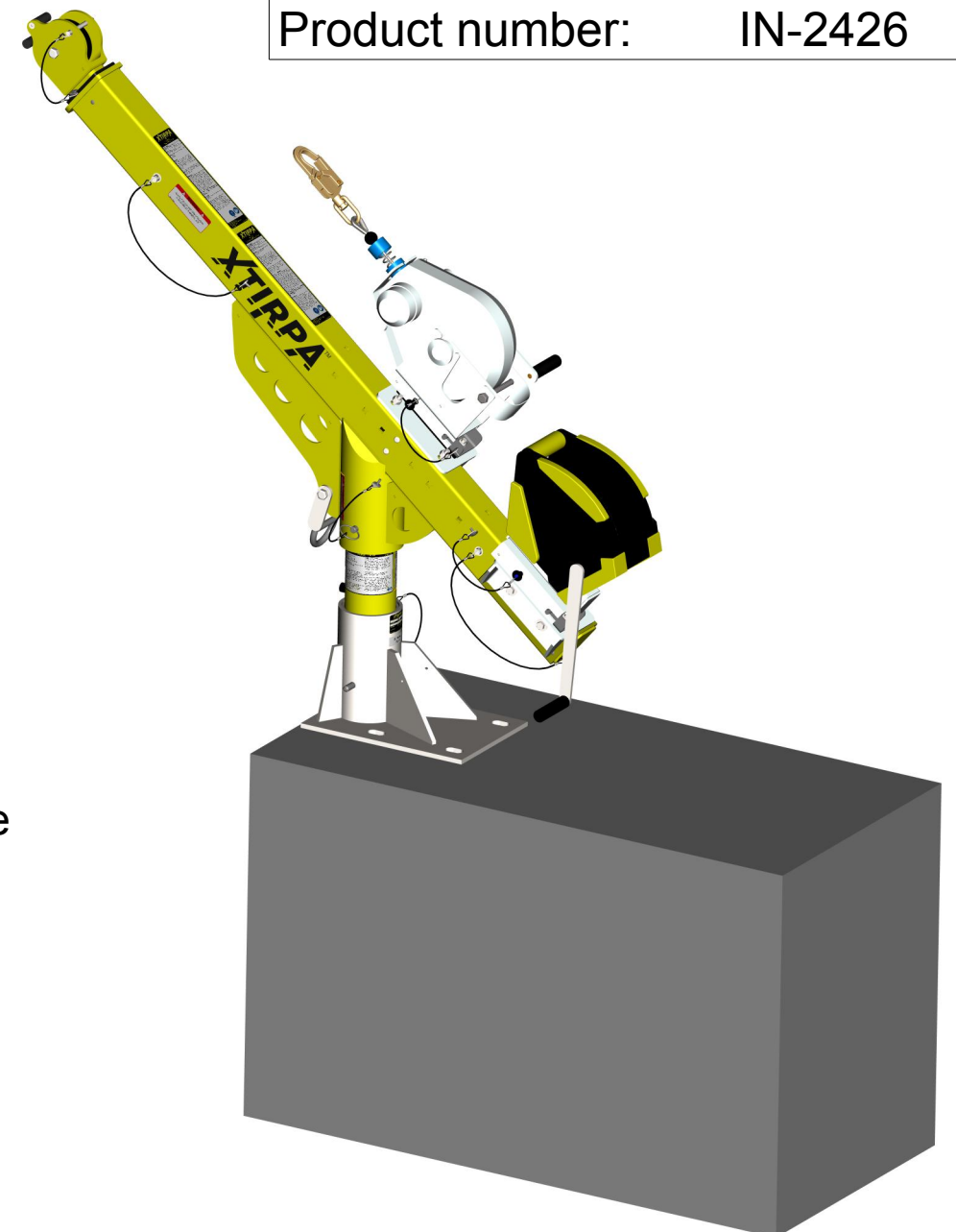

PAT.NO.:

PRODUITS DE SERVICE PUBLICS INNOVA INC.
 INNOVA PUBLIC UTILITY PRODUCTS INC.

© 9105-0732 QUEBEC INC. and under exclusive license to INNOVA PUBLIC UTILITY PRODUCTS INC., (hereafter « INNOVA »). All rights reserved. Protected under the Copyright Act of Canada and international treaties and agreements regarding copyrights. Violators are subject to prosecution and other legal recourses for infringement. Any reproduction, adaptation or other use or disclosure whatsoever, in totality or in part, and in any form or by any means whatsoever, strictly forbidden and requires the prior written approval of INNOVA. All data is the exclusive property of 9105-0732 QUEBEC INC. and under exclusive license to INNOVA and cannot be used nor disclosed in any way either without the prior written approval of INNOVA.

WEIGHT:	TITLE:
11 Lb	Mast for davit arm 30" to 48"
5 Kg	500mm (19.7) high

COLOR:	Material:	SHEET(S):	PROJET:	Rev.
Safety yellow	Aluminum	2 / 4	IN-2426	01

SPECIFICATIONS

This equipment is considered as part of a personal fall arrest system (PFAS) with a maximum working capacity of 164 Kg (360 lb).

It is only to be used in conjunction with a personal fall arrest system that limits the maximum arrest force (MAF).

Max Working load (mass):
 With Davit-Arm IN-2237: 164 kg (360 lb)
 Max working moment with Davit-Arm IN-2237: 1,952 N-m (17,280 lbf-in)

Max design capacity: with Davit-Arm IN-2237: 16,014 N (3,600 lbf)
 Max design moment with Davit-Arm IN-2237: 19,524 N-m (172,800 lbf-in).

STANDARDS

Meets the following standards:
 OSHA Personal fall arrest system - 1910.66 App C
 ANSI Safety requirements for personal fall arrest system, subsystems and components Z359.1 - 2007
 CAN/CSA Fall arresters, vertical lifelines, and rails Z259.2.1-98
 CE EN 795: 2012 Type A ,Type B and type E.
 TS 16415:2013

MATERIAL AND CONSTRUCTION

Mast : Aluminum 6061-T6
 Finish : Yellow security powder paint with metal protection base.

RESTRICTIONS

This product is to be used only with products approved by Innova public utility products INC.

IMPORTANT :

**The positioning pins must always be in place when manouvering personnel. Otherwise, serious injuries may occur.
 Periodic inspections of hardware must be done.
 In the occurance of a fall or the safety of the equipment is in doubt, equipment must be immediately removed from service and inspected by qualified personnel before reuse.

** This equipment must always be operated in a level position.

Product number: IN-2426

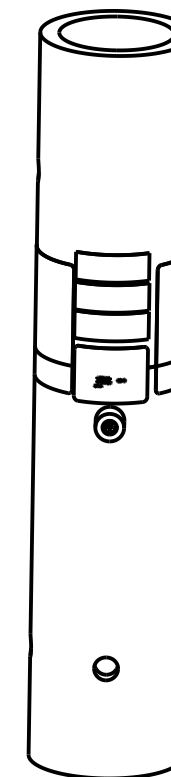

PAT.NO.:				
PRODUITS DE SERVICE PUBLICS INNOVA INC. INNOVA PUBLIC UTILITY PRODUCTS INC.				
<small>© 9105-0732 QUEBEC INC. and under exclusive license to INNOVA PUBLIC UTILITY PRODUCTS INC., (hereafter « INNOVA »). All rights reserved. Protected under the Copyright Act of Canada and international treaties and agreements regarding copyrights. Violators are subject to prosecution and other legal recourses for infringement. Any reproduction, adaptation or other use or disclosure whatsoever, in totality or in part, and in any form or by any means whatsoever, strictly forbidden and requires the prior written approval of INNOVA. All data is the exclusive property of 9105-0732 QUEBEC INC. and under exclusive license to INNOVA and cannot be used nor disclosed in any way either without the prior written approval of INNOVA.</small>				
WEIGHT:	TITLE:			
11 Lb	Mast for davit arm 30" to 48"			
5 Kg	500mm (19.7) high			
COLOR:	Material:	SHEET(S):	PROJET:	Rev.
Safety yellow	Aluminum	3 / 4	IN-2426	01

8

7

6

5

4

3

2

1

H
G
F
E
D
C
B
A

H
G
F
E
D
C
B
A

Product number: IN-2426

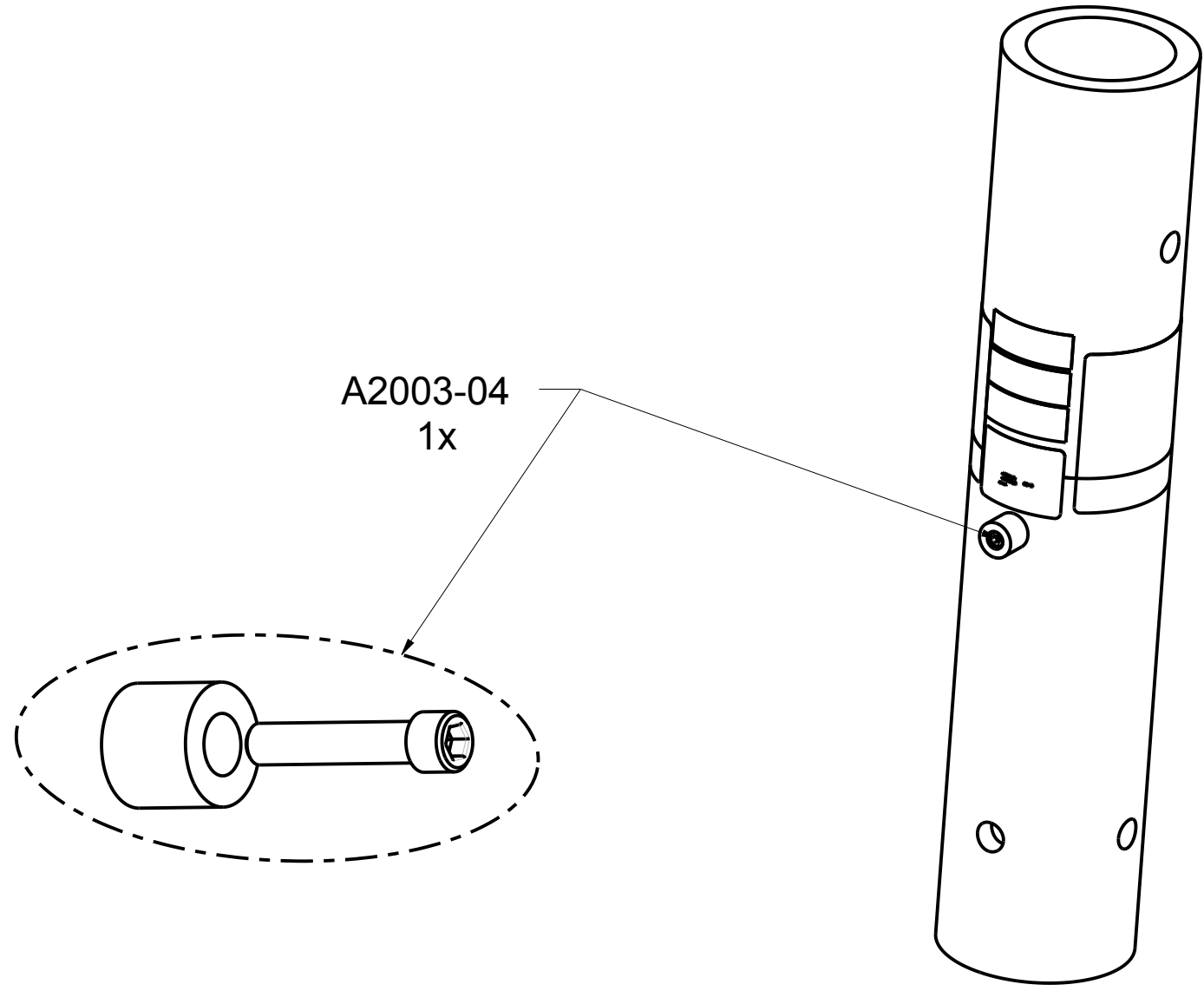

A2003-04
1x

PAT.NO.:				
PRODUITS DE SERVICE PUBLICS INNOVA INC. INNOVA PUBLIC UTILITY PRODUCTS INC.				
© 9105-0732 QUEBEC INC. and under exclusive license to INNOVA PUBLIC UTILITY PRODUCTS INC., (hereafter « INNOVA »). All rights reserved. Protected under the Copyright Act of Canada and international treaties and agreements regarding copyrights. Violators are subject to prosecution and other legal recourses for infringement. Any reproduction, adaptation or other use or disclosure whatsoever, in totality or in part, and in any form or by any means whatsoever, strictly forbidden and requires the prior written approval of INNOVA. All data is the exclusive property of 9105-0732 QUEBEC INC. and under exclusive license to INNOVA and cannot be used nor disclosed in any way either without the prior written approval of INNOVA.				
WEIGHT:	TITLE:			
11 Lb	Mast for davit arm 30" to 48"			
5 Kg	500mm (19.7) high			
COLOR:	Material:	SHEET(S):	PROJET:	Rev.
Safety yellow	Aluminum	4 / 4	IN-2426	01

8

7

6

5

4

3

2

1