

Product number: IN-2380

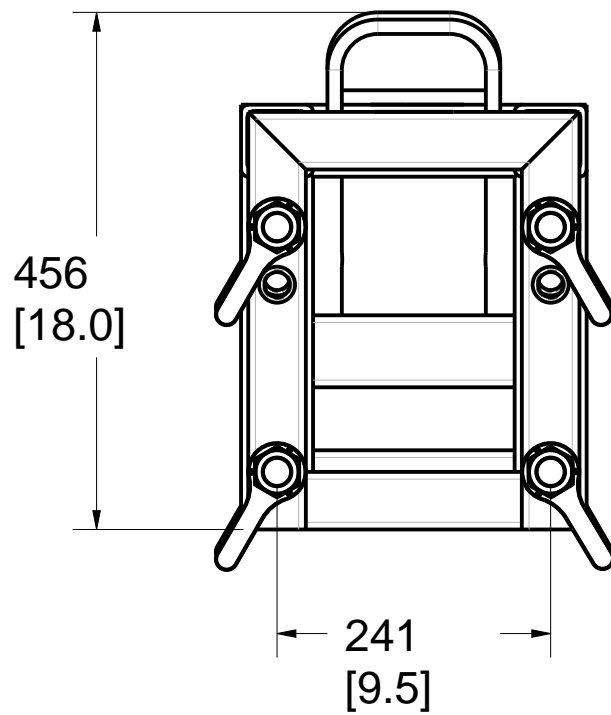
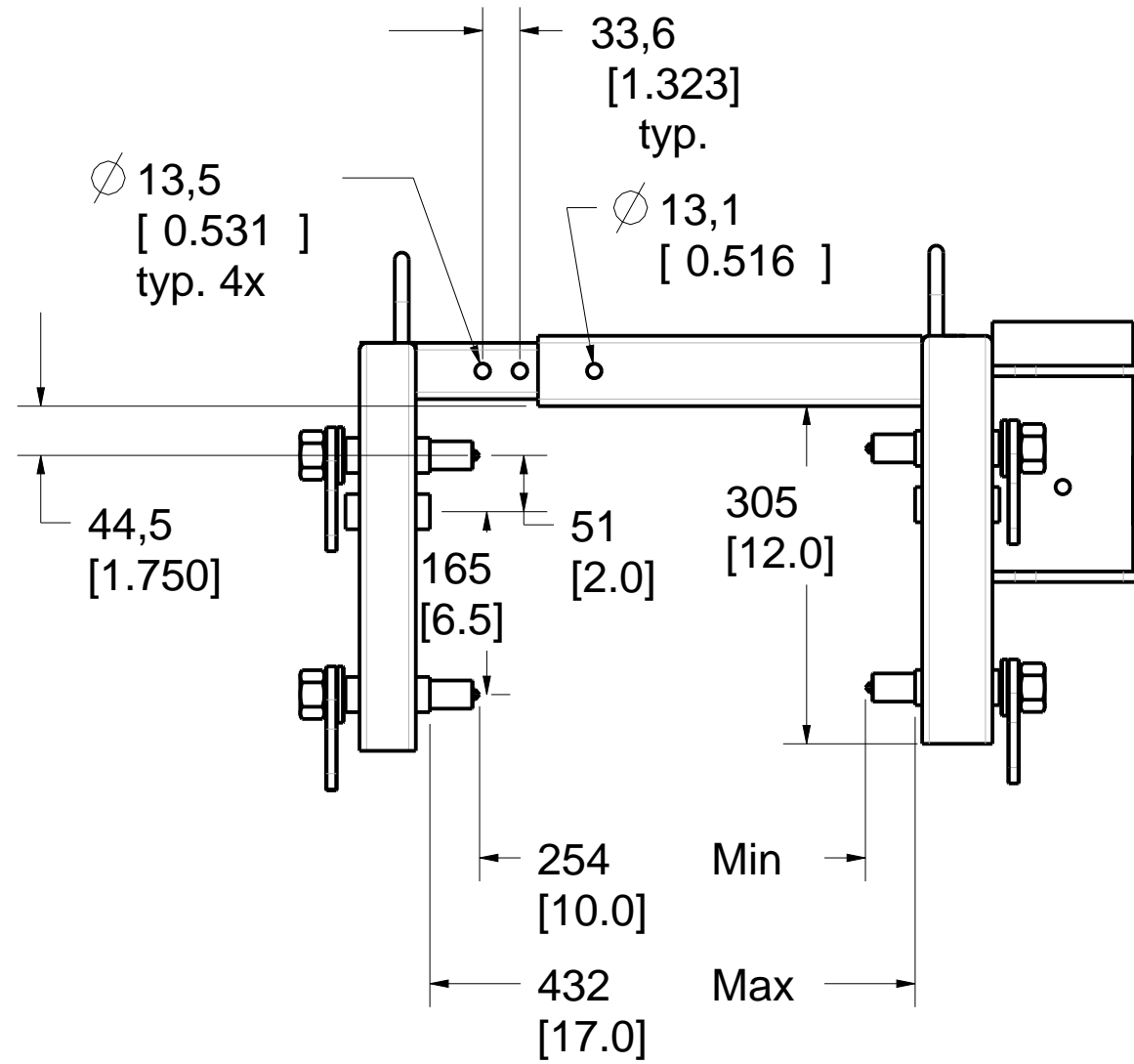
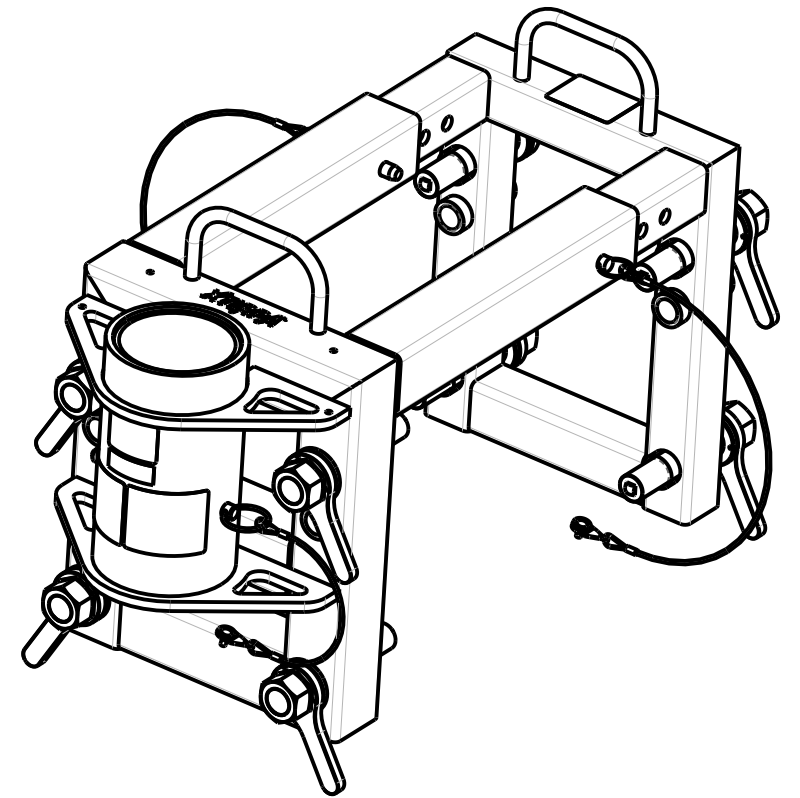
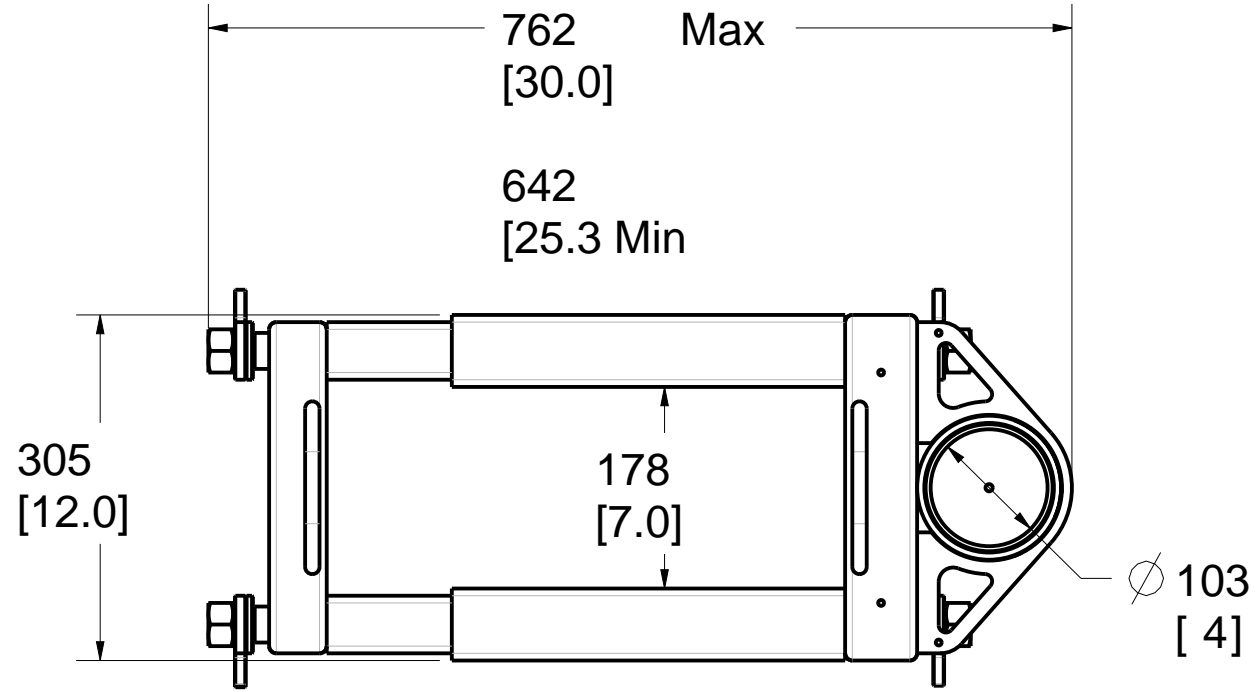

PAT. NO.:		©12/01/2015	©
<b>PRODUITS DE SERVICE PUBLICS INNOVA INC.</b> <b>INNOVA PUBLIC UTILITY PRODUCTS INC.</b>			
<small>© 9105-0732 QUEBEC INC. and under exclusive license to INNOVA PUBLIC UTILITY PRODUCTS INC., (hereafter « INNOVA »). All rights reserved. Protected under the Copyright Act of Canada and international treaties and agreements regarding copyrights. Violators are subject to prosecution and other legal recourses for infringement. Any reproduction, adaptation or other use or disclosure whatsoever, in totality or in part, and in any form or by any means whatsoever, strictly forbidden and requires the prior written approval of INNOVA. All data is the exclusive property of 9105-0732 QUEBEC INC. and under exclusive license to INNOVA and cannot be used nor disclosed in any way either without the prior written approval of INNOVA.</small>			
WEIGHT:	TITLE:		
108 Lb	102mm (4") Adjustable wall adapter		
49 Kg	254mm à 432mm (10"-17")		
COLOR:	MATERIAL:	SHEET(S):	PROJECT:
Zinc plated	Steel	1 / 4	IN-2380

Recommendations:

Concrete must be made of 0,2% gross area rebar reinforced 13.8 MPa (2000psi) or better  
 Minimum thickness of 254mm (10")  
 OR  
 Non reinforced Concrete  
 13.8 MPa (2000psi) or better.  
 Minimum thickness of 286mm (11 1/4")

Moment capacity:  
 19,524 N-m (172,800 lbf-in)  
 Vertical load: 22,241 N (5,000 lbf).  
 N.B. It is the responsibility of the field engineer to assure installation compliance.

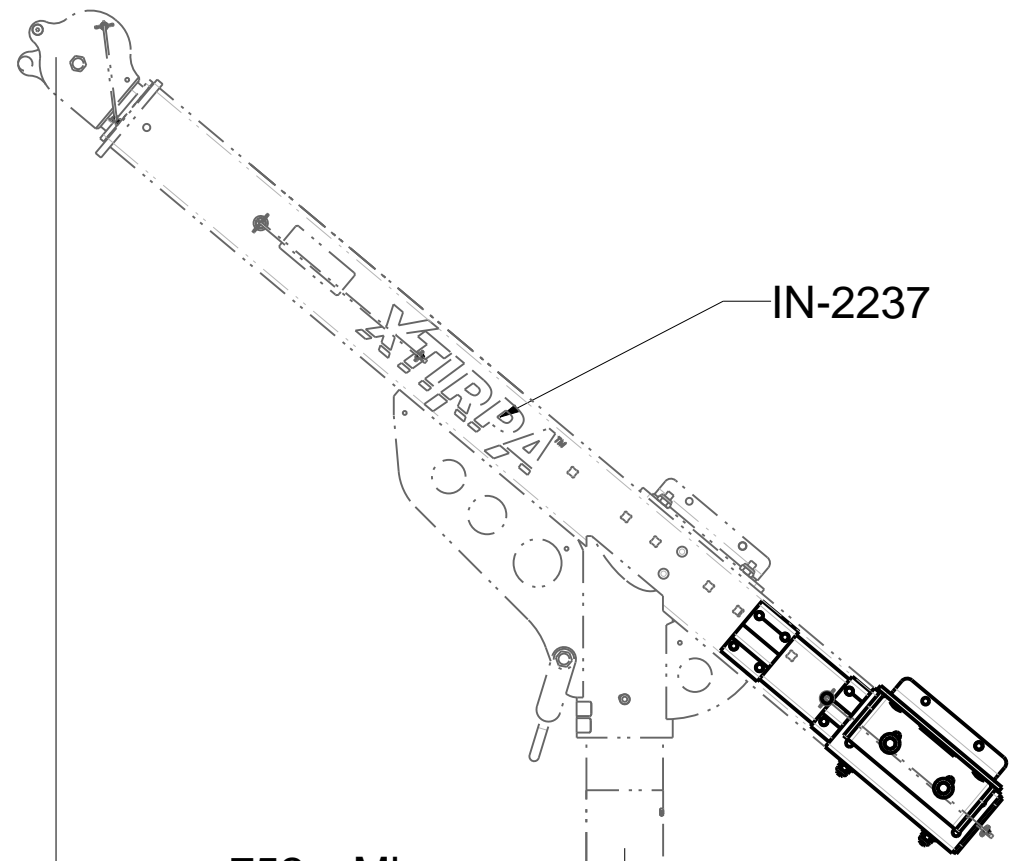

752 Min  
[30]

1219  
[48] Max

IN-2240

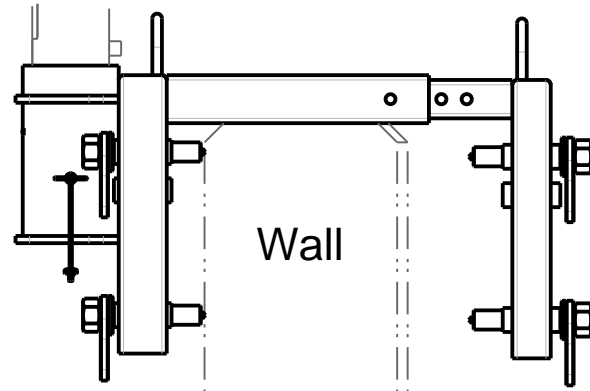

Wall

254 Min  
[10.0]

432  
[17.0] Max

Torque Value (8x)  
 34-41 N-m (25-30 lbf-ft) .

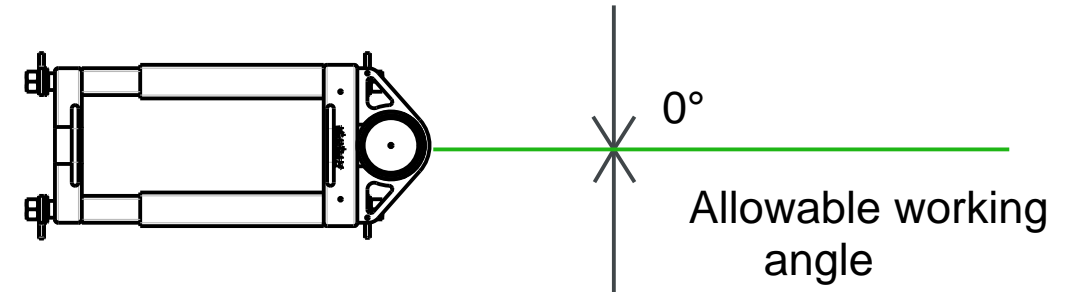

0°  
 Allowable working angle

PAT. NO.:		©12/01/2015	©
PRODUITS DE SERVICE PUBLICS INNOVA INC. INNOVA PUBLIC UTILITY PRODUCTS INC.			
© 9105-0732 QUEBEC INC. and under exclusive license to INNOVA PUBLIC UTILITY PRODUCTS INC., (hereafter « INNOVA »). All rights reserved. Protected under the Copyright Act of Canada and international treaties and agreements regarding copyrights. Violators are subject to prosecution and other legal recourses for infringement. Any reproduction, adaptation or other use or disclosure whatsoever, in totality or in part, and in any form or by any means whatsoever, strictly forbidden and requires the prior written approval of INNOVA. All data is the exclusive property of 9105-0732 QUEBEC INC. and under exclusive license to INNOVA and cannot be used nor disclosed in any way either without the prior written approval of INNOVA.			
WEIGHT:	TITLE:		
108 Lb 49 Kg	102mm (4") Adjustable wall adapter 254mm à 432mm (10"-17")		
COLOR:	MATERIAL:	SHEET(S):	PROJECT:
Zinc plated	Steel	2 / 4	IN-2380

**SPECIFICATIONS**

This equipment is considered as part of a personal fall arrest system (PFAS) with a maximum working capacity of 164 Kg (360 lb).

It is only to be used in conjunction with a personal fall arrest system that limits the maximum arrest force (MAF).

Maximum working moment : 1,952 N-m (17,280 lbf-in)

Maximum moment : 19,520 N-m (172,800 lbf-in)

**STANDARDS**

Meets the following standards:

OSHA Personal fall arrest system - 1910.66 App C

ANSI Safety requirements for personal fall arrest system, subsystems and components Z359.1 ( R1999 ) / 2007

CAN/CSA Fall arresters, vertical lifelines, and rails Z259.2.1-98

CE EN 795: 2012 Type B

**MATERIAL AND CONSTRUCTION**

Structure : Zinc plated Steel

Sleeve bearing : PVC pipe

Hardware : Zinc plated steel

Pin : Stainless steel

Lanyard : Nylon covered stainless steel cable

Welding certification : CSA W59 & W47.1, AWS D1.6

**RESTRICTIONS**

This product is to be used only with products approved by Inova Public Utility Products inc.

**IMPORTANT :**

A minimum of 4 adjustment pins shall be used at all times on each side of the structure.

Always use the product perpendicular to the wall. It is not considered as a permanent structure.

\*\*The positioning pins must always be in place when manoeuvring personnel. Otherwise, serious injuries may occur.

Periodic inspections of hardware must be done.

In the occurrence of a fall or the safety of the equipment is in doubt, equipment must be immediately removed from service and inspected by qualified personnel before reuse.

\*\* This equipment must always be operated in a level position.

Product number: IN-2380

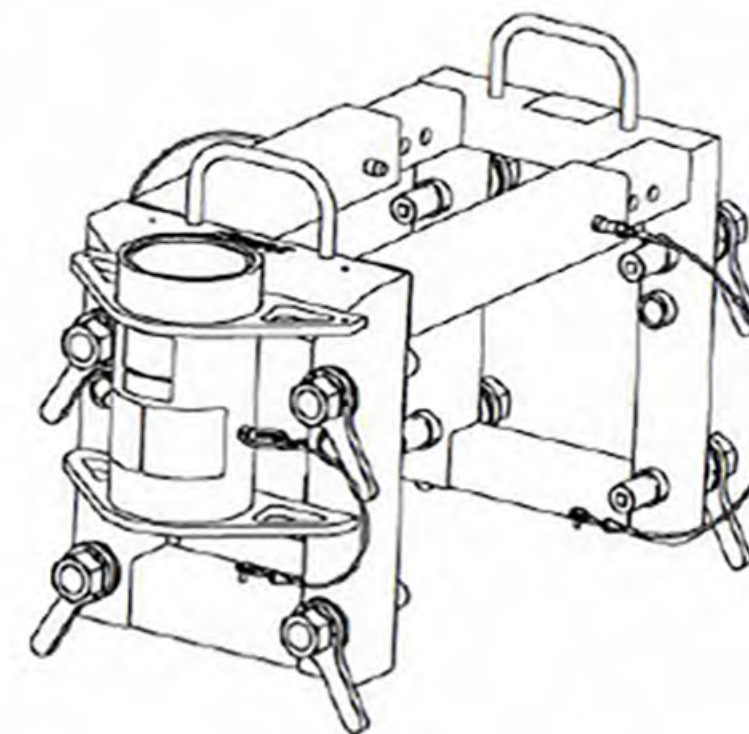

PAT. NO.:		012/01/2015 ©	
PRODUITS DE SERVICE PUBLICS INNOVA INC. INNOVA PUBLIC UTILITY PRODUCTS INC.			
<small>© 2005-0730 QUEBEC INC. and under exclusive license to INNOVA PUBLIC UTILITY PRODUCTS INC., (Inventeur &amp; DÉPOSITAIRE), All rights reserved. Protected under the Copyright Act of Canada and international treaties and agreements regarding copyrights. Violators are subject to prosecution and will be held responsible for damages, any reproduction, adaptation or other use or disclosure whatsoever, in whole or in part, and in any form or by any means electronic, strictly forbidden and requires the prior written approval of INNOVA. All data is the exclusive property of 0730-0730 QUEBEC INC. and under exclusive license to INNOVA and cannot be used nor disclosed in any way without the prior written approval of INNOVA.</small>			
WEIGHT:	TITLE:		
108 lb	102mm (4") Adjustable wall adapter		
49 Kg	254mm ø 432mm (10"-17")		
COLOR:	MATERIAL:	SHEET(S):	PROJECT:
Zinc plated	Steel	3 / 4	IN-2380

8

7

6

5

4

3

2

1

Product number: IN-2380

IDX	QTE	COMPONENT	REV	DESCRIPTION	MATERIAL
6	1	S2001-003	E	XTIRPA Label	
5	1	S2324-004	Rev.A	Security Label CE type B	
4	1	S2001-005	RevC	Label XTIRPA serial number	
3	1	S2197-005		Label "Manipulate two person"	
2	1	S2482-001		All Wall Adapter universal Sticker	
1	1	S2380-001	RevB	All wall adapter 4" (102mm)	

H  
G  
F  
E  
D  
C  
B  
A

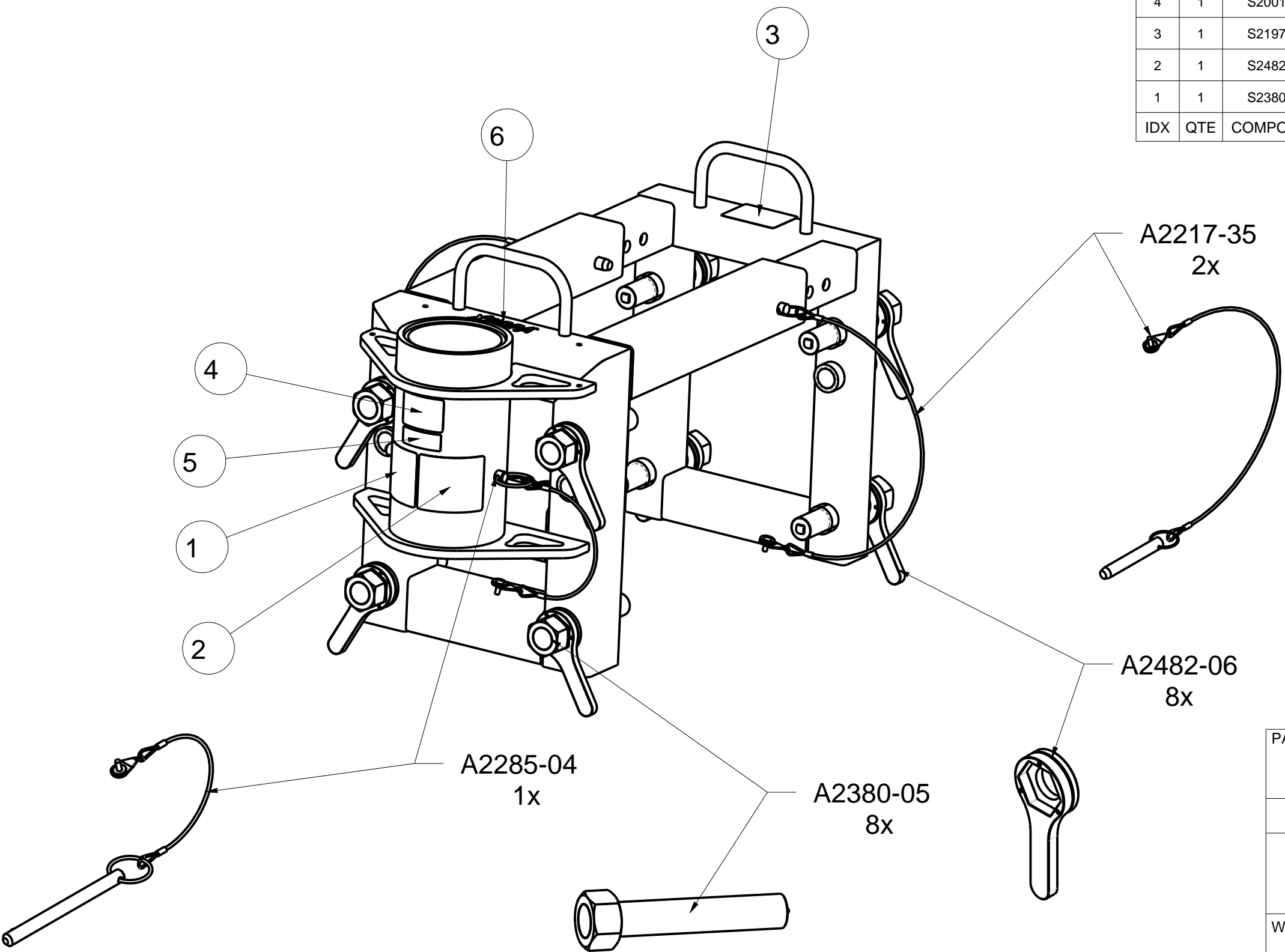

PAT. NO.:		©12/01/2015	©
<b>PRODUITS DE SERVICE PUBLICS INNOVA INC.</b> <b>INNOVA PUBLIC UTILITY PRODUCTS INC.</b>			
<small>© 9105-0732 QUEBEC INC. and under exclusive license to INNOVA PUBLIC UTILITY PRODUCTS INC., (hereafter « INNOVA »). All rights reserved. Protected under the Copyright Act of Canada and international treaties and agreements regarding copyrights. Violators are subject to prosecution and other legal recourses for infringement. Any reproduction, adaptation or other use or disclosure whatsoever, in totality or in part, and in any form or by any means whatsoever, strictly forbidden and requires the prior written approval of INNOVA. All data is the exclusive property of 9105-0732 QUEBEC INC. and under exclusive license to INNOVA and cannot be used nor disclosed in any way either without the prior written approval of INNOVA».</small>			
WEIGHT:	TITLE:		
108 Lb	102mm (4") Adjustable wall adapter		
49 Kg	254mm à 432mm (10"-17")		
COLOR:	MATERIAL:	SHEET(S):	PROJECT:
Zinc plated	Steel	4 / 4	IN-2380

8

7

6

5

4

3

2

1