

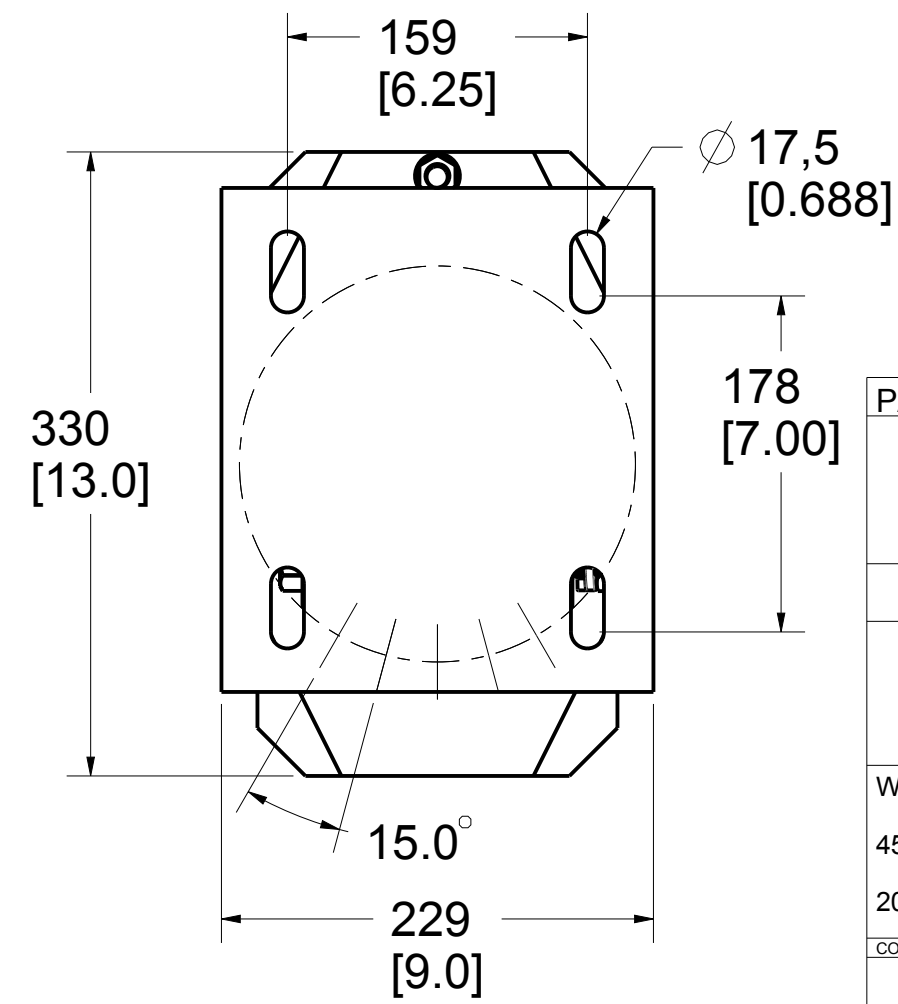

Product number: IN-2314

H
G
F
E
D
C
B
A

H
G
F
E
D
C
B
A

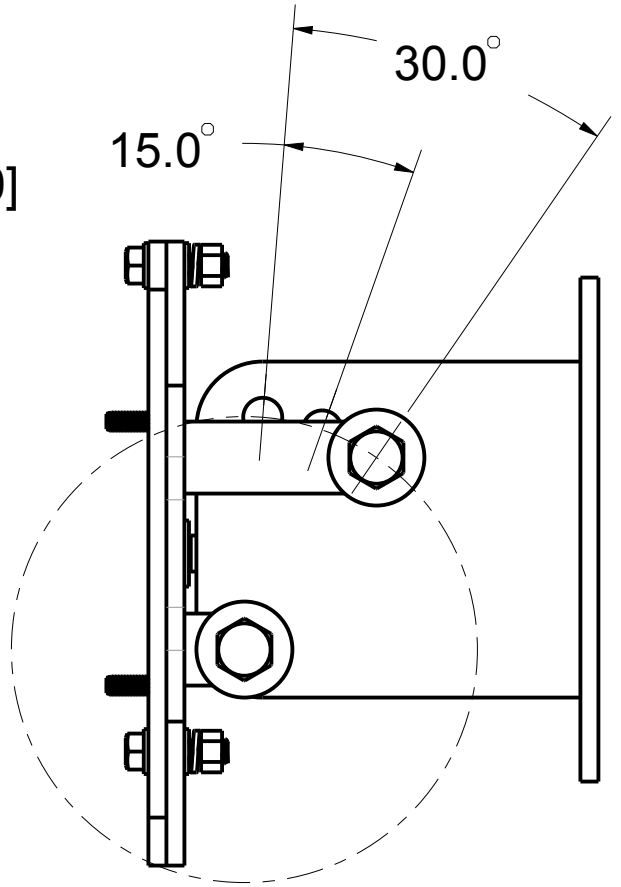
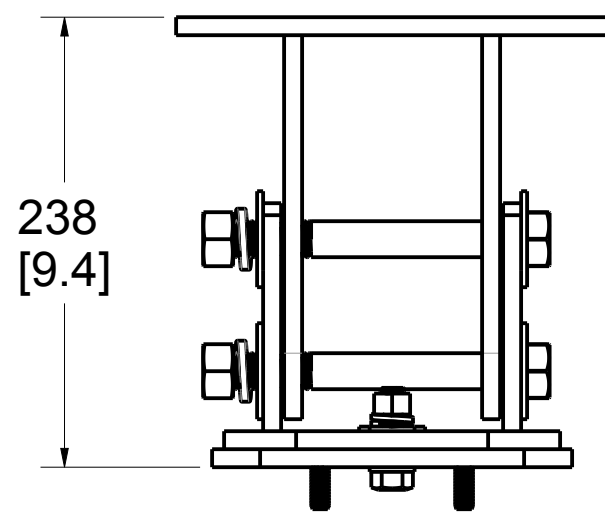
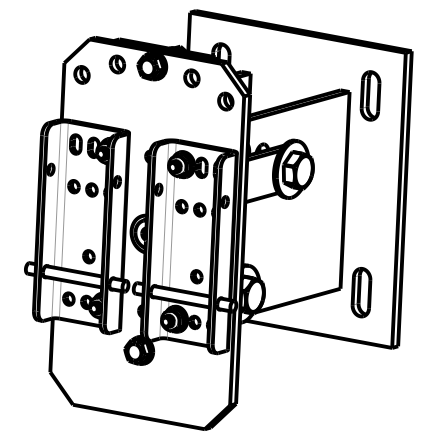
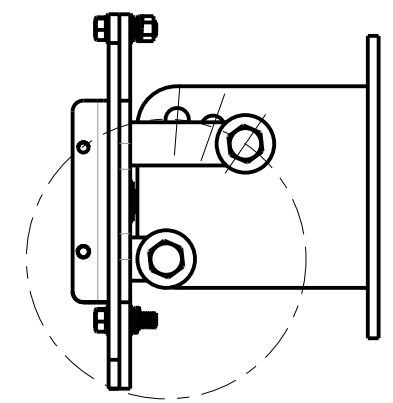
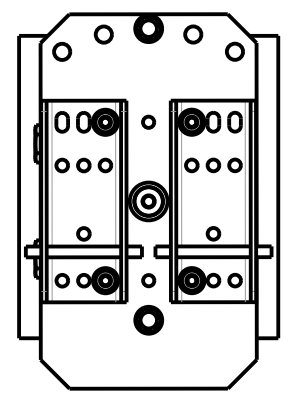
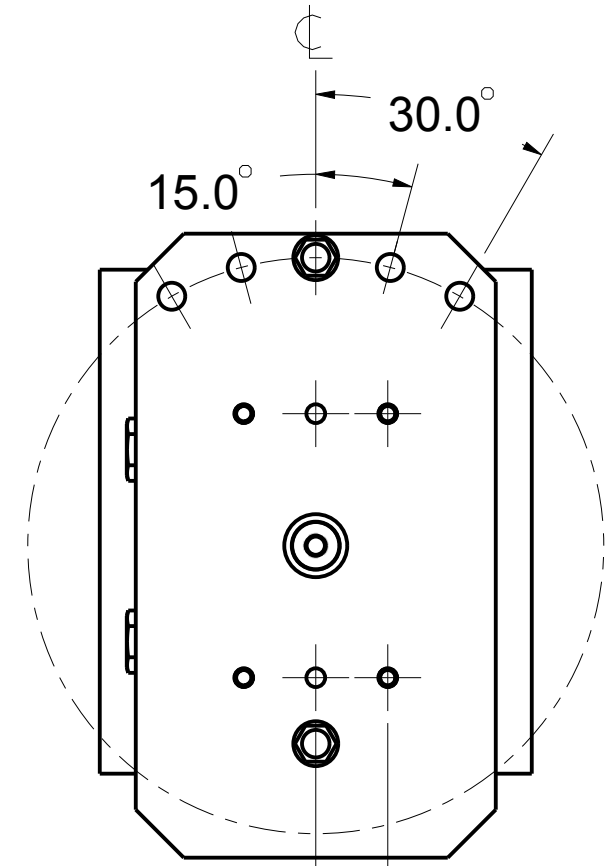

PAT.NO.:				
PRODUITS DE SERVICE PUBLICS INNOVA INC. INNOVA PUBLIC UTILITY PRODUCTS INC.				
<small>© 9105-0732 QUEBEC INC. and under exclusive license to INNOVA PUBLIC UTILITY PRODUCTS INC., (hereafter « INNOVA »). All rights reserved. Protected under the Copyright Act of Canada and international treaties and agreements regarding copyrights. Violators are subject to prosecution and other legal recourses for infringement. Any reproduction, adaptation or other use or disclosure whatsoever, in totality or in part, and in any form or by any means whatsoever, strictly forbidden and requires the prior written approval of INNOVA. All data is the exclusive property of 9105-0732 QUEBEC INC. and under exclusive license to INNOVA and cannot be used nor disclosed in any way either without the prior written approval of INNOVA.</small>				
WEIGHT:	TITLE:			
45.0 Lb	Wall mount SRL/winch			
20.4 Kg	adapter (adjustable)			
COLOR:	Material:	SHEET(S):	PROJET:	Rev.
	Stainless 304	1 / 4	IN-2314	01

8 7 6 5 4 3 2 1

8 7 6 5 4 3 2 1

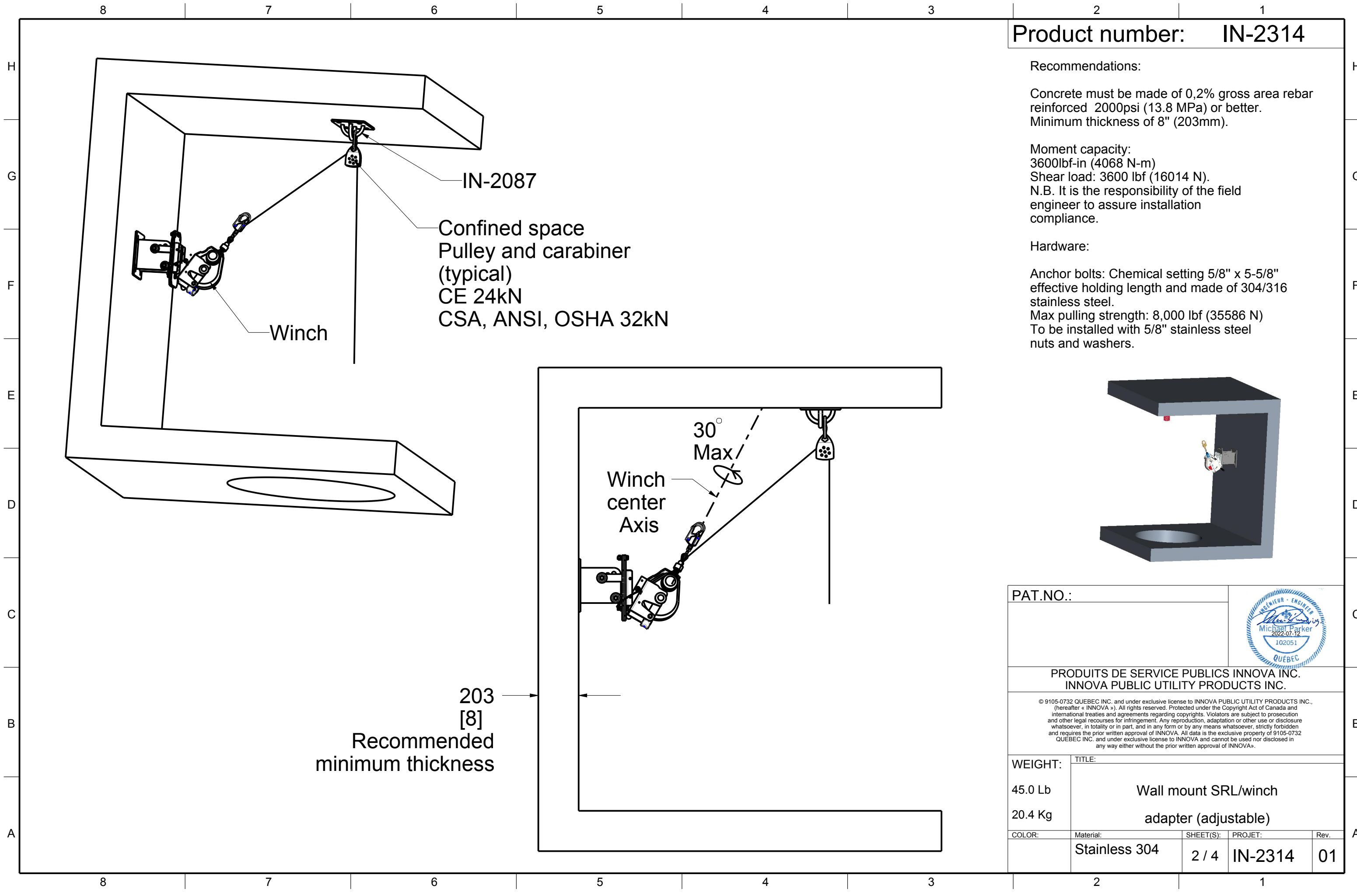



Product number: **IN-2314**

Recommendations:
 Concrete must be made of 0,2% gross area rebar reinforced 2000psi (13.8 MPa) or better. Minimum thickness of 8" (203mm).

Moment capacity:
 3600lbf-in (4068 N-m)
 Shear load: 3600 lbf (16014 N).
 N.B. It is the responsibility of the field engineer to assure installation compliance.

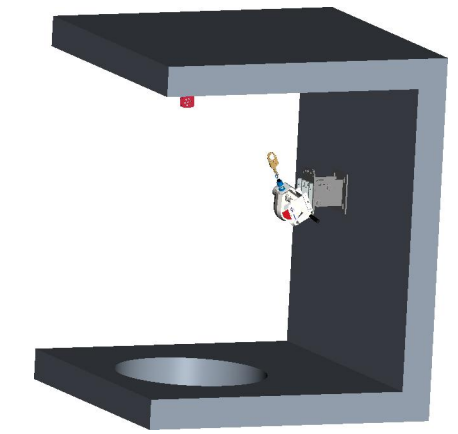
Hardware:
 Anchor bolts: Chemical setting 5/8" x 5-5/8" effective holding length and made of 304/316 stainless steel.
 Max pulling strength: 8,000 lbf (35586 N)
 To be installed with 5/8" stainless steel nuts and washers.



PAT.NO.:

PRODUITS DE SERVICE PUBLICS INNOVA INC.
 INNOVA PUBLIC UTILITY PRODUCTS INC.

© 9105-0732 QUEBEC INC. and under exclusive license to INNOVA PUBLIC UTILITY PRODUCTS INC., (hereafter « INNOVA »). All rights reserved. Protected under the Copyright Act of Canada and international treaties and agreements regarding copyrights. Violators are subject to prosecution and other legal recourses for infringement. Any reproduction, adaptation or other use or disclosure whatsoever, in totality or in part, and in any form or by any means whatsoever, strictly forbidden and requires the prior written approval of INNOVA. All data is the exclusive property of 9105-0732 QUEBEC INC. and under exclusive license to INNOVA and cannot be used nor disclosed in any way either without the prior written approval of INNOVA.

WEIGHT:	TITLE:			
45.0 Lb	Wall mount SRL/winch adapter (adjustable)			
20.4 Kg				

COLOR:	Material:	SHEET(S):	PROJET:	Rev.
	Stainless 304	2 / 4	IN-2314	01

SPECIFICATIONS

This equipment is considered as part of a personal fall arrest system (PFAS).

It is only to be used in conjunction with a personal fall arrest system that limits the maximum arrest force (MAF) to 6.0 kN.

Working load limit (WLL) : 164 kg (360 lb)
 Minimum breaking strength for anchorage 1 (F1) : 16,0 kN (3 600 lbf)
 Minimum breaking strength for anchorage 2 (F2) : 16,0 kN (3 600 lbf)

STANDARDS

Name	Classification	Year	Users
ANSI Z359.1		1992 (R1999)	1
CSA Z259.2.1		1998 (R2011)	1
OSHA 1910.66			1
EN 795	A		1

MATERIAL AND CONSTRUCTION

Structure : Stainless Steel
 Welding procedure : CSA W59.18 / CSA W47.1 & AWS D1.6
 Surface Finishing : N / A

RESTRICTIONS

This equipment is to be used only with products approved by Innova Public Utility Products Inc.

This equipment must always be operated on a level surface.

Ensure that all hardware and connecting pins are properly installed before use.

In the occurrence of a fall or the safety of the equipment is in doubt, the equipment must be immediately removed from service and inspected by qualified personnel before reuse.

Product number: **IN-2314**

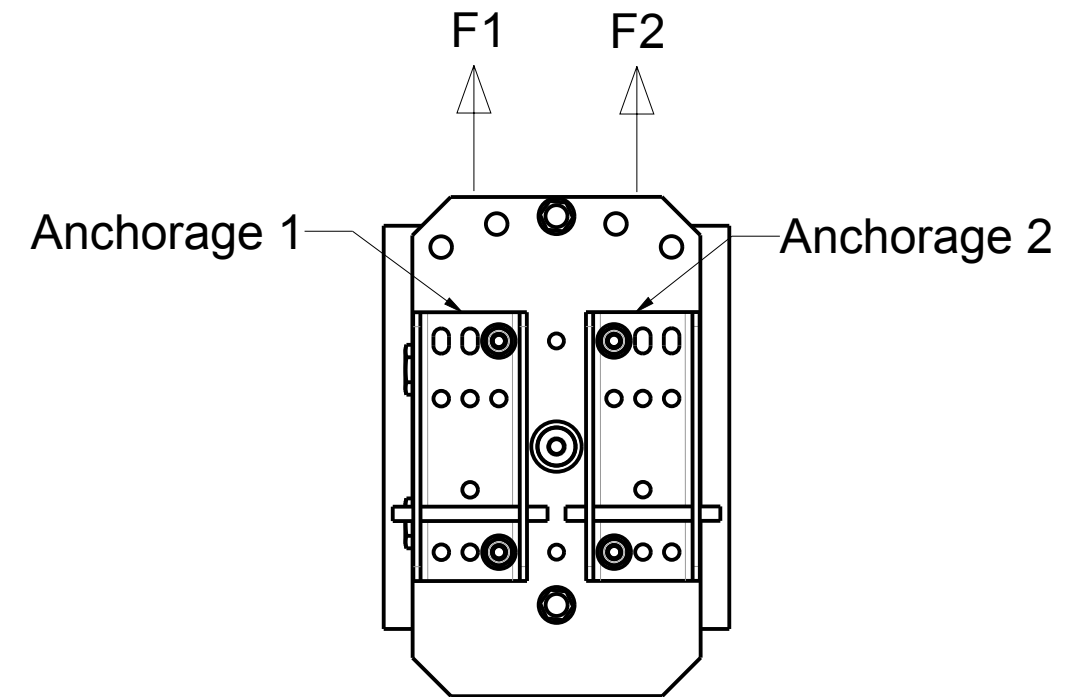

PAT.NO.:			
PRODUITS DE SERVICE PUBLICS INNOVA INC. INNOVA PUBLIC UTILITY PRODUCTS INC.			
© 9105-0732 QUEBEC INC. and under exclusive license to INNOVA PUBLIC UTILITY PRODUCTS INC., (hereafter « INNOVA »). All rights reserved. Protected under the Copyright Act of Canada and international treaties and agreements regarding copyrights. Violators are subject to prosecution and other legal recourses for infringement. Any reproduction, adaptation or other use or disclosure whatsoever, in totality or in part, and in any form or by any means whatsoever, strictly forbidden and requires the prior written approval of INNOVA. All data is the exclusive property of 9105-0732 QUEBEC INC. and under exclusive license to INNOVA and cannot be used nor disclosed in any way either without the prior written approval of INNOVA®.			
WEIGHT:	TITLE:		
45.00 Lb	Wall mount SRL/winch adapter (adjustable)		
20.41 Kg	Material:	SHEET(S):	PROJET:
	Stainless 304	3 / 4	IN-2314
			Rev. 01

8

7

6

5

4

3

2

1

Product number: IN-2314

H

G

F

E

D

C

B

A

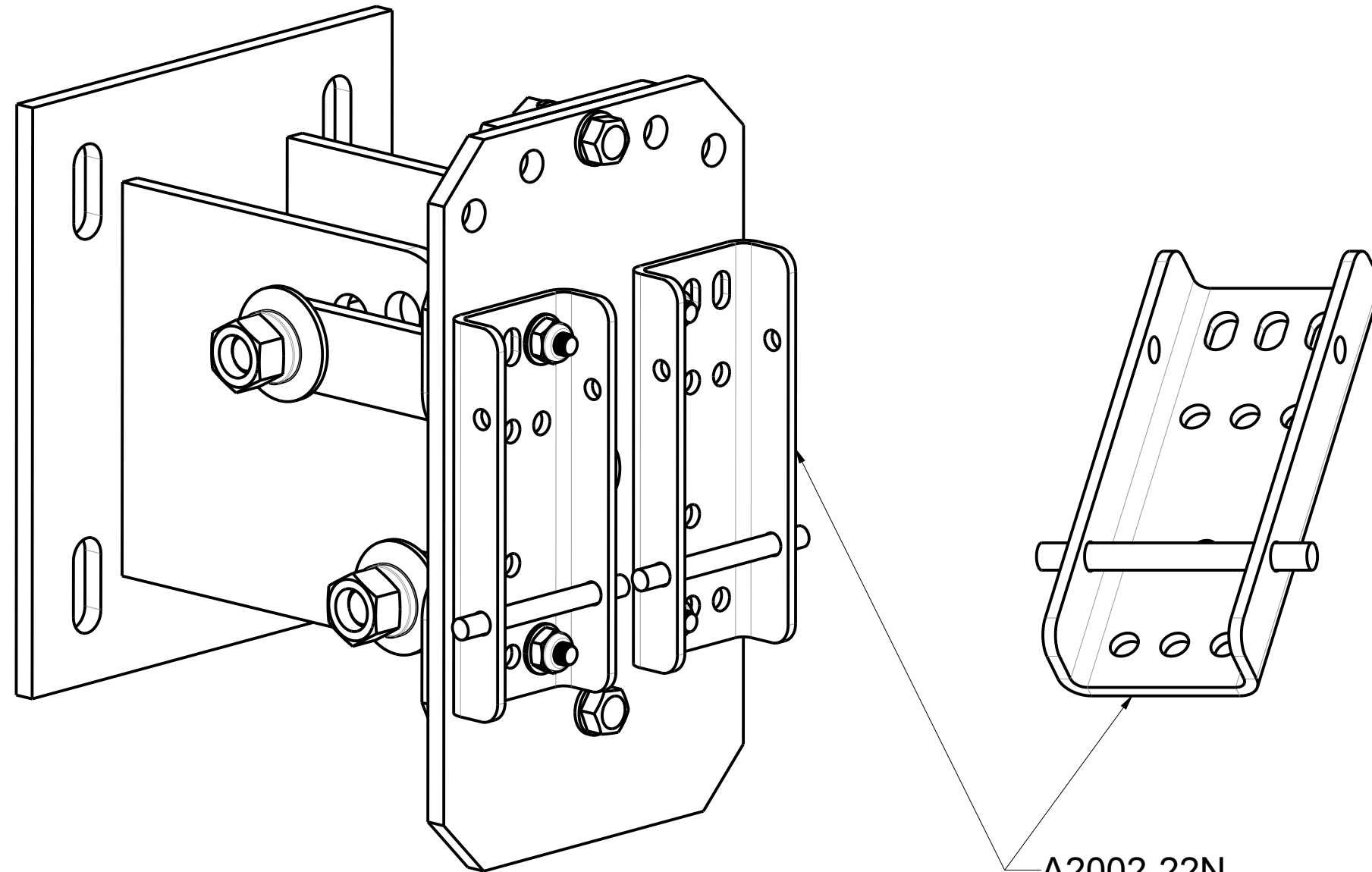

A2002-22N
2x

PAT.NO.:				
PRODUITS DE SERVICE PUBLICS INNOVA INC. INNOVA PUBLIC UTILITY PRODUCTS INC.				
<small>© 9105-0732 QUEBEC INC. and under exclusive license to INNOVA PUBLIC UTILITY PRODUCTS INC., (hereafter « INNOVA »). All rights reserved. Protected under the Copyright Act of Canada and international treaties and agreements regarding copyrights. Violators are subject to prosecution and other legal recourses for infringement. Any reproduction, adaptation or other use or disclosure whatsoever, in totality or in part, and in any form or by any means whatsoever, strictly forbidden and requires the prior written approval of INNOVA. All data is the exclusive property of 9105-0732 QUEBEC INC. and under exclusive license to INNOVA and cannot be used nor disclosed in any way either without the prior written approval of INNOVA».</small>				
WEIGHT:	TITLE:			
45.0 Lb	Wall mount SRL/winch			
20.4 Kg	adapter (adjustable)			
COLOR:	Material:	SHEET(S):	PROJET:	Rev.
	Stainless 304	4 / 4	IN-2314	01

8

7

6

5

4

3

2

1