

Operating Instructions & Safety Manual



Vertical Plate Clamp

**Rated Capacities
0.5 to 16 tonnes**

Note: Operator must read and fully understand the operating instructions before using this product.

Products supplied comply with the essential health & safety requirements of the Machinery Directive 2006/42/EC, the Supply of Machinery (Safety) Regulations 2008 and the Health & Safety at Work etc Act 1974 section 6.



Safety Information



For your safety and correct operation, please carefully read the manual before use.

GENERAL

This manual contains important information for the correct installation, operation and maintenance of the equipment described herein. The use of any clamp presents some risk of personal injury or property damage. All persons involved in such installation, operation and maintenance should be thoroughly familiar with the contents of this manual. To safeguard against the possibility of property damage or personal injury follow the recommendations and instructions of this manual and keep it for further reference.

Aside from transporting plates, this clamp is well suited to turning over steel structures and welded constructions. All plate clamps have been manufactured in accordance with the Machinery Directive 98/37/EC. They are type tested 4 to 1 against breakage. Each unit is proof tested 2 times the rated load.

Do not use the clamps in areas containing flammable vapors, liquids, gasses, combustible dust or fibres. Do not use the clamp in highly corrosive, abrasive, wet environments or in applications involving exposure to temperatures below -40°C or above $+80^{\circ}\text{C}$.

INSTALLATION

Estimate the plate that is to be lifted or moved and make sure it does not exceed the rated load of the clamp.

This clamp with pivoting shackle can be used for lifting and transporting plates at various angles, but the load capacity is reduced, as seen on the diagram below showing the load/force capacities.

The pivoting shackle has the added advantage of providing enough clamping force to hold a plate safely, even when transporting large sized plates with the 2 legged lifting system. Slipping or damage to the clamp is prevented.

When using two clamps to transporting large sized plates, pay attention to the reduced capacities of the clamps.

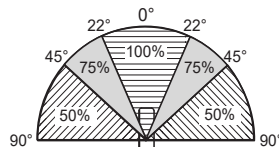
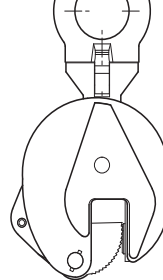
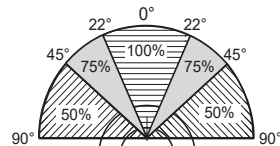

Specification

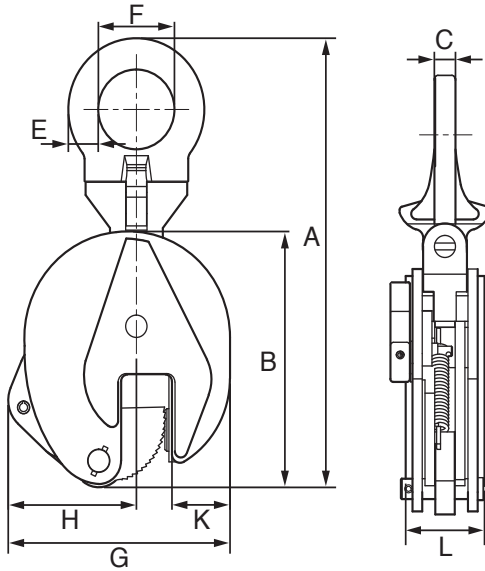

Product Code	Capacity kgs	Jaw Opening mm	A mm	B mm	C mm	D mm	E mm	F mm	G mm	H mm	K mm	Weight kgs
VVPC0.5	500	0 - 15	25	37	128	212	30	98	40	29	10	2
VVPC1	1,000	0 - 20	33	63	170	295	48	145	54	42	12	5
VVPC2	2,000	0 - 25	35	76	205	370	68	175	56	54	18	8
VVPC3	3,000	0 - 30	45	83	237	418	76	215	78	59	20	15
VVPC5	5,000	0 - 50	55	90	262	480	76	232	90	59	20	23
VVPC8	8,000	0 - 45	45	112	330	600	85	263	100	77	22	37
VVPC12	12,000	50 - 90	90	145	380	700	90	390	113	100	25	50
VVPC16	16,000	60 - 100	100	155	410	712	100	425	113	110	30	65

Safety Information

ANGLE INCLINATION

F = Working Load Limit of the clamp

La = Factor

Calculation example: F = 1,000kgs, La = 0.8 ($\beta=50^\circ$).

Rated Load = F • La = 1,000kgs x 50% •
1,00kgsx0.8=400kgs capacity (W.L.L.)
in this lifting method.

The larger the angle of inclination on 2 leg slings the greater is the tension force between the individual slings and damps that has to be taken up in addition to the plate.

The reductions in carrying capacity for the inclinations 45° and from 45° to 60° as shown as follows. Inclination angles larger than 60° are not permissible.

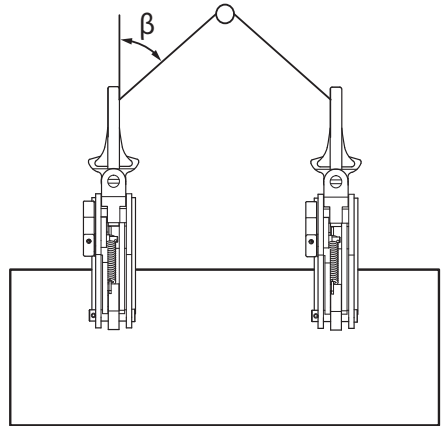

Up to $\beta = 40^\circ - 60^\circ / La=1$

WARNING

Make sure that the plate surface must have a hardness range below HRC 30 / Brinell 300.

DANGER

Make sure that the support to which the pivoting shackle is attached is strong enough to hold several times the weight of the plate.

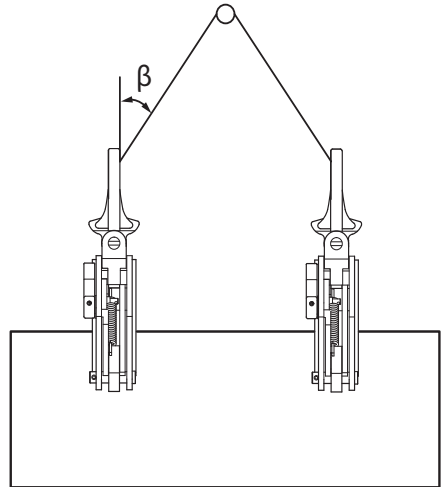

Up to $\beta = 40^\circ / La=1.4$

Safety Information

OPERATION

WARNING

To avoid damage and/or personal injury:

1. Do not exceed maximum load of the clamp.
2. do not use the clamp to lift or transport people.
3. Do not use damaged clamp or clamp that is not working properly.
4. do not lift or transport loads over people and make sure all personnel remain clear of supported plate.
5. Do not lift the plate that is not fully engaged with the clamping jaws.
6. Do not leave load supported by the clamp unattended unless specific precaution has been taken.
7. Do not lift loads that are not balanced, and the holding action is not secure.

DANGER

SAFETY WARNING

- Never exceed maximum capacity.
- Never lift under 20% of the rated capacity used on all hot rolled structural steel plates and sections up to a surface hardness of 300 Brinell/32 Rockwell C.

ATTACHING THE PLATE

Turn the function lever clockwise to disengage the jaws. Then put the plate to the end of the mouth of clamp. Move the function lever counter-clockwise to grip and lock the plate.

LOOSEN LOAD

Move the function lever clockwise to disengage the jaws.

DANGER ZONES

- Do not lift or transport loads while personnel are in the danger zone.
- Do not stand or place hands or feet under the raised plate.
- Raised loads are not to be left unattended for long periods of time.
- The operator may only start to move the load when they are sure the load will not overturn and that all personnel have left the danger zone.

MAINTENANCE/INSPECTION

To maintain continuous and satisfactory operation, a regular inspection procedure must be initiated so that worn or damaged parts can be replaced before they become unsafe.

If faults are detected, the clamp must be put out of service immediately. The intervals of inspection must be determined by the individual application and are based upon the type of service to which the clamp is subjected.

The components of the clamp are to be inspected for damage, wear, corrosion or other irregularities. Repairs may only be carried out by a GT authorised servicer that uses GT Viper spare parts provided by the manufacturer.

Spare Parts Drawing

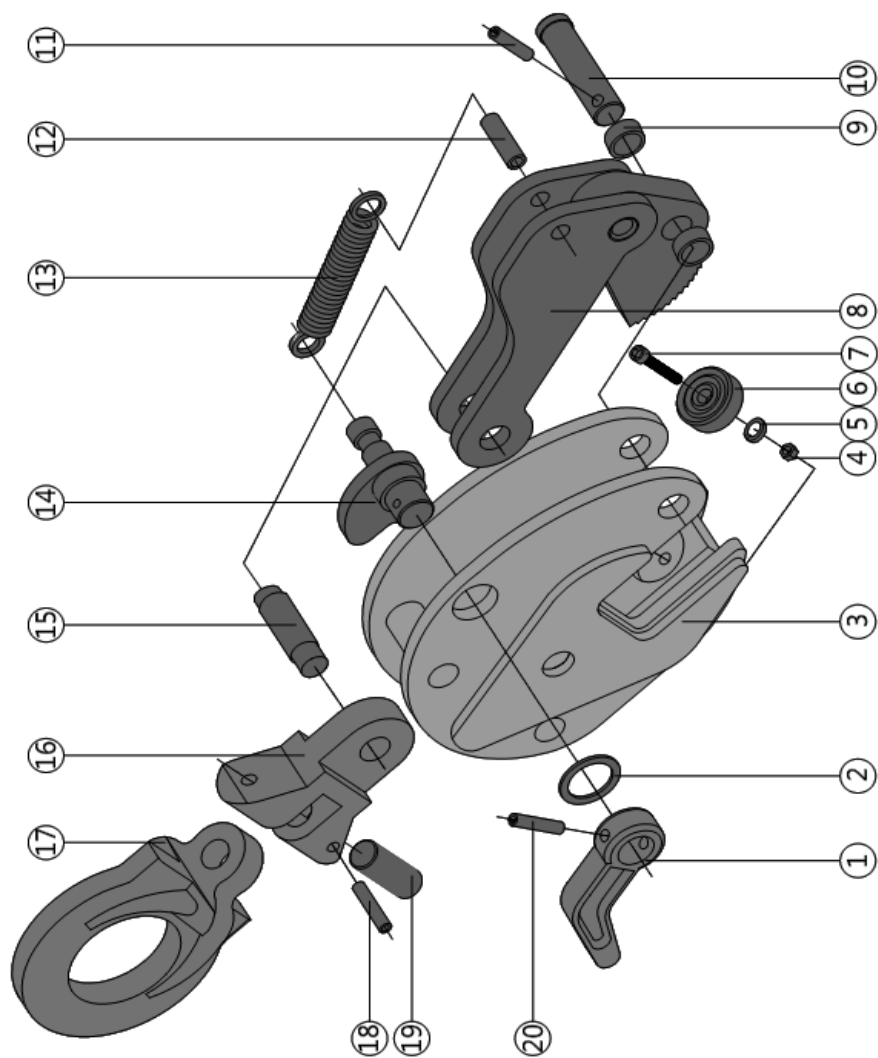

Spare Parts List

No.	Description
1	Wrench
2	Wrench Gasket
3	Casing
4	Nut
5	Spring Washer
6	Round Jaw
7	Inner Hexagon Screw
8	Brake Jaw / Connecting Rod Group
9	Ferrule
10	Main Shaft Pin
11	Elastic Cylindrical Pin
12	Elastic Cylindrical Pin
13	Spring
14	Cam Group
15	Mobile Pin
16	Connector
17	Ring
18	Elastic Cylindrical Pin
19	Connecting Pin
20	Elastic Cylindrical Pin

