

# Operating Instructions & Safety Manual



# Snatch Block Manual

**Rated Capacities  
2 through to 50 tonnes**

**Note: Operator must read and fully understand the operating instructions before using this product.**

Products supplied comply with the essential health & safety requirements of the Machinery Directive 2006/42/EC, the Supply of Machinery (Safety) Regulations 2008 and the Health & Safety at Work etc Act 1974 section 6.

# Safety Information

## OPERATIVE TRAINING

Snatch Blocks should only be used by operatives who have received training in their use and that of the associated equipment when lifting.



Protect yourself and others

## INSTALLATION

1. Prior to installation, inspect the equipment to ensure no damage has occurred in transit.
2. Ensure that the support structure is adequate for the loads that will be imposed (in the case of Snatch Blocks this will also include effort), including an allowance for dynamic loading, has been proof tested & marked with W.L.L. Additionally where this forms a part of, or is, attached to the building structure, ensure that the suitability of the building members for this purpose has been confirmed by a qualified person.
3. When suspending appliances by a hook, ensure the support fits freely into the seat of the hook and does not exact any side thrust upon the point or latch.
4. Product welding can be hazardous and should not be implemented without first seeking instructions from the manufacturer.

## SAFE USE

The basic objectives of any lifting operation is to move the load to the desired location and land it safely, efficiently and without damage to the load, plant, etc. (in addition the following general points should be observed:

- **NEVER** attempt any lifting operation unless you have been training in the use of the equipment concerned.
- **NEVER** attempt to lift/lower more than the rated capacity.
- **NEVER** impose sudden or shock load.
- **NEVER** leave suspended loads unattended, unless in an emergency then ensure that the area is cordoned off.
- **NEVER** use a Snatch Block without legible markings.
- **NEVER** use a worn out or damaged lifting appliance.
- **NEVER** use chain or wire to sling the load.
- **NEVER** lift on the point of the hook.
- **NEVER** force manual equipment to operate, if an abnormally high effort is required this is an indication of a fault or too high a load, check the load and appliance.
- **ENSURE** the load is directly in line with the appliance, DO NOT side load the equipment.
- **ALWAYS** keep clear of the load and DO NOT pass under or ride on the load, DO NOT lift personnel.
- **ALWAYS** avoid swinging loads which can be caused by sudden movement, travel motion or undue effort in pushing the load.
- **ALWAYS** keep fingers and toes clear to ensure they do not become trapped.

## INSPECTION & MAINTENANCE

1. The maintenance programme must meet the requirements of the manufacturers maintenance instructions in addition to any special requirements due to the conditions of service.
2. As a daily routine, the user should visually inspect the block and its associated equipment for obvious signs of damage and report these to the responsible person.
3. It is a further requirement that lifting equipment is thoroughly examined by a competent person at periodic intervals. It should be noted to the Employer any defects found during the thorough examination.
4. All lifting gear should be inspected at least every six months, after any repair, and always before taken into use.
5. When inspecting blocks for wear, check head fitting for deformation gouges, cuts and sharp edges, and any damage which may produce additional stress conditions. Check for excessive wear in pins, side plates, grooves, bushes or bearings. Check security of bolts, nuts and any other locking method, and ensure that during continuing usage cannot vibrate loose. If any defect is found, the equipment must be immediately withdrawn from service.

# Specifications

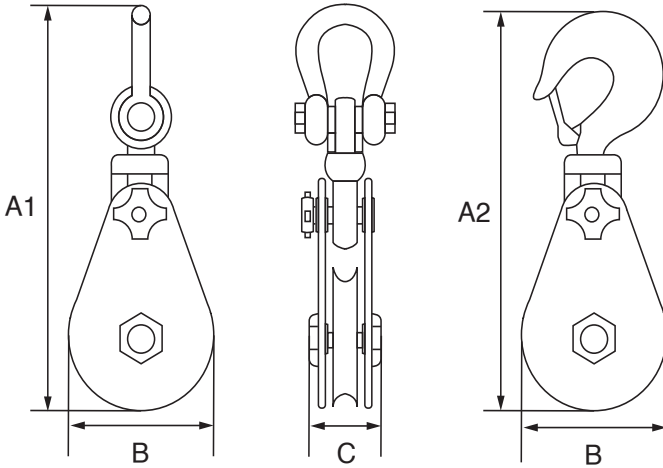

Shackle Head Product Code	Hook Head Product Code	Sheave Dia inch	W.L.L. t	Wire Dia mm	A1 mm	A2 mm	B mm	C mm	Weight kgs
VSBS32	VSBH32	3	2	7 - 9	292	286	82	70	4
VSBS44	VSBH44	4.1/2	4	10 - 12	358	345	120	70	6
VSBS6816	VSBH6816	6	8	16	475	480	160	93	15
VSBS6820	VSBH6820	6	8	20 - 22	498	475	160	93	14
VSBS88	VSBH88	8	8	20 - 22	549	528	210	93	20
VSBS1012	VSBH1012	10	12	20 - 22	701	679	260	114	36
VSBS815	VSBH815	8	15	20 - 22	672	663	210	98	34
VSBS1215	VSBH1215	12	15	24 - 26	797	884	310	133	54
VSBS1422	VSBH1422	14	22	28 - 32	960	952	365	140	112
VSBS1630	VSBH1630	16	30	32 - 35	1085	1126	415	155	170
VSBS2030	VSBH2030	20	30	32 - 35	1177	1256	514	162	213
VSBS2450	VSBH2450	24	50	46 - 50	1445	1525	625	240	408

# Spare Parts List

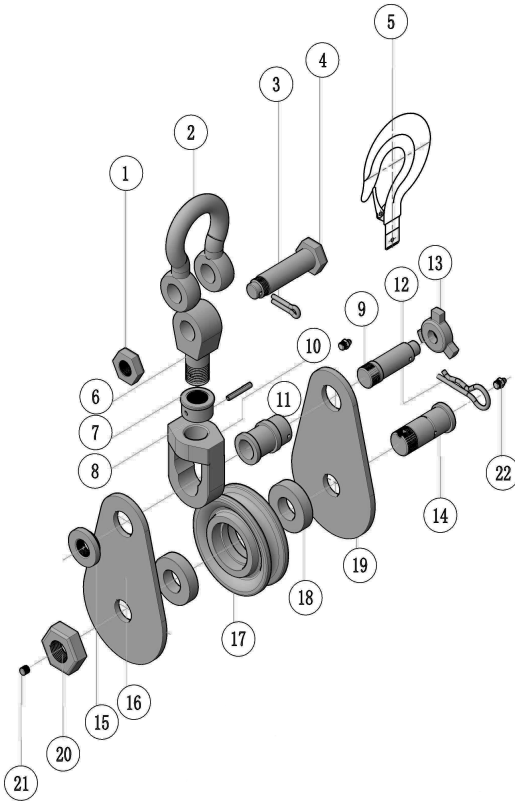

Fig. No.	Description
1.	Nut
2.	Shackle
3.	Split Pin
4.	Shackle Pin
5.	Hook
6.	Fork Eye
7.	Hook Nut
8.	Spring Pin
9.	Axle
10.	Swivel Eye
11.	Tub Wheel
12.	Safety Nip
13.	Handle
14.	Wheel Pin
15.	Plate Nut
16.	Lift Plate
17.	Wheel
18.	Bearing
19.	Right Plate
20.	Wheel Pin Nut
21.	Bolt
22.	Grease Cup