

# Operating Instructions & Safety Manual



## Horizontal Plate Clamp Manual

**Rated Capacities  
1.5 through to 20 tonnes**

**Note: Operator must read and fully understand the operating instructions before using this product.**

Products supplied comply with the essential health & safety requirements of the Machinery Directive 2006/42/EC, the Supply of Machinery (Safety) Regulations 2008 and the Health & Safety at Work etc Act 1974 section 6.



# Safety Information

## GENERAL

This manual contains important information for the correct installation, operation and maintenance of GT Viper Horizontal Plate Clamps. The use of any clamp presents some risk of personal injury or property injury/damage.

All persons involved in such installation, operation and maintenance should be thoroughly familiar with the contents of this manual. To safeguard against the possibility of property damage or personal injury follow the recommendations and instructions of this manual and keep it for further reference.

Aside from transporting plate, this clamp is well-suited to turning over steel structures and welded constructions. They are type tested to 4 to 1 against breakage. Each unit is proof tested to 2 times the rated capacity.



Please note the lock and release button which is situated to the opposite of the label side on the clamp.

**DO NOT** use the clamps in areas containing flammable vapors, liquids, gasses or combustible dust or fibres.

**DO NOT** use the clamp in highly corrosive, abrasive, wet environments or in applications involving exposure to temperatures below  $-40^{\circ}\text{C}$  or above  $+80^{\circ}\text{C}$ .

## INSTALLATION

1. Estimate the plate that is to be lifted or moved and make sure it does not exceed the rated load of the clamp.
2. This clamp with pivoting shackle can be used for lifting and transporting plate at various angles, but the load capacity is reduced, as seen on the diagram below showing the load/force capacities.

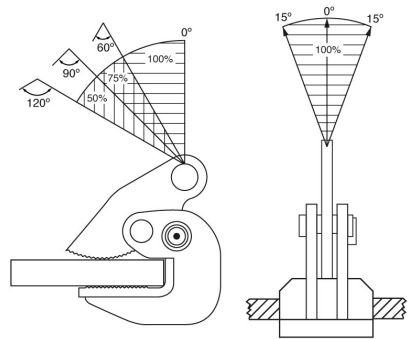

## DIAGRAM OF FORCE

1. When lifting clamps are used for horizontal transport of the clamps, one should observe that the lifting capacity for double leg chain sling is as follows;
  - **Until 60 degs** = 100% of the W.L.L.
  - **Until 90 degs** = 75% of the W.L.L.
  - **Until 120 degs** = 50% of the W.L.L.
2. Make sure that the plate surface has a hardness value below HRC 30/Brinell1300.
3. Make sure that the support to which the pivoting shackle is attached is strong enough to hold several times the weight of the plate.

# Operation & Maintenance

## WARNING

**YOU MUST USE THIS ITEM IN PAIRS**

## WARNING

To avoid damage and/or personal injury:

- Do not exceed maximum load of the clamp.
- Do not use the clamp to lift or transport people.
- Do not use a damaged clamp, if you suspect something is faulty/incorrect with the clamp, immediately take out of service.
- Do not lift or transport loads over people and make sure all personnel remain clear of supported plate.

## OPERATION

1. Place the clamps on the plate and exercise pressure, so that the inner side of the jaw rests against the plate.
2. Tension the cables or chains with the crane hook, while the inner side of the jaw rests against the plate.
3. The load may now be lifted, paying careful heed to maintaining constant tension on the chains and/or cables.
4. As soon as the load is at its destination, let the crane hook descend until the clamp is fully free of load, meaning that the lifting chain/cable is no longer taut.
5. The clamps may now be removed from the load. A crowbar may be used by placing between the ridges of the body, this allows the clamps to be simply turned away under the plate.



## MAINTENANCE/INSPECTION

To maintain continuous and satisfactory operation, a regular inspection procedure must be initiated so that worn or damaged parts can be replaced before they become unsafe.

If faults are detected, the clamp must be put out of service immediately. The intervals of inspection must be determined by the individual application and are based upon the type of service to which the clamp is subjected.

The components of the clamp are to be inspected for damage, wear, corrosion or other irregularities. Repairs may only be carried out by a specialist workshop that uses original spare parts.

- Do not lift plate that is not fully engaged with the clamping jaws.
- Do not leave load support by the clamp unattended unless specific precautions have been taken.
- Do not lift loads that are not balanced, and the holding action is not secure.
- Make sure of the condition of the load to be lifted.
- Be sure to stay clear of the swinging range of objects being lifted.

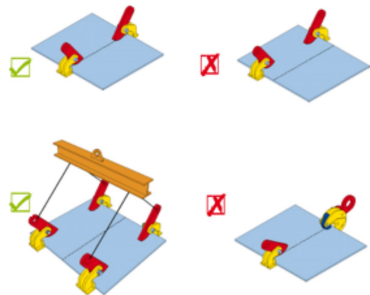

# Spare Parts & Specification

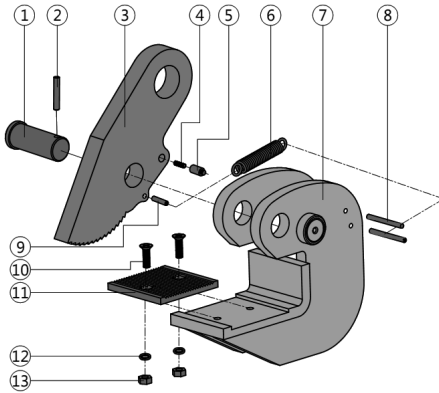

1.	Main Shaft Pin
2.	Elastic Cylindrical Pin
3.	Brake Knife
4.	Pressure Spring
5.	Elastic Pin
6.	Tension Spring
7.	Casing
8.	Elastic Cylindrical Pin
9.	Elastic Cylindrical Pin
10.	Flat Head Screw
11.	Toothed Plate
12.	Spring Washer
13.	Locknut

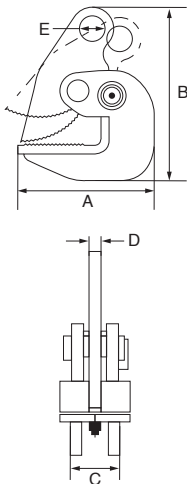

Product Code	Capacity per pair kgs	Jaw Opening mm	A mm	B mm	C mm	D mm	E mm	Weight kgs
VHPC1.5	1,500	0 - 25	125	175	38	14	22	2.5
VHPC2	2,000	0 - 30	155	205	38	16	25	3.5
VHPC3	3,000	0 - 30	158	205	42	16	25	4
VHPC4	4,000	0 - 40	180	252	46	18	30	5
VHPC5	5,000	0 - 45	185	252	50	18	30	6
VHPC6	6,000	0 - 45	185	252	50	18	30	6
VHPC8	8,000	0 - 50	180	260	52	18	30	6.5
VHPC10	10,000	0 - 55	185	260	56	20	30	7.5
VHPC12	12,000	0 - 65	210	308	62	22	37	10.5
VHPC16	16,000	0 - 100	282	400	65	25	55	22
VHPC20	20,000	0 - 125	325	500	75	28	55	33