

## Closed Body Rigging Screw Jaw/Eye – RSJE

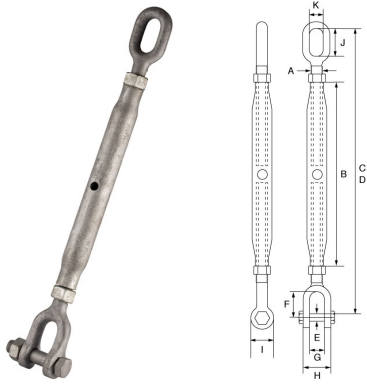

# GT

- Mild steel.
- Hot dipped galvanised finish.
- Proof load tested to 2 times the W.L.L.
- Minimum breaking load is 5 times the W.L.L.
- Metric Threads.
- Marked with CE, W.L.L, manufacturers ID and traceability code.
- Certification available **2.1** **DoC**

Product Code	W.L.L.	A	B	C	D	E	F	G	H	I	J	K	Weight
	t	mm	mm	mm	mm	mm	mm	mm	mm	mm	mm	mm	kgs
RSJE6	0.2	6	100	170	248	M5	19	7	20	13	11	11	0.132
RSJE8	0.32	8	108	189	273	M6	25	9	24	14	12	12	0.23
RSJE10	0.5	10	125	216	306	M8	26	10.5	28	19	13	13	0.38
RSJE12	0.7	12	195	323	478	M10	32	13	34	22	30	15	0.78
RSJE16	1.2	16	230	384	569	M12	39	18	42	28	40	20	1.36
RSJE20	1.5	20	270	455	665	M16	46	20	51	33	50	24	2.33

Product Code	W.L.L. t	A mm	B mm	C mm	D mm	E mm	F mm	G mm	H mm	I mm	J mm	K mm	Weight kgs
RSJE22	2.2	22	295	493	723	M20	55	25	55	38	50	24	3.01
RSJE24	3.2	24	325	552	802	M22	63	30	70	46	56	28	4.1
RSJE33	4.8	33	370	673	963	M30	85	38	82	60	70	35	9.23
RSJE39	6	39	400	718	1018	M33	86	45	85	76	80	40	11.1
RSJE45	8.5	45	400	760	1050	M39	105	50	100	86	90	45	20.8
RSJE48	11	48	400	820	1110	M45	120	58	118	92	100	45	24