

Building the Flak 38

Step 1: Glue the hand cranks to the base plate and the left frame.

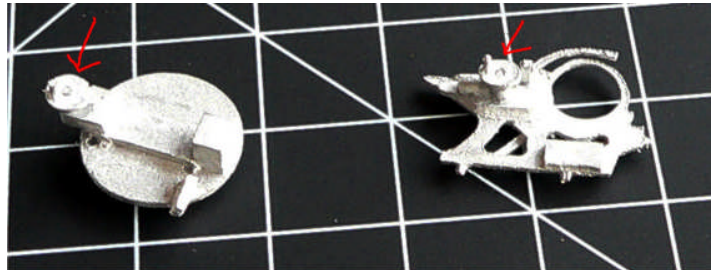

Step 2: Glue the left frame to the base plate using the two pins and guide holes for position

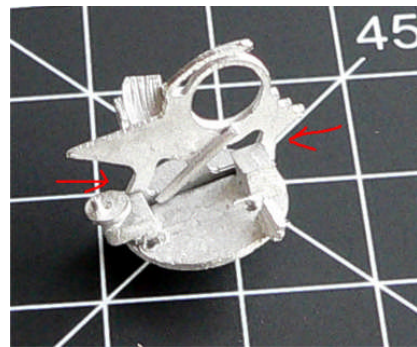

Step 3: Locate the solid semi circle of the barrel assembly inside the circular ring of the left frame. Glue the right frame to the base plate, locating the barrel assembly inside the circular ring and again use the two pins and guide holes for position. If you want the gun barrel to raise and lower do not glue the barrel assembly to the rings.

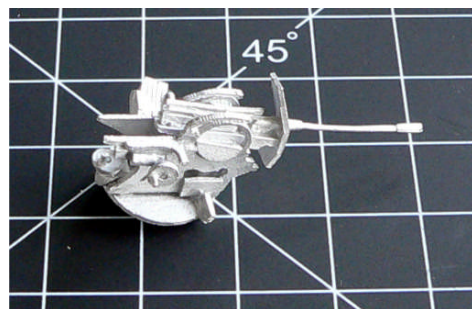

Step 4: Glue the gun shield onto the frames using the two pins and guide holes for positioning.

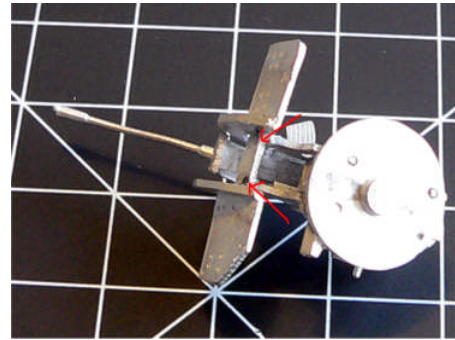

Step 5: Glue the Gunner's shield onto the left frame.

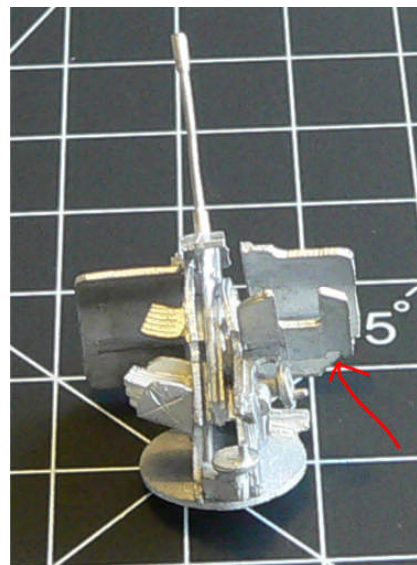

Step 6: Glue the range finder group on the rear of the left and right frames using the notches on the group for location.

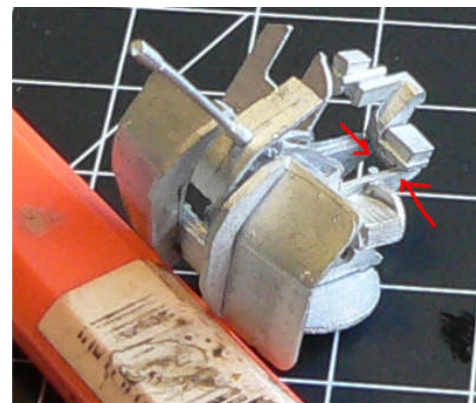

Step 7: Glue the gunner's seat or the seated gunner figure to the base plate. Place the completed gun onto the base. Do not glue if you want the gun to traverse.

There you have it.

