



Live
technical
support

+44 (0)1691 655150



SKU: CP-ASFRV

Modular Traffic Light - 24V - Black Body - Red/Green LED Lens

Dimensions

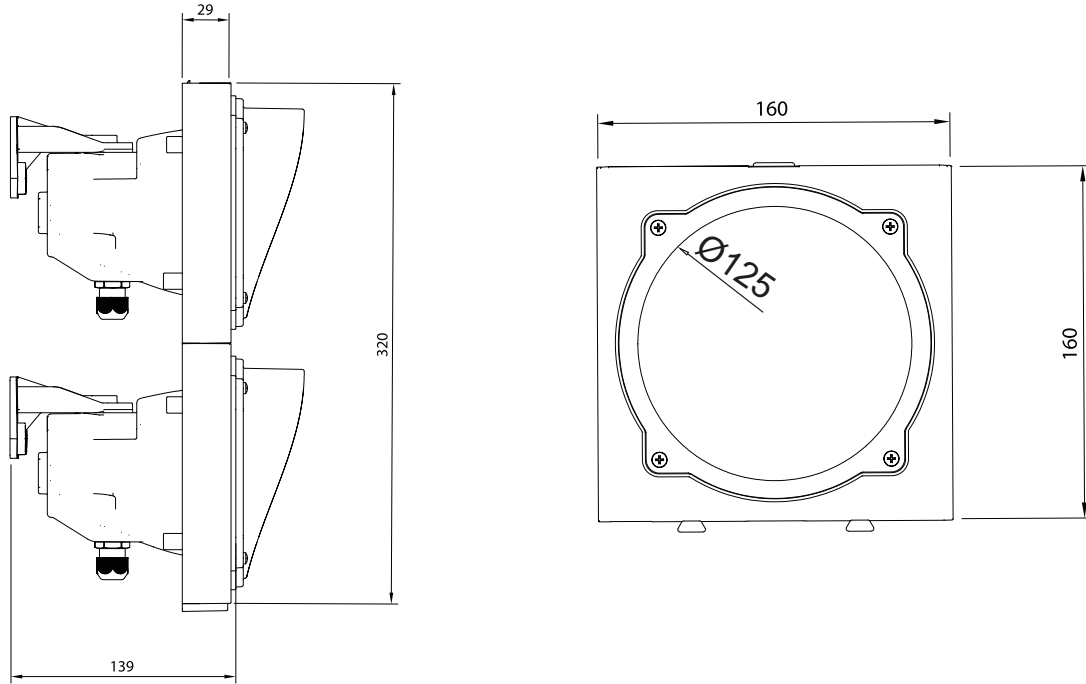

Modularity

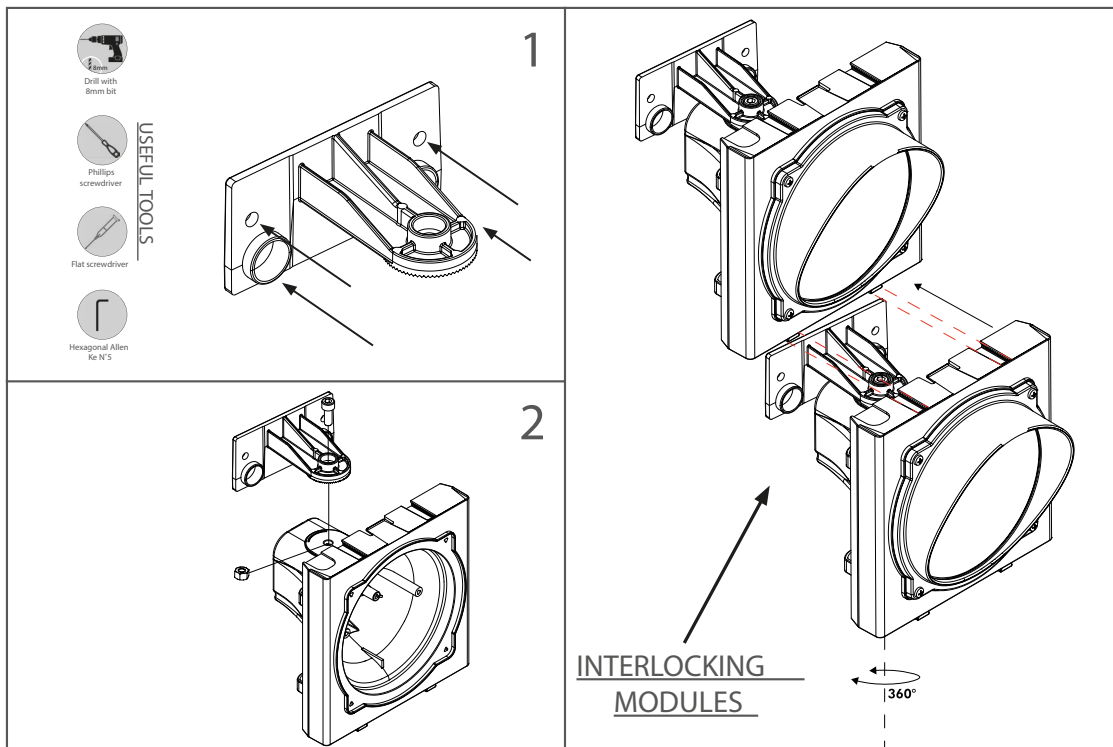



+44 (0)1691 655150



SKU: CP-ASFRV

Modular Traffic Light - 24V - Black Body - Red/Green LED Lens

Wiring

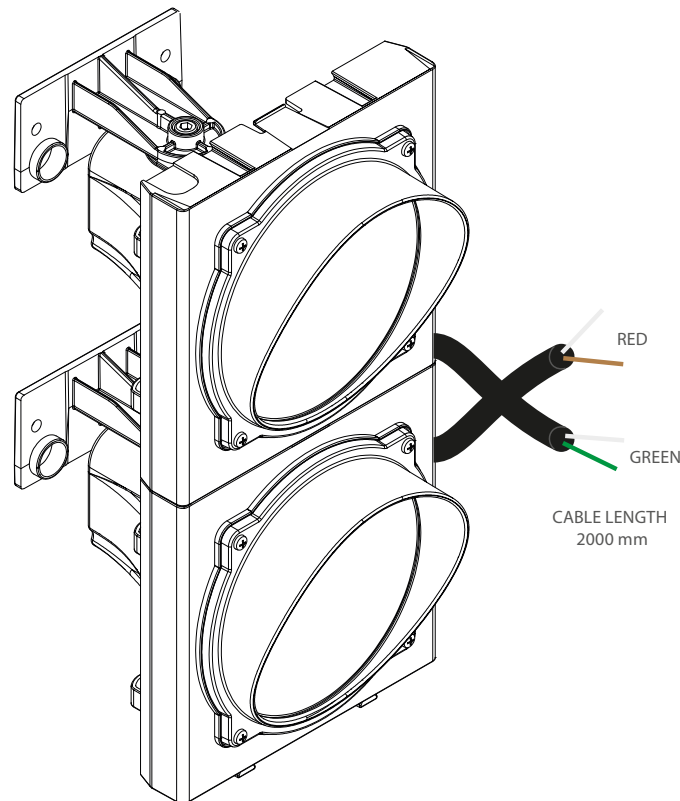

Disposal

The packaging components, cardboard, or plastic can be recycled through separate collection. In the case of disposal of the product on the other hand need to pay much attention to components that may contain pollutants such as circuit boards, remote control batteries etc., which must be recovered or

disposed of in special centres or at authorized facilities. In this case it is necessary to refer to the specific regulations in force in the place of disposal.

The crossed-out waste bin symbol on the appliance or on its packaging means that at the end of its useful lifespan, having to be treated separately from household waste, it must be taken to a separate collection centre for electrical and electronic equipment. Otherwise, the user can return it to the retailer at the time of purchase of a new type of equivalent appliance.

The user is responsible for providing the appliance at the end of its life to the appropriate

collection facilities. The appropriate separate collection to permit the consequent recycling, treatment and environmentally compatible disposal helps prevent negative impact on the environment and

human health and promotes the recycling of the materials making up the product. For MORE detailed information regarding the collection systems available, contact the local waste disposal service or the shop where the purchase was made.