

# 2 template kit for wheel unit fixing

## RG-20

Template kit for wheels fixation  
 Kit de gabarit pour la fixation des galets  
 Rädern Befestigung Schablone Kit  
 Kit de plantilla para fijación de ruedas  
 Комплект шаблонов выравнивания для колес

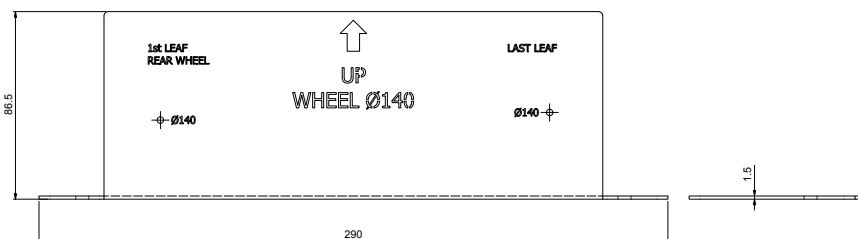
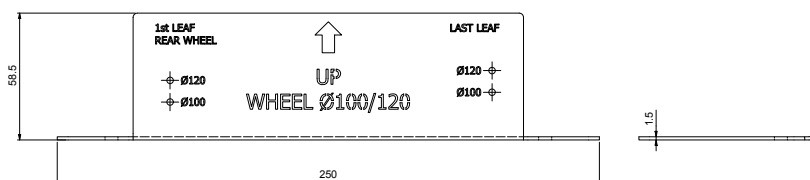

CODE	ART.	Box info	
		Pcs per pack	Kg
10131102 001	RG-20	1	0.9



**1** Using the template mark the area to cut and drill

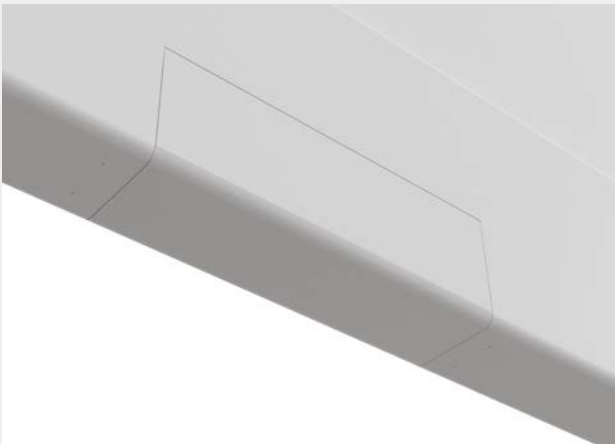

**2** The tubular section is marked

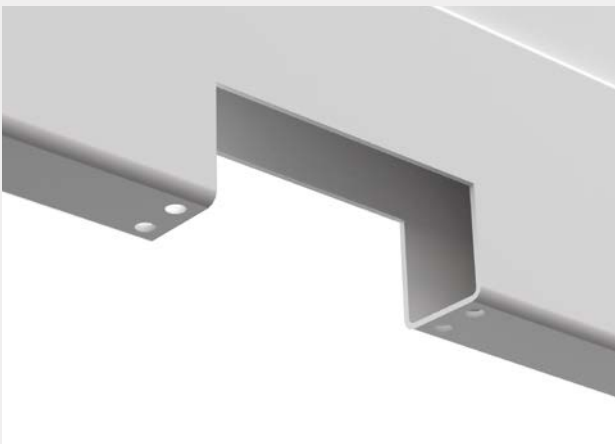

**3** Cut and drill the tubular section



**4** Fix the drive wheel