



Datasheet CCT Team Pro Disc

For more informations visit www.corratec.de



CCT Team Pro Disc

Weight from: 7,90 kg

Frame: Corratec CCT Team Disc

Components: Shimano Ultegra Di 2 11S

Size: 46, 48, 51, 54, 57, 60

Colors:



TECHNOLOGIES



PRO SIZE SYSTEM



PRO CONTROL FORK



LOW PROFILE CHAINSTAY



WHEEL SIZE



SUPER LIGHT



EPS CARBON



INTERNAL CABLE ROUTING



TAPERED HEADTUBE

DESCRIPTION

Perfect for long and challenging road bike tours. The Ultegra Disc Brake offers an even higher level of control and safety, therefore riders benefit from the highest Breaking performance.

Combined with the comfortable and sporty Carbon frame: A real all-rounder!

- Light and reliable Mavic Akisium wheels
- Elektronik Shifting with Shimano Ultegra Di 2
- Shimano Ultegra Disc Brake for maximum breaking performance

FRAME

CM	A	B	C	D	E	F	G	H
46	519	121	71	75	976	407	375	520
48	537	133	73	74	976	407	383	536
51	555	149	73	74	982	407	391	554
54	570	160	73	73	992	407	398	564
57	589	182	73	73	1009	407	408	586
60	604	203	73	73	1109	407	418	606

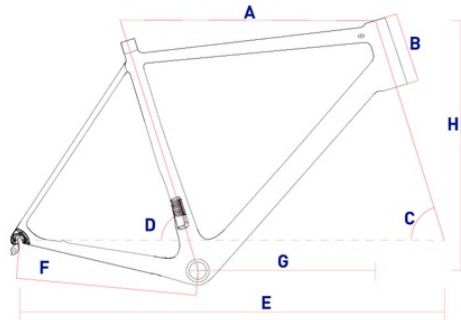

EQUIPMENT

MAIN:

FRAME:	Corratec CCT Team Disc
FORK:	Corratec Pro Control Disc Fork
BREAKES:	Shimano Ultegra hydraulic Disc Brake front Shimano Ultegra hydraulic Disc Brake rear
STEM:	ZZYZX SL Alloy
HANDLE BAR:	ZZYZX SL Alloy Handlebar
SADDLE:	Fizik Antares R7
SEAT POST:	ZZYZX Twin Bolt

WHEELSET :

RIM:	Mavic KSYRIUM Disc
TIRE:	Continental Grand Prix 4000S II

DRIVE:

CHAINWHEEL:	Rotor Vestag Spider
CASSETTE:	Shimano ULTEGRA
FRONT DERAILLEUR:	Shimano ULTEGRA Di2
REAR DERAILLEUR:	Shimano ULTEGRA Di2 11s
SHIFT LEVERS:	Shimano ULTEGRA Di2

SPECIAL:

CHAINWHEEL RATIO:	2s; 50/34
CASSETTE RATIO:	11s; 11-12-13-14-15-17-19-21-23-25-28
SIZE BRAKE DISC	160 mm front 160 mm rear

