



Datasheet Revolution iLink Elite

For more informations visit www.corratec.de

Revolution iLink Elite

Weight from: 12,8 kg kg

Frame: Corratec Revolution iLink

Components: Sram NX Eagle 12S

Size: 44, 48, 52

Colors:



TECHNOLOGIES



DESCRIPTION

The new trailfully with 29 inch wheels will be available with a full carbon frame. The frame is equipped with the proven Inside Link technology. Equipped with 120 mm front and rear travel and a Vario seat post by Kindshock. You looking for a bike to enjoy uphill riding pleasure and still have lots of fun on your downhill? This is the perfect bike for you!

- Sram NX Eagle shifts reliably and precisely.
- Rockshox REBA RL 120mm provides riding comfort and control on trails.

FRAME

CM	A	B	C	D	E	F	G	H
44	589	101	68	75	1144	435	445	610
48	616	108	68	75	1171	435	460	615
52	632	124	68	75	1192	435	475	630

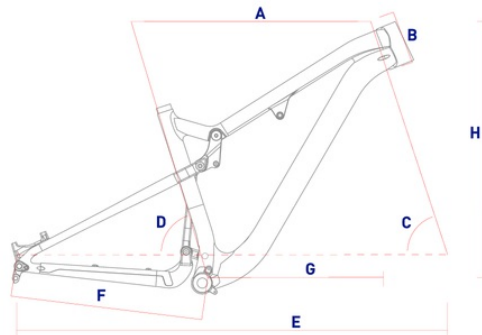

EQUIPMENT

MAIN:

FRAME:	Corratec Revolution iLink
FORK:	Rockshox REBA RL
FULLY DAMPER:	Fox 2019 FLOAT DPS Factory
BREAKES:	Shimano Disc Brake MT400 front Shimano Disc Brake MT400 rear
STEM:	ZYZX SL Alloy
HANDLE BAR:	ZYZX SL Alloy Handlebar
SADDLE:	Selle Italia X3
SEAT POST:	Kindshock E20i OD

WHEELSET:

RIM:	ZYZX Cross Attack 29 Boost
TIRE:	Schwalbe Nobby Nic

DRIVE:

CHAINWHEEL:	SRAM NX Eagle Boost Black
CASSETTE:	SRAM PG1230 Eagle
REAR DERAILLEUR:	SRAM NX Eagle
SHIFT LEVERS:	SRAM NX Eagle

SPECIAL:

CHAINWHEEL RATIO:	1s; 32
CASSETTE RATIO:	12s; 11-13-15-17-19-22-25-28-32-36-42-50
FORK SUSPENSION TRAVEL:	120 mm
FULLY SUSPENSION TRAVEL:	120 mm
SIZE BRAKE DISC:	180 mm front 180 mm rear

