

# Right-Brained Place Value

Multiple-digit addition and subtraction made easy



a **Forget Memorization** book

*Effortless learning through images, stories, hands-on activities, and patterns*

by Sarah Major



[www.child1st.com](http://www.child1st.com)

Right-Brained Place Value

© 2013 Sarah Major

ISBN: 978-1-936981-55-7

Printed in the United States of America

All rights reserved. The reproduction of any part of this book for an entire school or school system or for commercial use is strictly prohibited. No form of this work may be reproduced, transmitted, or recorded without written permission from the publisher.

**Reproducing Pages from This Book**

The pages in this book bearing a copyright line may be reproduced for instructional or administrative use (not for resale). To protect your book, make a photocopy of each reproducible page, then use that copy as a master for future photocopying.

To request more information regarding the copyright policy, contact:

Child1st Publications

800-881-0912  
info@child1st.com

For other teaching and learning resources designed for visual, tactile, kinesthetic and other right-brained learners, visit [www.child1st.com](http://www.child1st.com).

Other books and materials by this author:

*Alphabet Tales*

*The Illustrated Book of Sounds & Their Spelling Patterns*

The Easy-for-Me™ Books, sets A and B

The Easy-for-Me™ Reading Program

Kid-Friendly Math Series

*Right-Brained Multiplication & Division*

*Right-Brained Addition & Subtraction*

*Writing the Visual, Kinesthetic and Auditory Alphabet*

SnapWords® sight word cards and SnapLetters™ stylized alphabet

*I Can Sing from 1 to 10*

*SnapWords® Spelling Dictionary*

## ABOUT THIS BOOK

This book is for children who are strongly visual, who learn all at once through pictures, are drawn to patterns, rely on body motions, and who need to understand the process behind each math problem they solve. Child1st teaching and learning resources all follow the principle of conveying teaching using a variety of right-brain-friendly elements. We take learning concepts that utilize symbols (numbers and letters) and abstractions, which are left-brained, and embed them in right-brained elements to beautifully integrate the left and right hemispheres in the brain.

### Right-brained Elements:

- 1- We embed symbols in **VISUALS** so that the child can take a quick look, absorb the learning piece, and store it as an image to be retrieved intact later.
- 2- We use **PERSONIFICATION** which is a powerful element in teaching and learning. The use of personification makes for rapid learning because the very look and personality of the character conveys the substance of the learning. For example, in this book, dot patterns take on the characters of a bear's face, a high chair, a row of bushes, etc.
- 3- We rely on **PATTERN DISCOVERY** as a way of making numbers come alive and as a means of conveying the amazing relationships between numbers. What results is number sense. Because the brain is a pattern seeking organ, it is drawn to material that follows patterns. It is my desire that through this teaching resource, many children who are overwhelmed or daunted by math might come to truly be fascinated by it instead.
- 4- We use **STORY** to contain and convey the meaning of what we are teaching. Stories, like visuals, make learning unforgettable. They explain the “why” behind math concepts and tie everything together, creating a vehicle for meaning and for recall.
- 5- We use **BODY MOTION**—both gesture and whole body movement that mirrors the symbol shape or the action in the math story (such as addition or subtraction). Again, body movement is a powerful agent for learning and remembering. For many people, body motion makes recall effortless if the idea in the lesson is directly tied to a unique motion.
- 6- We employ **VISUALIZATION**—a powerful tool for right-brain-dominant learners. If these learners are given time to transfer the image on the paper in front of them to their brains (prompt them to close their eyes and SEE it in their mind's eye), they will be able to retrieve that image later. If the image contains learning concepts, this is how they will remember what you want them to learn. So in this book, each time a visual is introduced, prompt the student(s) to “see” the image in their mind, eyes closed.

## HOW TO USE THIS BOOK

Because this book builds on *Right-Brained Addition & Subtraction* (or Book 1), please familiarize yourself with Chapters 2-4 of that book first, including “Good Practice,” “Assessments,” “Visual Imprinting,” and “Learning Numbers.” You should also be familiar (from Book 1) with the 5-Frames, “My Two Hands,” and Stony Brook Village.

**For students just finishing Book 1**, who are fluent with computation to 10, skip to Chapter 3 to begin new material.

**For students unfamiliar with Right-Brained computation**, teach Book 1 Chapters 5-7 before beginning this book.











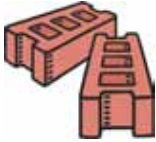

**For students needing a review of Book 1**, skip to Chapter 2 for a quick review of Book 1. Make sure the children are completely fluent with computation to 10 before beginning this book.

**For remediation**, determine whether the students lack skills in computation to 10. If they do, use Chapter 2 of this book first, or if they need more practice, use Book 1, Chapters 5-7.

# TABLE OF CONTENTS

About This Book .....	3
How To Use This Book .....	3
Global View of Right-Brained Place Value .....	4
Table of Contents .....	5
Chart of Learning Styles .....	6
Stony Brook: Global View of Computation to 10 .....	7
Introduction .....	9
Chapter 1 - How Children Learn .....	11
Chapter 2 - Prerequisite Skills .....	15
Chapter 3 - Place Value .....	21
Chapter 4 - Computation Using Place-Value Mats .....	26
Chapter 5 - A Bird's Eye View .....	36
Chapter 6 - Make a 10 .....	40
Chapter 7 - Take from 10 .....	46
Chapter 8 - Taking Stock .....	52
Chapter 9 - To the Top! .....	56
Appendix A - Activities & Resources .....	67
Appendix B - Monitoring & Tracking Forms .....	206
Appendix C - Answer Keys .....	216

# CHART of LEARNING STYLES

Traditional Methods are	
designed for these learners	but not for these learners!
<b>How do I learn? (Dr. Anthony F. Gregorc)</b>	
<b>I perceive the world</b>	
<p><b>Concrete</b> I use my senses to take in data about the world. What I see is what is real to me.</p> 	<p><b>Abstract</b> I visualize, intuit, imagine, read between the lines, and make connections. I pick up subtle clues.</p> 
<b>I order the information I perceive</b>	
<p><b>Sequential</b> I organize my thoughts in a linear, step-by-step manner. I prefer to follow a plan.</p> 	<p><b>Random</b> I organize my thoughts in segments. I will probably skip details and even whole steps, but I will still reach the goal. I like to make up my own steps.</p> 
<b>How do I remember? (Raymond Swassing &amp; Walter Barbe)</b>	
<p><b>Auditory</b> I listen to directions. I need to hear the sounds.</p> 	<p><b>Visual</b> I need to see it. I make visual associations, mental maps or pictures, and see patterns.</p>  <p><b>Kinesthetic</b> I remember well what I learn through my body. I learn best by actually doing the job.</p> 
<b>How do I understand? (Herman Witkin)</b>	
<p><b>Analytic</b> I am good with details, can follow steps and hear instructions, and like to finish one thing at a time.</p> 	<p><b>Global</b> Show me the big picture! I need to see how all the parts fit in. I can hear directions after you show me the goal.</p> 
<b>How am I smart? (Howard Gardner)</b>	
<p><b>Verbal/Linguistic</b> I am verbal! I can speak, write, debate, and express myself well through words. IQ tests love me!</p>  <p><b>Logical/Mathematical</b> I rely heavily on my logic and reasoning to work through problems. I am a whiz on standardized tests.</p> 	<p><b>Visual/Spatial</b> Show me a map and I'll have it! I make vivid mental images and can use these to recall associated information. I want to see how something fits into its environment or surroundings.</p>  <p><b>Body/Kinesthetic</b> I combine thinking with movement. I do well with activities that require precise motions. I learn by doing; my attention follows my movements.</p> 

In Stony Brook Village, just over the brook from the residential area, there is a town square with office buildings all around it. Each building is new and clean and shaded by big trees. Pointed roofs crown each building, and attic numbers (1 and 10, which represent place value) are painted on the attics like this. (Show an overhead of the empty buildings; use 3.1 on page 91.)

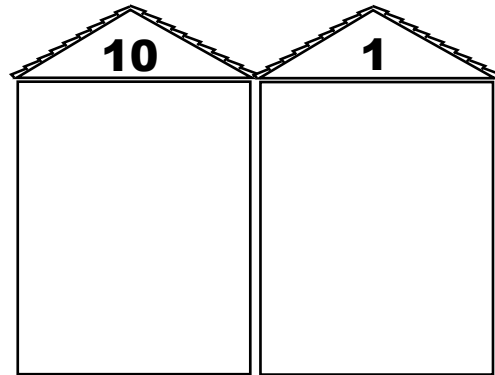

The planning commission has hired you as the property manager for one of the office buildings, and it is your job to rent office space to people who want to work inside your building. (Point to the side of the building labeled 1.) There are nine desks in this office. That means on this side you can rent desks to nine people, and no more. (Point to the side labeled 10.) On this side are big tables, each seating ten people. (Note: In this context the 10 and 1 represent place values, not a numerical total of the number of workers.)

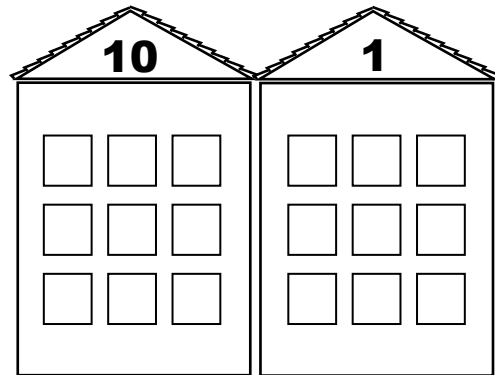

Ten people exactly—no more, no less—must sit around each table. Once you have rented all the desks on the 1s side of the building, if more people come in looking for a place to work, you will need to take ten people from the 1s side and move them over to a big table on the 10s side. Then you can fill up the desks on the 1s side again. Each time you get ten or more people on the 1s side, you have to move a group of ten next door. If you don't, and you leave too many people on the 1s side, the commission will hear about it, and they will come with their sirens screaming to give you a ticket!

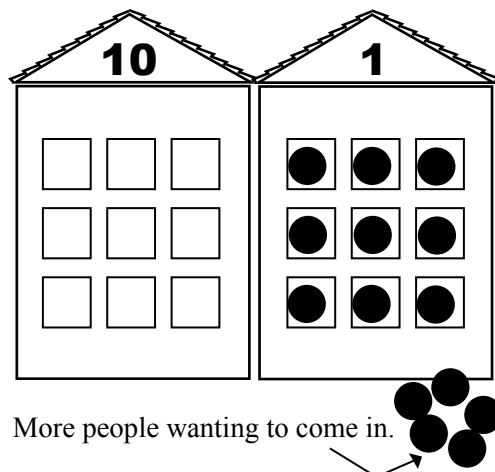

## ACTIVITIES FOR PLACE VALUE

**Act it out:** Use masking tape to outline on the floor the two sides of the office, large enough that ten children can actually fit inside. (Make sure the 10s side is on the left, to mirror the order of the 10s place and 1s place in a written number.) Place nine chairs inside the 1s office and leave the 10s side empty. Tell a story in which you come to the office one day, unlock the door, and soon three children arrive, wanting to rent desks. Have three volunteers step forward, welcome them, and show them to their desks. Continue adding more occupants until the children tell you that you have reached the magic number of ten. Then have the class work out what to do next—don't tell them; let them talk it out. At this point introduce the phrase “make a ten,” which you will use repeatedly throughout the method. Usher a group of ten next door, then take a large satin ribbon and gently tie the children together so they represent a group. They will not forget this object lesson! During the game, you want to reinforce the pattern of filling up the 1s side first; then, when the side fills up, making a group of ten and moving the group of ten next door. The motion is “in and to the left,” which will be mirrored in written computation.

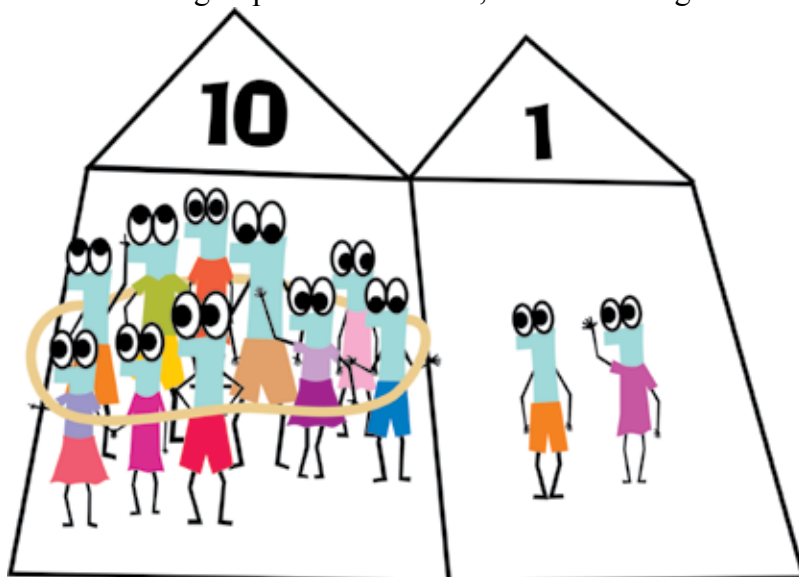

**Rent-an-office game:** This is a good game for children to play in the math center.

Reproduce and laminate the game cards 3.2 (pages 92-93). Also photocopy the place-value mats 3.3a–b (pages 94-95). Place the two pages of 3.3 side by side and photocopy or glue onto 11” x 17” paper (making sure the 10s side is on the left). Either a pair or small group of children can play. Give the children a handful of rubber bands and a pack of wooden craft sticks. The children take turns drawing a game card and placing the corresponding number of craft sticks (“workers seeking office space”) on the 1s place mat (the “office building”). As soon as the number of craft sticks exceeds nine, the children count out ten sticks, bundle them with a rubber band, and move them over to the 10s place-value mat. The purpose of this game is to practice the action of bundling (“making a ten”) and then moving the bundle of ten next door. Encourage children to continue playing until they are fluent with the actions of bundling and moving sticks to represent the concept of place value.

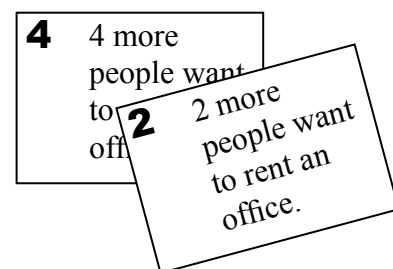
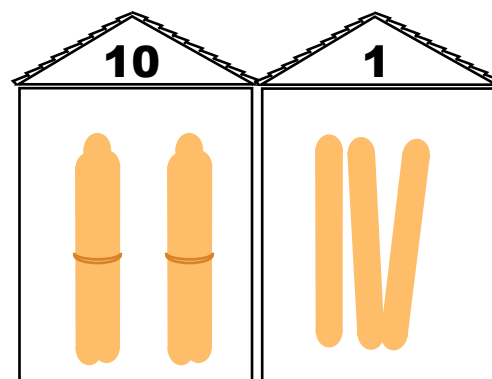

*Place-Value placemats showing single and bundled sticks, and Rent-an-Office playing cards.*

they learn to add numbers with sums larger than 10. First they check the 1s side to determine if they need to make a ten or not, and if they do, they move to the left and place the ten. When they say the number, however, they will name the 10s first, then the 1s. The movement is like the shape of a backwards numeral 7. Illustrate by drawing on the board or on your overhead, as shown in the picture to the left.

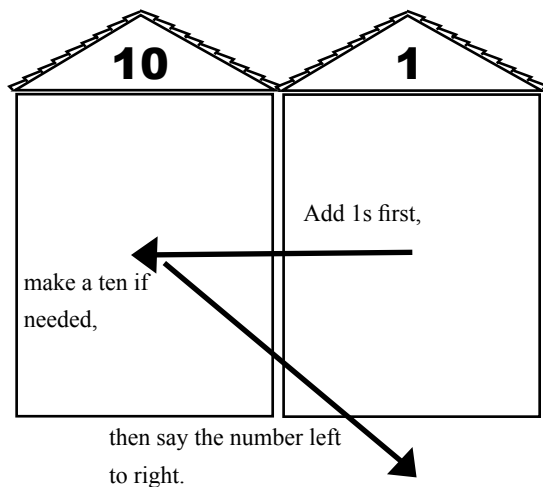

*Now continue the story: "I hear the bell again! This time there are five people coming in the door! Where will you put them? Is there room on the 1s side?"* Then lead them to reassess the number in the offices now to see if they need to "make a ten" (No.  $11 + 5 = 16$ ).

Continue the story, modeling simple addition through the actions of "come in, make a ten, and move to the left" until you observe that the children no longer stop to ponder where to put their "people" and that they make 10s automatically. When they can do this confidently, it is time to move to the next section.

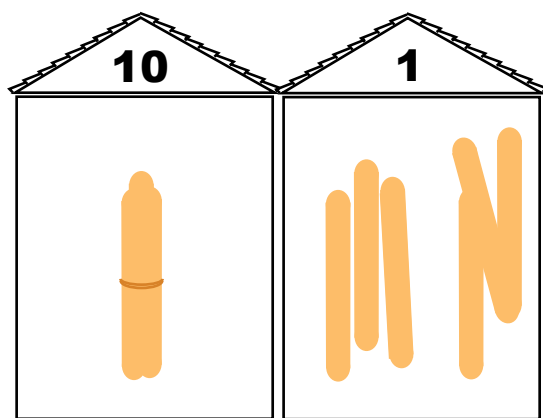

## Activities for Math Centers

**Ten and more dot cards:** Copy double-sided activity 4.1 (pages 103-104). Have children quiz each other about what number is represented by each dot card. (One child holds up a card, and the other child gives the answer.) For example, for 15, the child would say, "One 10 and five 1s." (Note that the ten shaded dots represent one bundle of ten.) If you photocopy the numbers on the back side of the dot cards, the

partner holding up the card can see the answer. If you make duplicate sets of cards, two pairs of students can use them at the same time. These cards can also be used for oral computation. After the child identifies the number represented, you could ask, "What would you have if I gave you three more? What would you have if I took four away?" and so forth.

**1s-place addition cards:** The four double-sided pages of 4.2a-d (pages 105-112) contain simple sums that involve adding only in the 1s place, without having to make a ten. Using their place-value mats and craft sticks, children can build the top number, then add sticks to represent the bottom number in order to determine the sum. They can also take turns drawing a card and solving the problem mentally. Because the answers are printed on the back, these cards are self-assessing if you copy both sides. If students need a prompt, encourage them to check their hands for the answer, rather than resorting to counting up. Children who become reliant on counting with their fingers have difficulty progressing beyond this strategy. Ignoring the 10s column, students can use "my two hands" to determine the total in the 1s column.



(For more advanced problems, they can use “my two hands” one column at a time.) The beauty of this method is that children never need to master facts over ten in order to solve any problem. (For a visual, see page 34.)

**1s-place subtraction cards:** The four double-sided pages labeled 4.3a-d (pages 113-120) are basic subtraction problems that do not require taking from the 10s place. Laminate and cut apart the cards, then use them as described in the previous paragraph for addition cards. (For a visual, see page 34.)

**Make-a-ten addition cards:** The sums in double-sided activities 4.4a-b (pages 121-124) require making a ten. It will be important to introduce these problems using the place-value mats. First the child would arrange sticks to represent the top number of the problem on the mat, then add the appropriate number of sticks to the bottom number of the problem. Remind the children, if necessary, that they need to “make a ten” by taking sticks from the 1s side to add to the new sticks in their hand, make a ten and place it in the 10s office. Then they can clear the mat, draw another card, and build the next problem.

## SUBTRACTION, OR “TAKE FROM TEN”

Start with the children’s place-value mats set up with 16 sticks (one 10 and six 1s) on them. (If you are continuing the lesson from the end of the story on page 22, there will already be 16 sticks on the place mats, or you could do a short addition story leading up to this sum.) As always, I use a story to introduce the new concept of “take from ten” when there are not enough sticks in the 1s office to subtract from there.

### “Take from Ten” Story

*You walk in the office door one morning and find that the air conditioning has broken and the office is hotter than hot! You choke and gasp and can hardly breathe! Just then five of the people start griping and complaining about how hot they are. You assure them you are going to fix the problem immediately, but they announce that they are leaving! They simply cannot work in that heat! You ask them to be patient, that you will work hard and fast to fix the problem, and soon the office will be nice and cool again. But they will not be consoled. They take their things and leave.*

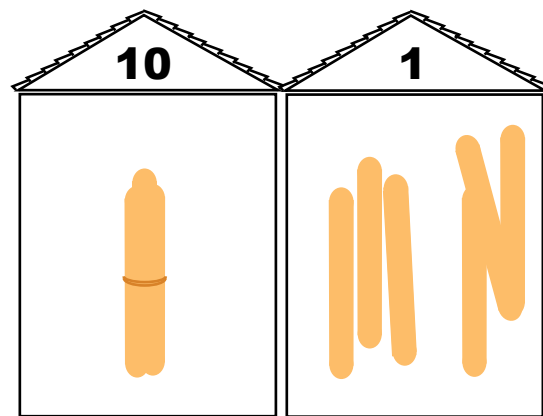

**Processing:** Ask the children where they would take the five people from. Guide them to look at the 1s side first. You want to build a habit of checking the 1s side first to determine whether there are enough people there from which to subtract the whole number.

**Action:** Having verified that there are enough people on the 1s side from which to take five, have the class do so together.

be used with dry-erase markers many times. The teaching procedure works through one section at a time, beginning with oral, small-group discussion and discovery, then moving to written practice. I recommend having the students sit as close to you and the chart as possible, to maximize focus and engagement. The blue part of the chart are all the problems that can be solved without disturbing the 10s. For example, in the column with 14 in the attic, you can subtract 14-14 by just subtracting straight down, 10-10 and 4-4. Likewise, you can subtract 14-13 by simply subtracting 10-10 and 4-3. This means that the children already know how to solve all the problems in blue simply by using their knowledge from 10th Street from the book *Right-Brained Addition & Subtraction*. For right-brained learners, showing them a chart like this is valuable. They will be able to see what they know and what they need to learn.

10		11		12		13		14		15		16		17		18		19		20	
0	10	0	11	0	12	0	13	0	14	0	15	0	16	0	17	0	18	0	19	0	20
1	9	1	10	1	11	1	12	1	13	1	14	1	15	1	16	1	17	1	18	1	19
2	8	2	9	2	10	2	11	2	12	2	13	2	14	2	15	2	16	2	17	2	18
3	7	3	8	3	9	3	10	3	11	3	12	3	13	3	14	3	15	3	16	3	17
4	6	4	7	4	8	4	9	4	10	4	11	4	12	4	13	4	14	4	15	4	16
5	5	5	6	5	7	5	8	5	9	5	10	5	11	5	12	5	13	5	14	5	15
		6	6	6	6	6	7	6	8	6	9	6	10	6	11	6	12	6	13	6	14
						7	7	7	7	7	8	7	9	7	10	7	11	7	12	7	13
										8	8	8	8	8	9	8	10	8	11	8	12
														9	9	9	10	9	11	9	12
																		10	10	10	11
																				10	10

## STEP 1: PATTERN DISCOVERY

1. Display the chart and encourage the children to share what they notice. Allow plenty of time for them to reflect. Record their responses.

2. Focus on the 10s column, since the children are fluent with these problems. Point out that the ten is the attic number for this building. Explain to them that Stony Brook Village was growing so fast that the planning commission decided to build apartment buildings. Each building has an attic number, and each floor in the building has exactly that number of people. For example, in the 10s building, each floor has ten people in it. Have the children verify that this is indeed true.

3. Using the chart, make an arc with one hand across the two numbers in one equation and up to the ten in the attic (see illustration on page 38). Associate this motion of an upward curve, which looks like a C or backwards C, with addition.

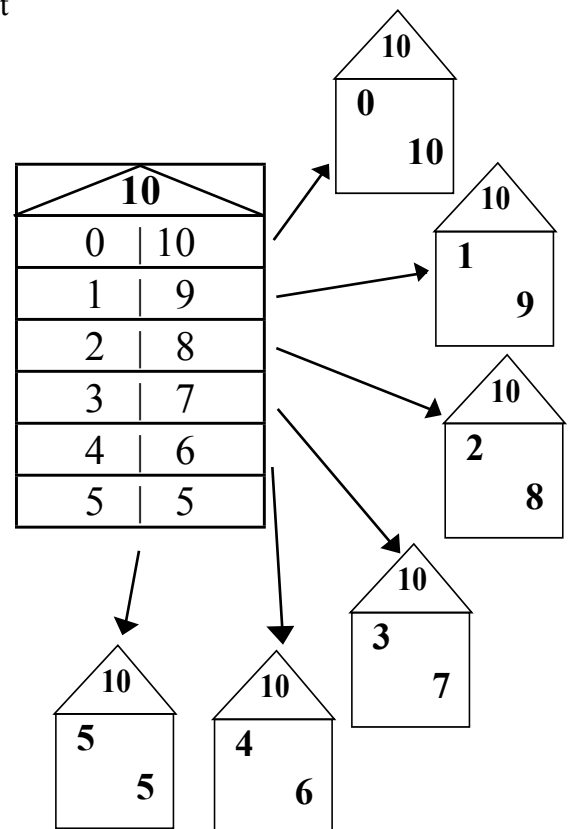



2.7a. Threes

Figure out which families can live in each house.

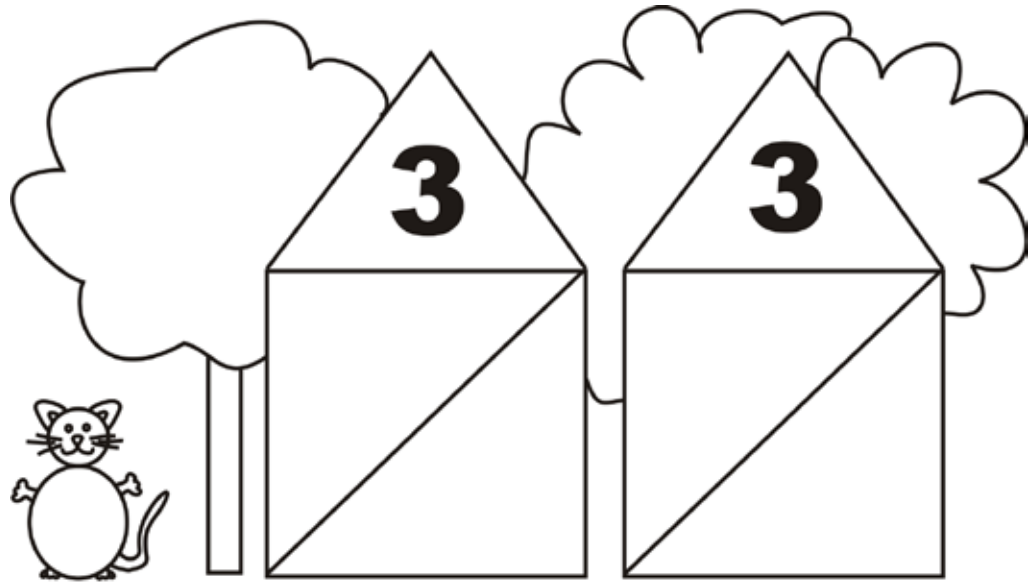

0 1 2 3

Name: \_\_\_\_\_

2.7b. Fours

Figure out which families can live in each house.

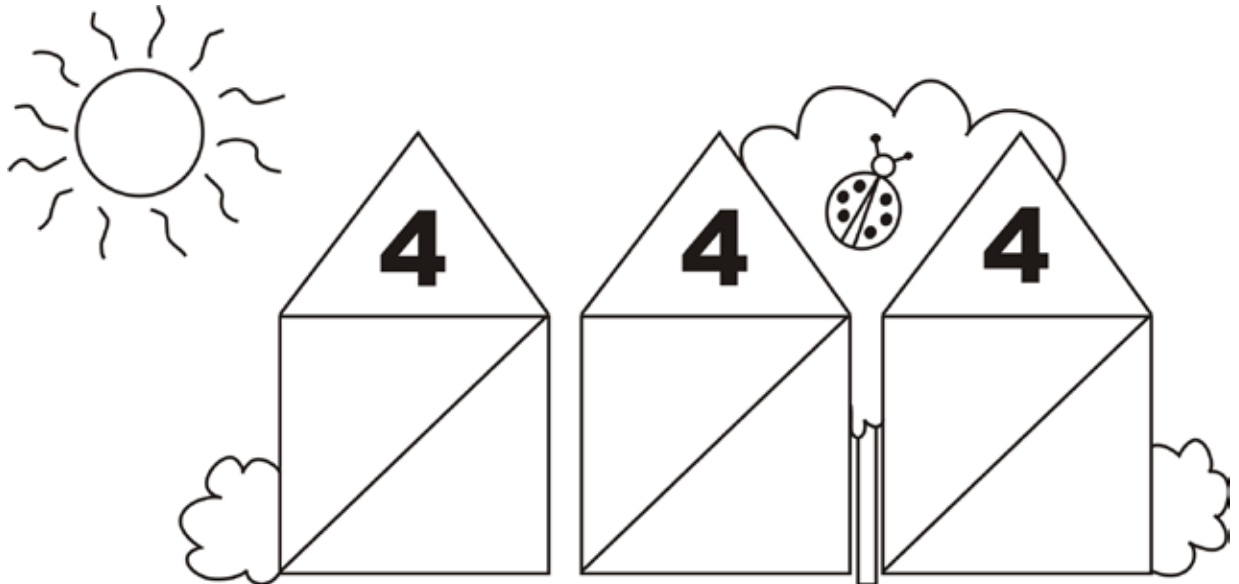

0 1 2 2 3 4

Name: \_\_\_\_\_

**2.9a. Addition and subtraction practice - threes and fours**

**Name:** \_\_\_\_\_

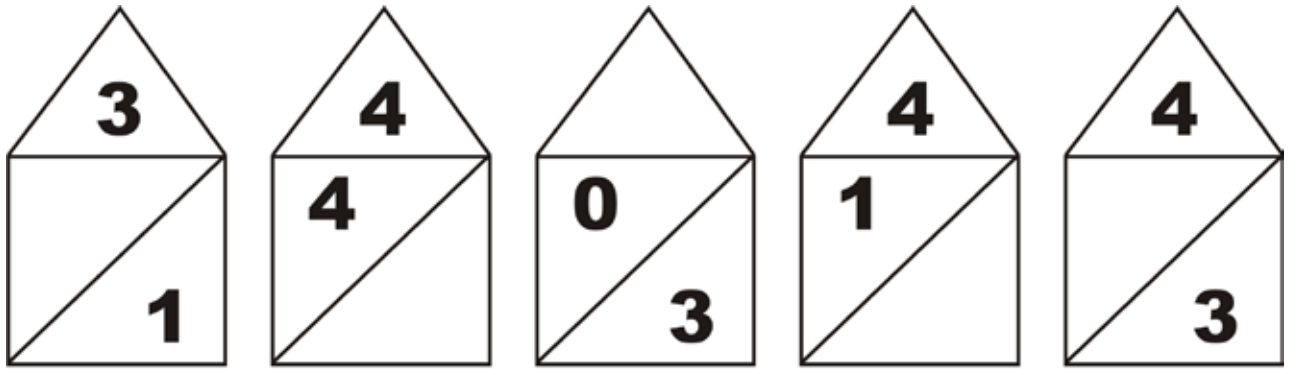

<b>3</b>	<b>4</b>	<b>1</b>	<b>2</b>	<b>3</b>	<b>0</b>	<b>4</b>	<b>1</b>
<b>- 0</b>	<b>- 4</b>	<b>+ 2</b>	<b>+ 2</b>	<b>- 1</b>	<b>+ 3</b>	<b>- 2</b>	<b>+ 3</b>

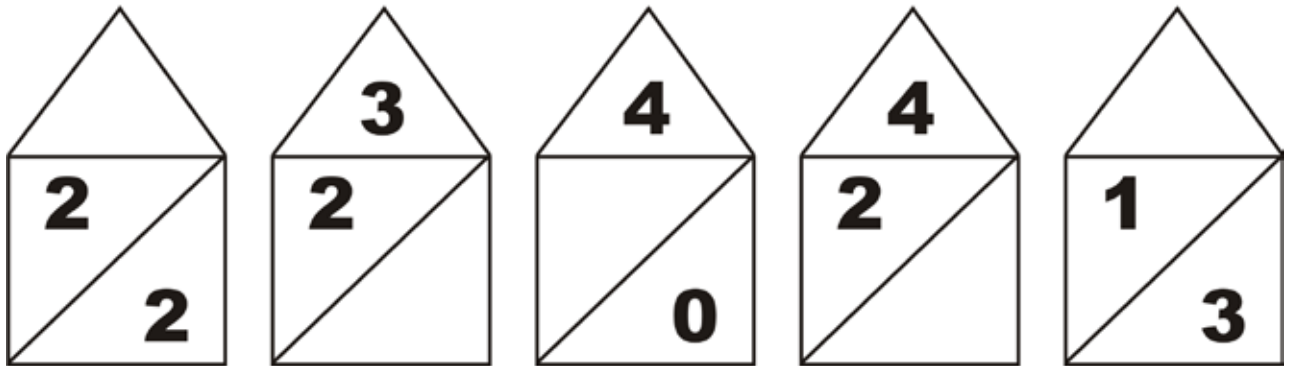

<b>4</b>	<b>3</b>	<b>3</b>	<b>4</b>	<b>4</b>	<b>3</b>	<b>3</b>	<b>2</b>
<b>- 3</b>	<b>- 2</b>	<b>+ 1</b>	<b>+ 0</b>	<b>- 1</b>	<b>+ 0</b>	<b>- 3</b>	<b>+ 1</b>

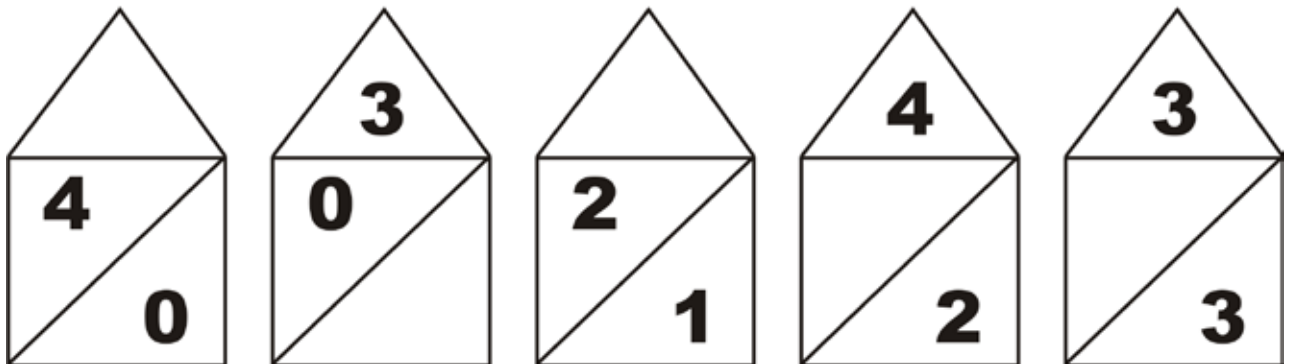

3.7. From sticks to numbers

Name: \_\_\_\_\_

Write the number shown in each office on the line underneath it.

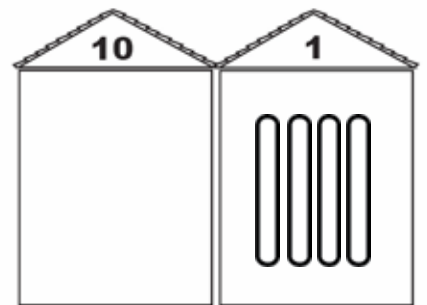
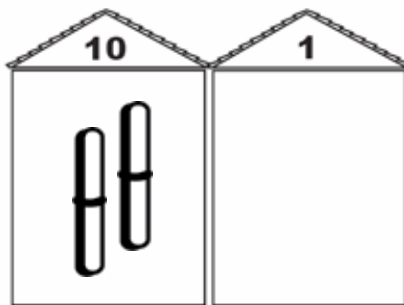
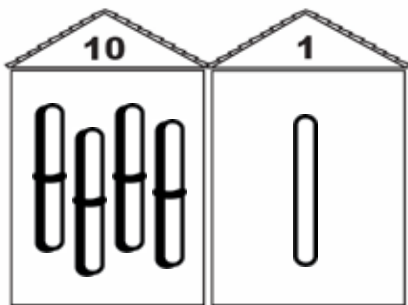
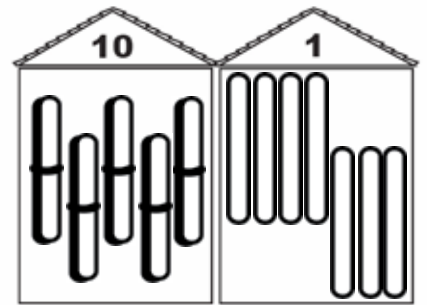
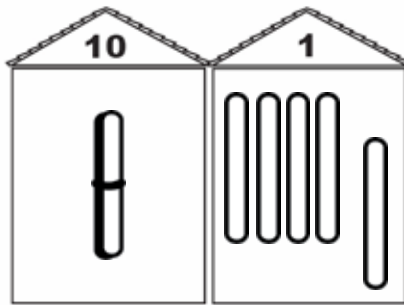
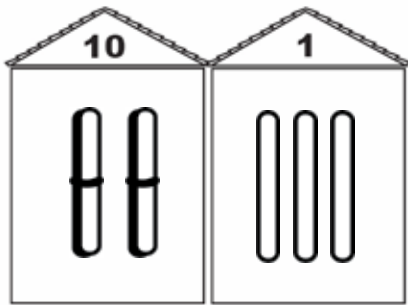
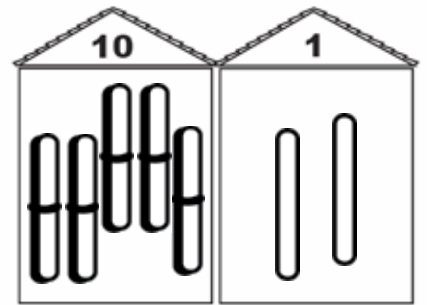
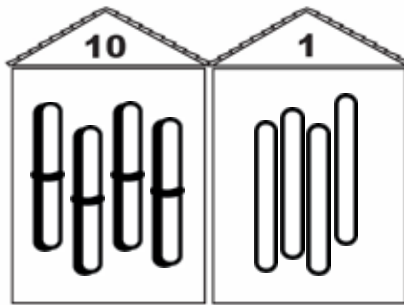
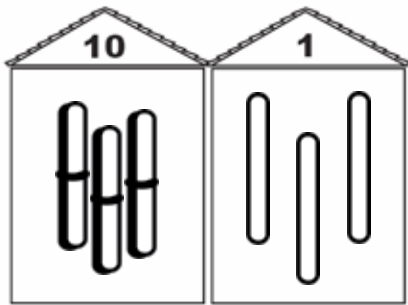
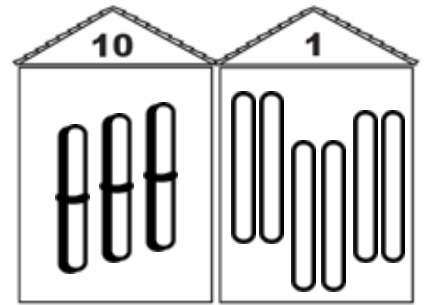
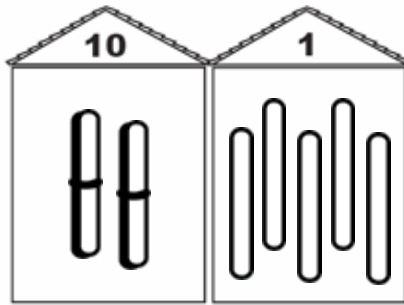
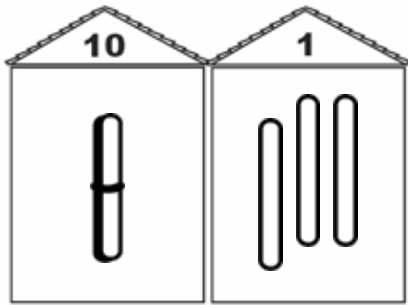

\_\_\_\_\_

\_\_\_\_\_

\_\_\_\_\_

4.3a. 1s-place subtraction cards, page 1

$$\begin{array}{r} 19 \\ - 9 \\ \hline \end{array}$$

$$\begin{array}{r} 19 \\ - 8 \\ \hline \end{array}$$

$$\begin{array}{r} 19 \\ - 7 \\ \hline \end{array}$$

$$\begin{array}{r} 19 \\ - 6 \\ \hline \end{array}$$

$$\begin{array}{r} 19 \\ - 5 \\ \hline \end{array}$$

$$\begin{array}{r} 19 \\ - 4 \\ \hline \end{array}$$

$$\begin{array}{r} 19 \\ - 3 \\ \hline \end{array}$$

$$\begin{array}{r} 19 \\ - 2 \\ \hline \end{array}$$

$$\begin{array}{r} 19 \\ - 1 \\ \hline \end{array}$$

$$\begin{array}{r} 18 \\ - 8 \\ \hline \end{array}$$

$$\begin{array}{r} 18 \\ - 7 \\ \hline \end{array}$$

$$\begin{array}{r} 18 \\ - 6 \\ \hline \end{array}$$

4.5b. "Take from ten" subtraction cards, page 2

$$\begin{array}{r} 12 \\ - 5 \\ \hline \end{array}$$

$$\begin{array}{r} 12 \\ - 4 \\ \hline \end{array}$$

$$\begin{array}{r} 12 \\ - 3 \\ \hline \end{array}$$

$$\begin{array}{r} 13 \\ - 9 \\ \hline \end{array}$$

$$\begin{array}{r} 13 \\ - 8 \\ \hline \end{array}$$

$$\begin{array}{r} 13 \\ - 7 \\ \hline \end{array}$$

$$\begin{array}{r} 13 \\ - 6 \\ \hline \end{array}$$

$$\begin{array}{r} 13 \\ - 5 \\ \hline \end{array}$$

$$\begin{array}{r} 13 \\ - 4 \\ \hline \end{array}$$

$$\begin{array}{r} 14 \\ - 9 \\ \hline \end{array}$$

$$\begin{array}{r} 14 \\ - 8 \\ \hline \end{array}$$

$$\begin{array}{r} 14 \\ - 7 \\ \hline \end{array}$$



5.3a. Taking from 1s, page 1

Name: \_\_\_\_\_

$$\begin{array}{r} 19 \\ - 3 \\ \hline \end{array}$$

$$\begin{array}{r} 15 \\ - 5 \\ \hline \end{array}$$

$$\begin{array}{r} 13 \\ - 1 \\ \hline \end{array}$$

$$\begin{array}{r} 17 \\ - 2 \\ \hline \end{array}$$

$$\begin{array}{r} 11 \\ - 0 \\ \hline \end{array}$$

$$\begin{array}{r} 13 \\ - 0 \\ \hline \end{array}$$

$$\begin{array}{r} 18 \\ - 4 \\ \hline \end{array}$$

$$\begin{array}{r} 16 \\ - 1 \\ \hline \end{array}$$

$$\begin{array}{r} 14 \\ - 3 \\ \hline \end{array}$$

$$\begin{array}{r} 12 \\ - 2 \\ \hline \end{array}$$

$$\begin{array}{r} 17 \\ - 5 \\ \hline \end{array}$$

$$\begin{array}{r} 19 \\ - 7 \\ \hline \end{array}$$

$$\begin{array}{r} 15 \\ - 1 \\ \hline \end{array}$$

$$\begin{array}{r} 15 \\ - 4 \\ \hline \end{array}$$

$$\begin{array}{r} 18 \\ - 6 \\ \hline \end{array}$$

$$\begin{array}{r} 18 \\ - 8 \\ \hline \end{array}$$

$$\begin{array}{r} 14 \\ - 1 \\ \hline \end{array}$$

$$\begin{array}{r} 17 \\ - 4 \\ \hline \end{array}$$

$$\begin{array}{r} 13 \\ - 3 \\ \hline \end{array}$$

$$\begin{array}{r} 19 \\ - 1 \\ \hline \end{array}$$

$$\begin{array}{r} 19 \\ - 5 \\ \hline \end{array}$$

$$\begin{array}{r} 15 \\ - 2 \\ \hline \end{array}$$

$$\begin{array}{r} 18 \\ - 0 \\ \hline \end{array}$$

$$\begin{array}{r} 16 \\ - 3 \\ \hline \end{array}$$

$$\begin{array}{r} 14 \\ - 2 \\ \hline \end{array}$$

8.1d. Mixed addition and subtraction in 1s place, page 4

Name: \_\_\_\_\_

$$\begin{array}{r} 17 \\ - 2 \\ \hline \end{array}$$

$$\begin{array}{r} 10 \\ + 8 \\ \hline \end{array}$$

$$\begin{array}{r} 16 \\ - 4 \\ \hline \end{array}$$

$$\begin{array}{r} 19 \\ - 1 \\ \hline \end{array}$$

$$\begin{array}{r} 12 \\ + 1 \\ \hline \end{array}$$

$$\begin{array}{r} 14 \\ + 1 \\ \hline \end{array}$$

$$\begin{array}{r} 18 \\ - 0 \\ \hline \end{array}$$

$$\begin{array}{r} 11 \\ + 4 \\ \hline \end{array}$$

$$\begin{array}{r} 14 \\ - 1 \\ \hline \end{array}$$

$$\begin{array}{r} 10 \\ + 3 \\ \hline \end{array}$$

$$\begin{array}{r} 12 \\ - 2 \\ \hline \end{array}$$

$$\begin{array}{r} 15 \\ + 4 \\ \hline \end{array}$$

$$\begin{array}{r} 19 \\ - 4 \\ \hline \end{array}$$

$$\begin{array}{r} 16 \\ + 2 \\ \hline \end{array}$$

$$\begin{array}{r} 13 \\ - 0 \\ \hline \end{array}$$

$$\begin{array}{r} 10 \\ + 2 \\ \hline \end{array}$$

$$\begin{array}{r} 16 \\ - 2 \\ \hline \end{array}$$

$$\begin{array}{r} 12 \\ + 5 \\ \hline \end{array}$$

$$\begin{array}{r} 17 \\ - 1 \\ \hline \end{array}$$

$$\begin{array}{r} 11 \\ + 7 \\ \hline \end{array}$$

$$\begin{array}{r} 18 \\ - 6 \\ \hline \end{array}$$

$$\begin{array}{r} 18 \\ + 1 \\ \hline \end{array}$$

$$\begin{array}{r} 10 \\ + 6 \\ \hline \end{array}$$

$$\begin{array}{r} 15 \\ - 5 \\ \hline \end{array}$$

$$\begin{array}{r} 19 \\ - 0 \\ \hline \end{array}$$

Name: \_\_\_\_\_

$$\begin{array}{r} 44 \\ - 22 \\ \hline \end{array}$$

$$\begin{array}{r} 53 \\ + 21 \\ \hline \end{array}$$

$$\begin{array}{r} 45 \\ - 24 \\ \hline \end{array}$$

$$\begin{array}{r} 64 \\ + 13 \\ \hline \end{array}$$

$$\begin{array}{r} 54 \\ - 32 \\ \hline \end{array}$$

$$\begin{array}{r} 13 \\ + 25 \\ \hline \end{array}$$

$$\begin{array}{r} 47 \\ - 26 \\ \hline \end{array}$$

$$\begin{array}{r} 55 \\ + 24 \\ \hline \end{array}$$

$$\begin{array}{r} 54 \\ - 32 \\ \hline \end{array}$$

$$\begin{array}{r} 13 \\ + 33 \\ \hline \end{array}$$

$$\begin{array}{r} 37 \\ - 26 \\ \hline \end{array}$$

$$\begin{array}{r} 16 \\ + 42 \\ \hline \end{array}$$

$$\begin{array}{r} 59 \\ - 36 \\ \hline \end{array}$$

$$\begin{array}{r} 15 \\ + 83 \\ \hline \end{array}$$

$$\begin{array}{r} 88 \\ - 33 \\ \hline \end{array}$$

$$\begin{array}{r} 12 \\ + 14 \\ \hline \end{array}$$

$$\begin{array}{r} 46 \\ - 24 \\ \hline \end{array}$$

$$\begin{array}{r} 13 \\ + 46 \\ \hline \end{array}$$

$$\begin{array}{r} 66 \\ - 33 \\ \hline \end{array}$$

$$\begin{array}{r} 62 \\ + 37 \\ \hline \end{array}$$

$$\begin{array}{r} 87 \\ - 35 \\ \hline \end{array}$$

$$\begin{array}{r} 84 \\ + 15 \\ \hline \end{array}$$

$$\begin{array}{r} 77 \\ - 44 \\ \hline \end{array}$$

$$\begin{array}{r} 23 \\ + 46 \\ \hline \end{array}$$

$$\begin{array}{r} 75 \\ - 53 \\ \hline \end{array}$$

9.8a. Multi-digit take from ten

Name: \_\_\_\_\_

$$\begin{array}{r} 364 \\ - 177 \\ \hline \end{array}$$

$$\begin{array}{r} 623 \\ - 178 \\ \hline \end{array}$$

$$\begin{array}{r} 748 \\ - 169 \\ \hline \end{array}$$

$$\begin{array}{r} 533 \\ - 166 \\ \hline \end{array}$$

$$\begin{array}{r} 737 \\ - 168 \\ \hline \end{array}$$

$$\begin{array}{r} 846 \\ - 179 \\ \hline \end{array}$$

$$\begin{array}{r} 542 \\ - 177 \\ \hline \end{array}$$

$$\begin{array}{r} 466 \\ - 187 \\ \hline \end{array}$$

$$\begin{array}{r} 932 \\ - 167 \\ \hline \end{array}$$

$$\begin{array}{r} 747 \\ - 178 \\ \hline \end{array}$$

9.8b. Multi-digit take from ten

Name: \_\_\_\_\_

$$\begin{array}{r} 844 \\ - 359 \\ \hline \end{array}$$

$$\begin{array}{r} 744 \\ - 368 \\ \hline \end{array}$$

$$\begin{array}{r} 831 \\ - 279 \\ \hline \end{array}$$

$$\begin{array}{r} 322 \\ - 276 \\ \hline \end{array}$$

$$\begin{array}{r} 535 \\ - 269 \\ \hline \end{array}$$

$$\begin{array}{r} 844 \\ - 367 \\ \hline \end{array}$$

$$\begin{array}{r} 626 \\ - 248 \\ \hline \end{array}$$

$$\begin{array}{r} 534 \\ - 267 \\ \hline \end{array}$$

$$\begin{array}{r} 643 \\ - 288 \\ \hline \end{array}$$

$$\begin{array}{r} 745 \\ - 278 \\ \hline \end{array}$$

# APPENDIX B

## MONITORING & TRACKING FORMS

Tracking forms for Chapter 2 .....	207
Tracking forms for Chapters 3 - 4 .....	210
Tracking forms for Chapters 5 - 7 .....	212
Tracking forms for Chapters 8 - 9 .....	214

# APPENDIX C

## ANSWER KEYS