

KKNL-018

**DEALERS MUST TRANSLATE THEIR OWN LANGUAGE OF
MANUAL INSTRUCTIONS BELOW FOR YOUR MARKET**

**PLEASE READ THE INSTRUCTIONS
CAREFULLY BEFORE USE**

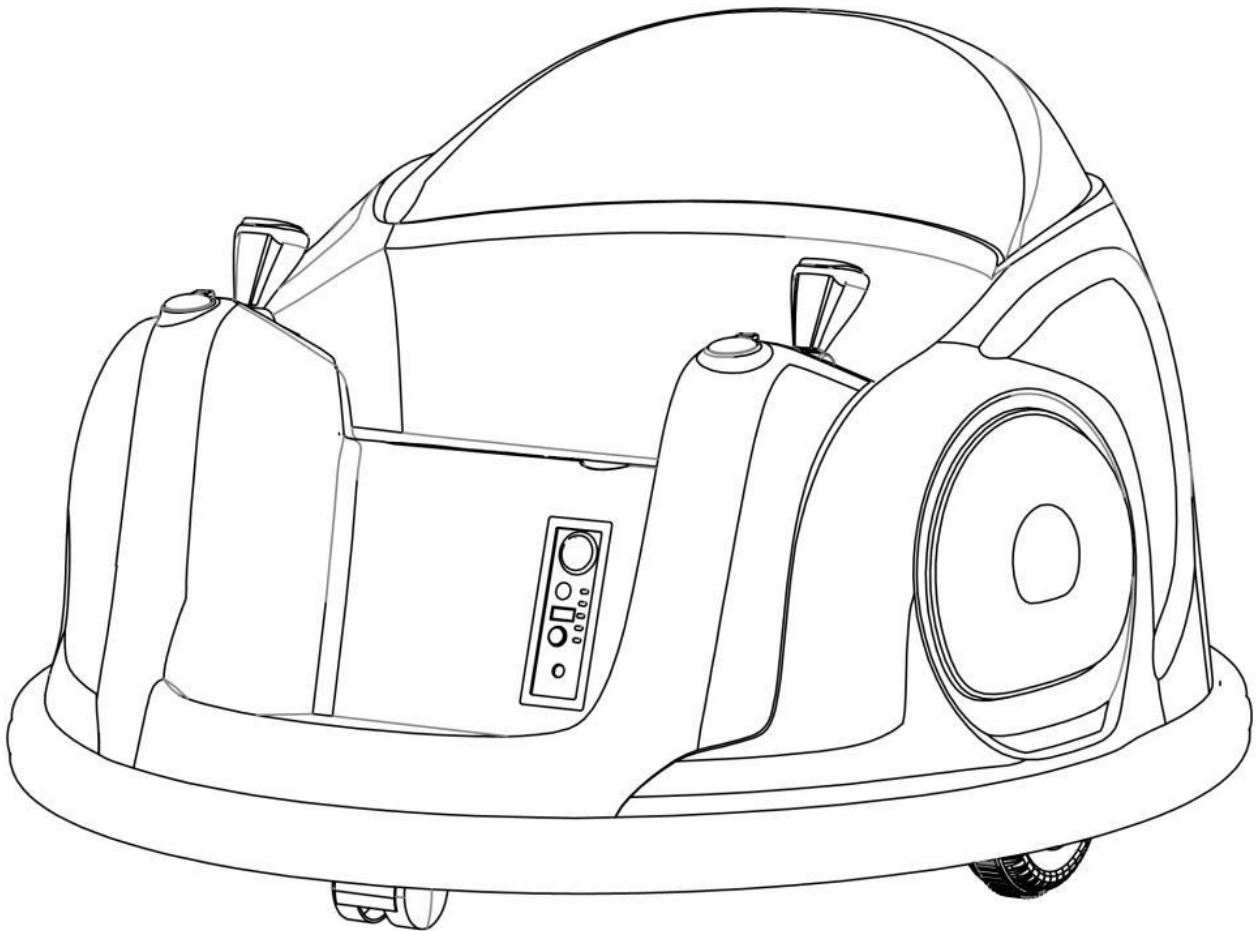

Styles and colors may vary

**Keep the package away from children and dispose of properly before
use**

1. Specification:

Motor	380*14000 *2	
Battery	6V4AH*1	
Charger	6V500MA / 6V1000MA	
Speed	1~1.5 km/hr	

Suitable age : 37-96 months

Load Capacity: Under 25KGS

Size of car: 66.5*66.5*44CM

Power way: Charging type

Charge time : 8-12 hours

2.Packing list:

Number	Name	Quantity
1	Remote Control	1
2	Charger	1
3	Manual	1

Assembly tools required:



Cross screwdriver
(not included)

WARNING!

FOR THE SAFETY OF YOUR CHILDREN , PLEASE READ ALL WARNINGS AND ASSEMBLY/USE INSTRUCTIONS.KEEP THIS GUIDE FOR FUTURE REFERENCE.

- ADULT ASSEMBLY REQUIRED. The product contains small parts, which are for adult assembly only. Keep children away when assembling.
- Always remove protective material and poly bags and dispose before assembly.

2. Operation Instruction:

A. Backrest installation

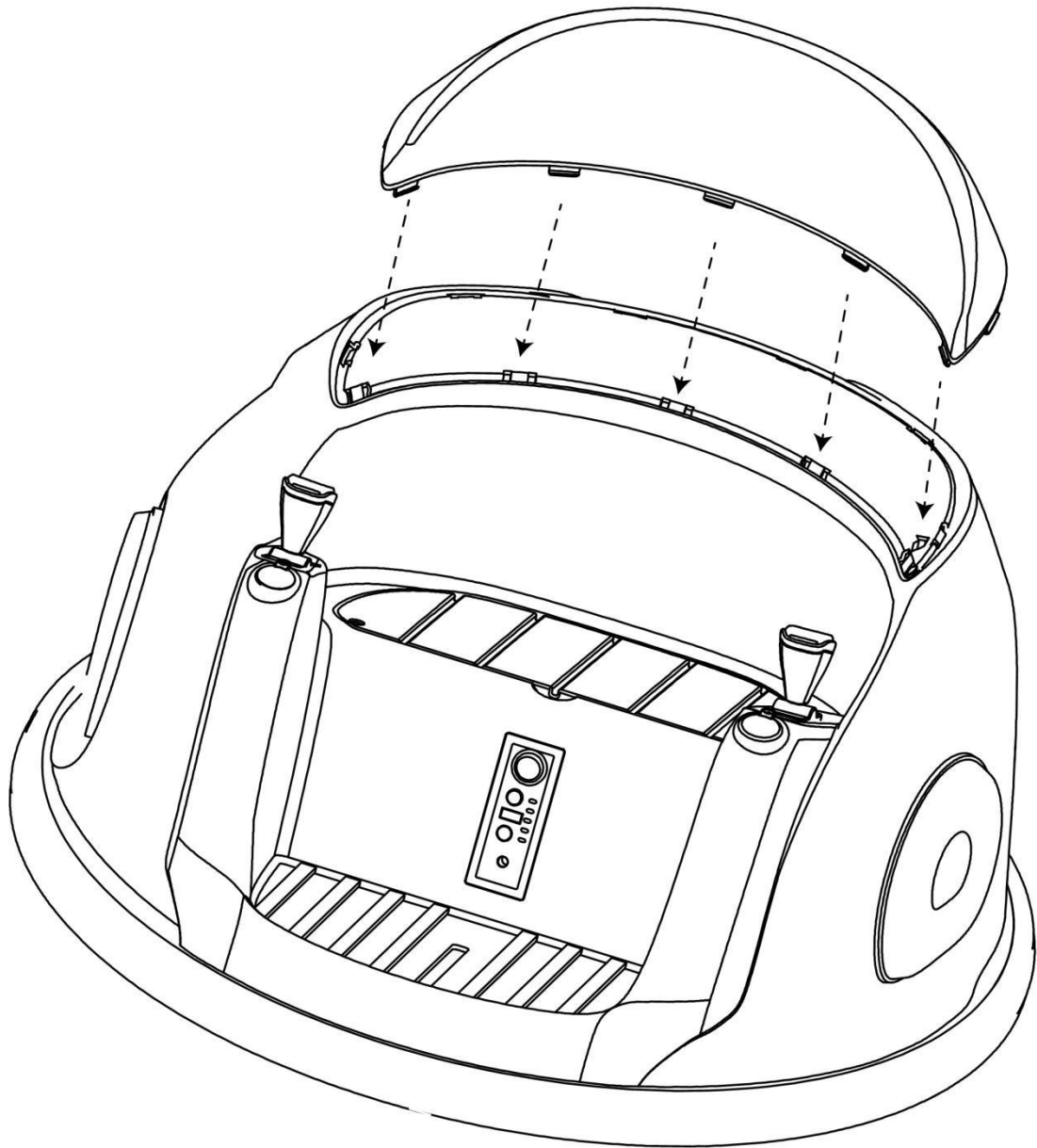

Clip the backrest into the body slot;

B. Power Connecting & Install seat (Optional)

Configuration 1

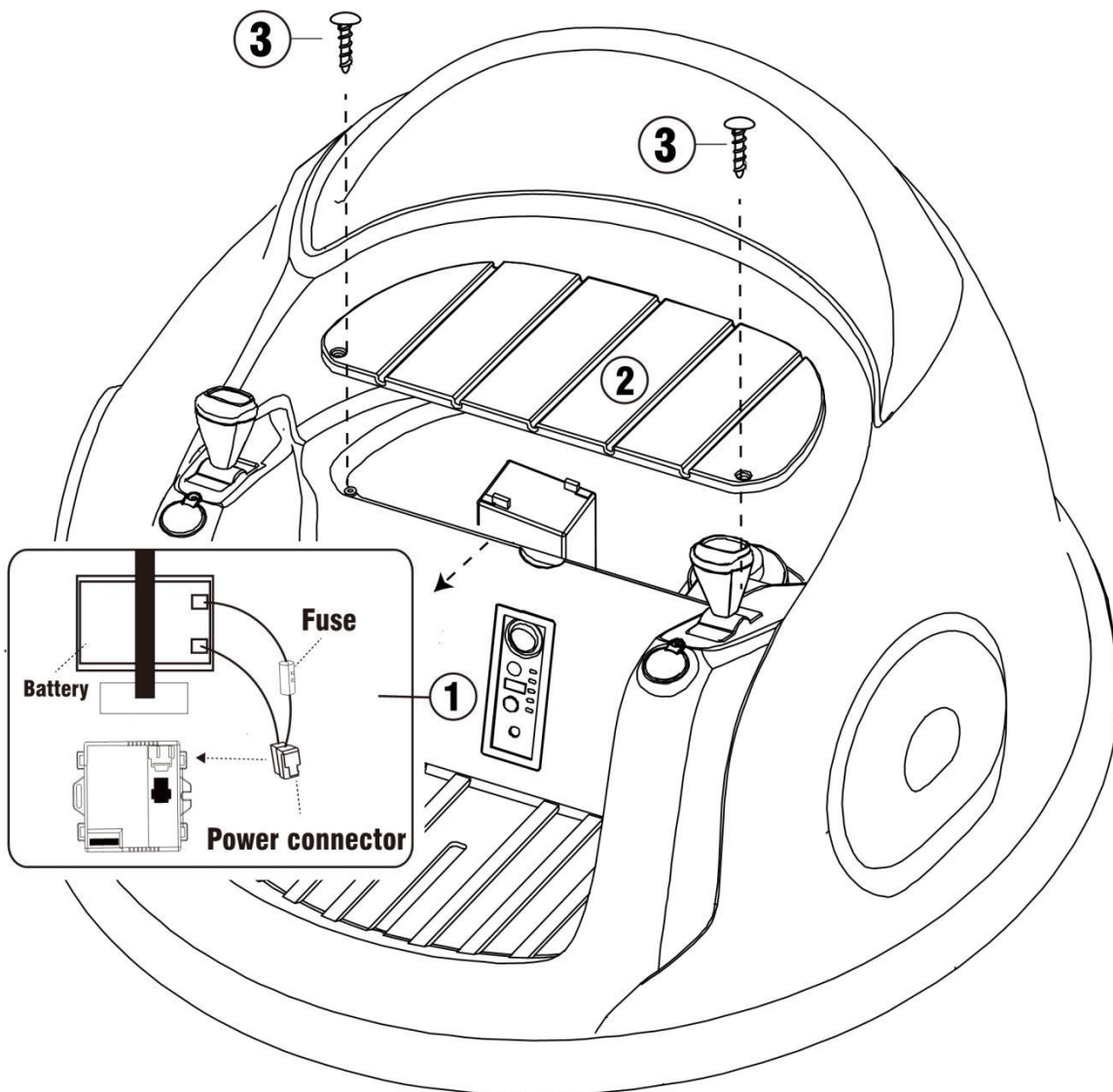

1. Find the main power line and insert the plug-in of the power line into the corresponding socket of the receiver;
2. Cover the seat on the battery
3. Fix the seat with screw by cross screwdriver

Configuration 2

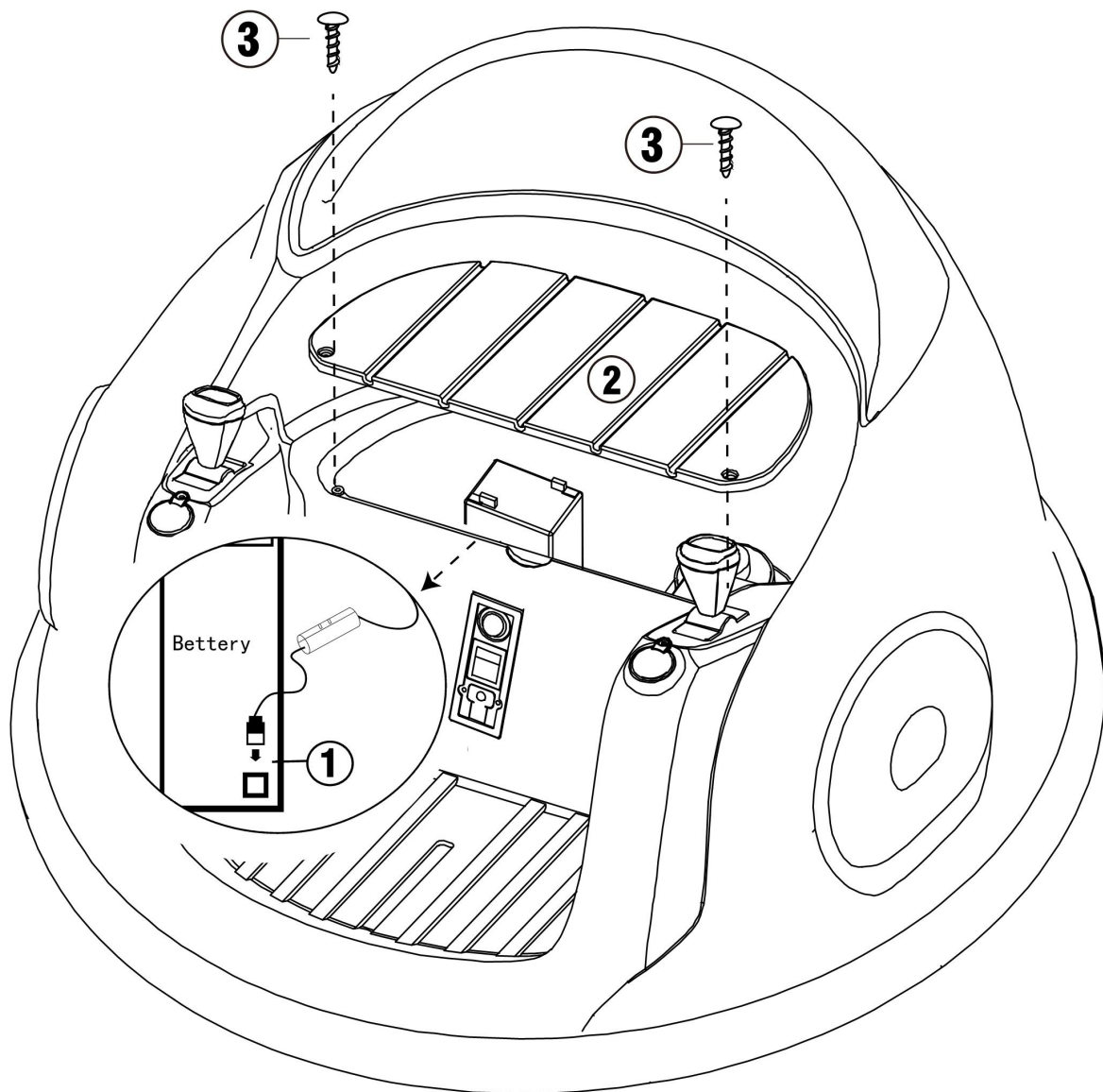

1. Access the battery under the seat, connect the battery terminals (red to red, Black to black)
2. Cover the seat on the battery
3. Fix the seat with screw by cross screwdriver

C. Function introduction (Optional)

Configuration 1

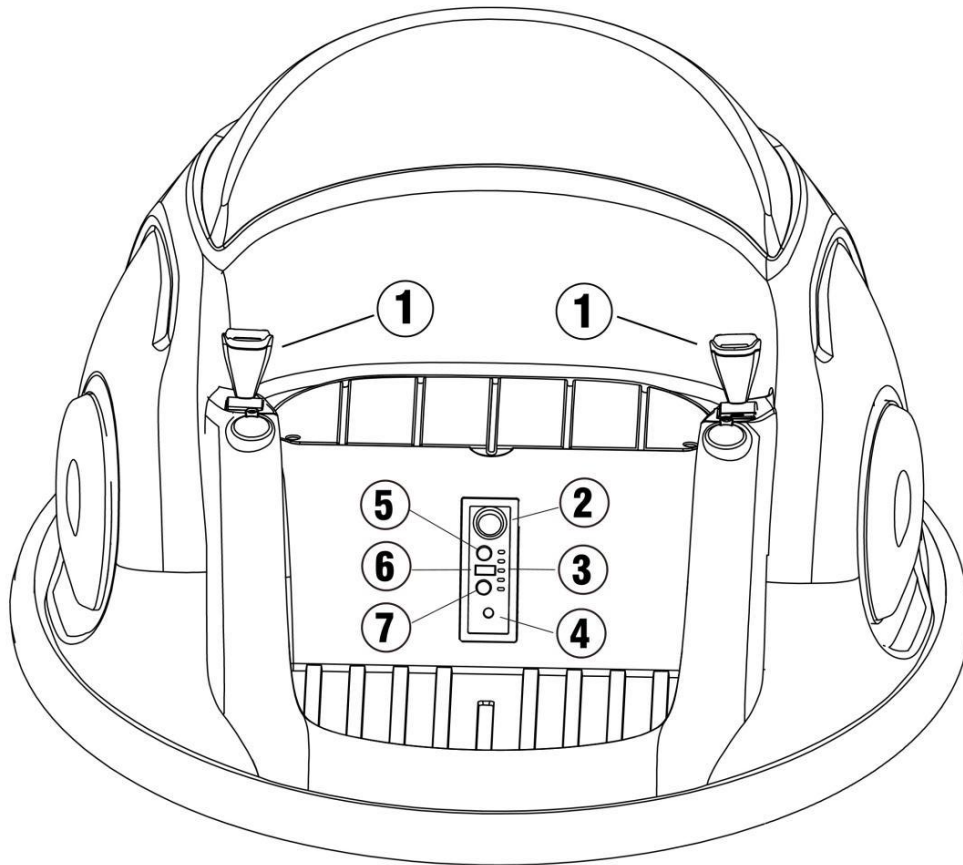

1. Forward-backward button: control the car forward or backward ,middle is stop
2. Power button: Turn the vehicle on and off
3. Power display: Clearly see the battery power, in order to charge.
4. Socket: charge.
5. Bluetooth function / music function: Click to switch mode;
6. USB;
7. Next song: Switch songs.

Configuration 2

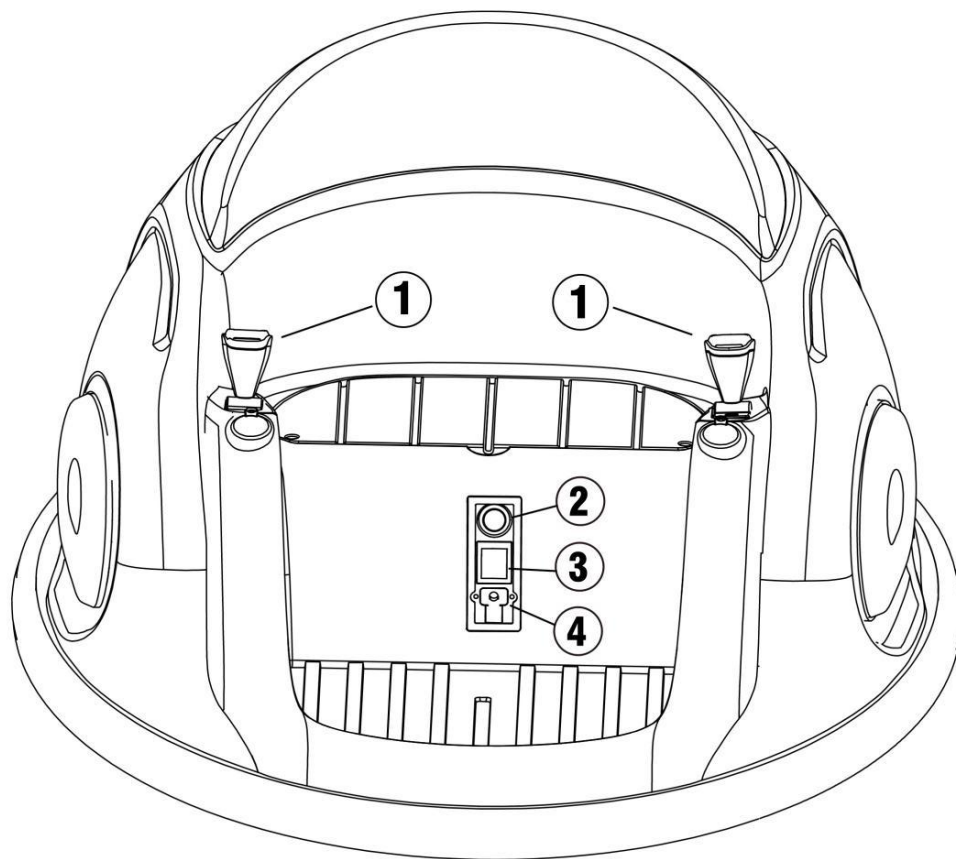

1. Forward-backward button : control the car forward or backward ,middle is stop
2. Power button: Turn the vehicle on and off
3. Light button: Turn on /off the light
4. Socket : Charge

D. Dinner plate installation

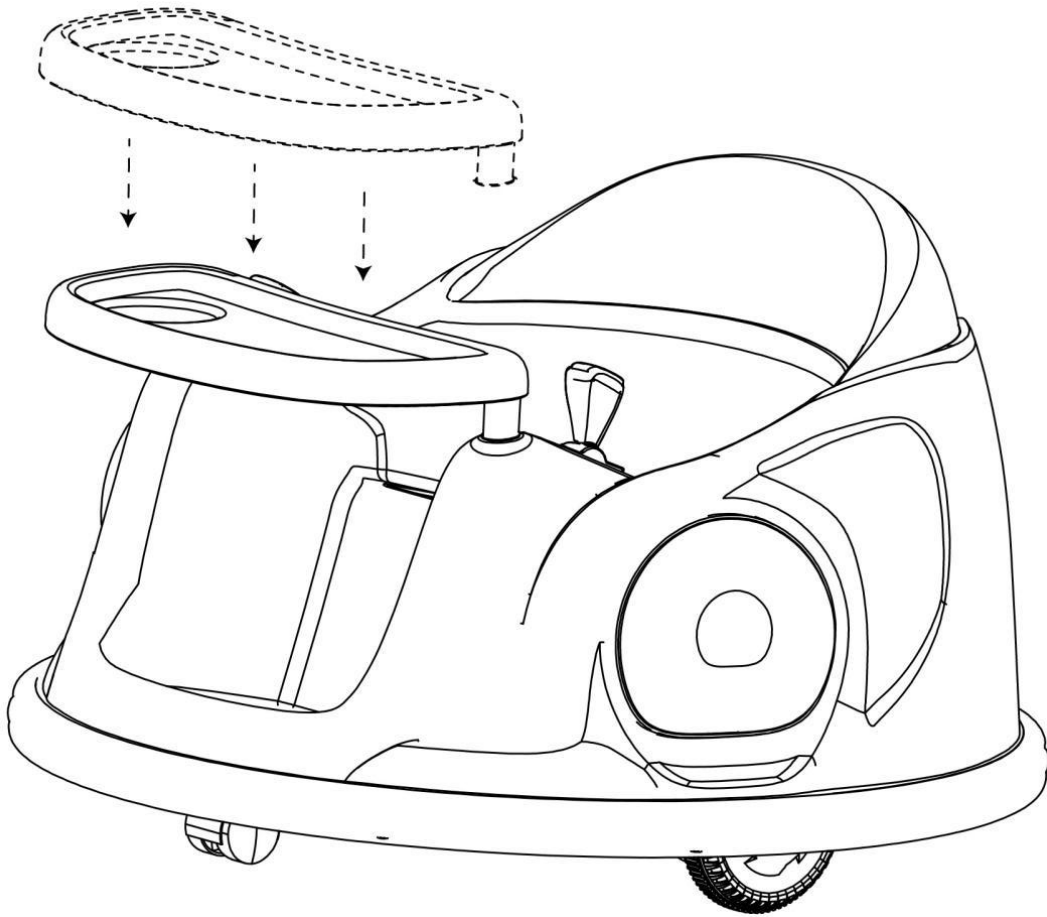

1. Clip the dining plate into the car body slot;

E. Use The Remote Control

**NOTE: This product does not include the AAA(1.5v) batteries
Only allow adult to use remote control, can not let the children touch**

Subject to the material object

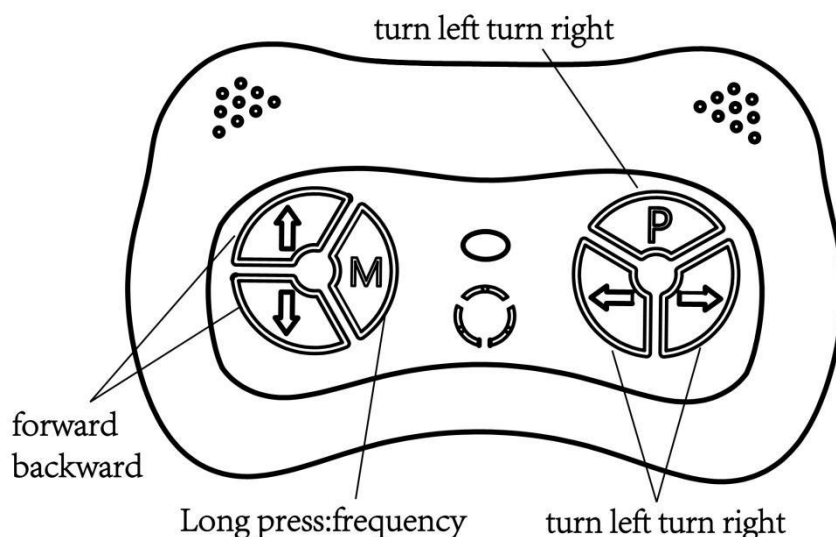

Operation manual : For the first time use (Or Replace the battery)Need to frequency pair

- Take out the remote control, install the battery
- Long press on the button “M” for 2-4 seconds, Indicator light will flash
- Turn on the power of the car, Indicator light flashes to solid light, then frequency pair is completed
- If the frequency bind failed (Indicator light flashes) , remove the battery and repeat steps 1~3
- remote control without operation after 10 seconds, Indicator light will turn off into power saving mode
- Button Description: \triangle forward ∇ backward \triangleleft turn left \triangleright turn right

P: emergency brake, press it and the running function will fail, press again, it release

4. Safety

 **WARNING!**

PREVENT INJURIES AND DEATHS:

- **NEVER LEAVE CHILD UNATTENDED. DIRECT ADULT SUPERVISION IS REQUIRED.** Always keep child in view when child is in vehicle.
- This toy should be used with caution since skill is required to avoid falls or collisions causing injury to the user or third parties.
- Protective equipment should be worn.
- Never use in roadways, near cars, on or near steep inclines or steps, swimming pools or other bodies of water.
- Always wear shoes.
- Always sit on the seat.
- Not to be used in traffic.
- This toy is unsuitable for children under 37 months due to its maximum speed; Maximum user weight is 25 kgs.
- This toy has no brake.

Rules for Safe Riding

- Keep Children within safe riding areas:

Never use in roadway, near motor vehicles, on lawn space , on or near steep inclines or steps swimming pools or other bodies of water;

Use the toy only on flat surfaces. Such as inside your house, garden or playground

- Never use in the dark . A child could encounter unexpected obstacles and have an accident. Operate the vehicles only in the daytime or well-lit area.
- It is prohibited to change the circuit or add other electric parts.
- Inspect wires and connections of the vehicle periodically
- Do not let any child touch the wheels or be near them when the car is moving.

NEVER pick up the battery by the wires or charger. Damage can occur to the battery and may cause a fire. Pick up the battery by the case ONLY.

- Charge the battery in a dry area ONLY.

- Battery posts, terminals and related accessories contain lead and lead compounds, chemicals known to the State of California to cause cancer and reproductive harm.

Wash hands after handling.

- Do not open the battery. Battery contains lead acid and other materials that are toxic and corrosive.
- Do not open the charger. Exposed wiring and circuitry inside case electric shock.. Only adults may handle or charge the batter. NEVER allow child to handle or charge the battery. Battery is heavy and contains lead acid (electrolyte).
- Do not drop the battery. Permanent damage to the battery could occur or cause serious injury.
- Before charging the battery, check for wear or damage to the battery, charger, its supply cord and the connectors. DO NOT charge the battery if any damage to parts has occurred.

- Do not allow the battery to drain completely. **Recharge the battery after each use or once a month if not used regularly.**
- Do not charge battery upside down.
- Always secure the battery with bracket, Battery can fall out and injure a child if vehicle tips over.
- The POWER SWITCH must be turned in OFF position when charging.
- Before the first use, you should charge the battery for 4-6 hours. Do not recharge the battery for more than 10 hours to avoid overheating the charger.
- When the vehicle begins to run slowly, recharge the battery.
- After each use or once a month minimum recharge times as 8 to 12 hours, less than 20 hours at most.

5. Charging

ONLY AN ADULT CAN CHARGE AND RECHARGE THE BATTERY!

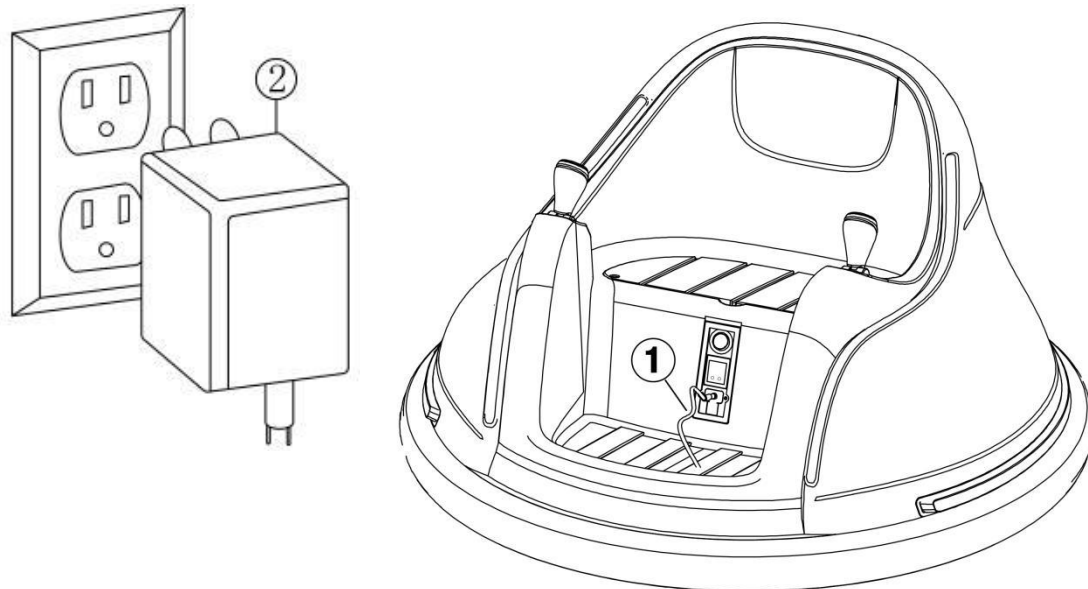

Put the charger plug into the socket as picture

Please turn off the power before Charge

6. Battery Replacement

To avoid losing power , follow these guidelines:

- Do not overload the vehicle.
- Do not tow anything behind the vehicle.
- Do not drive up steep slopes.
- Do not drive into fixed objects, which may cause the wheels to spin, causing the motor to overheat.
- Do not drive in very hot weather, components may overheat.
- Do not allow water or other liquid to come in contact with the battery or other electric components.
- Do not tamper with the electric system. Doing so may create a short , causing the fuse to trip.

7.Troubleshooting Guide

Problem	Possible Cause	Solution
Vehicle dose not run	Battery low on power	Recharge battery
	Fuse has broken	Replace,see<Fuse>
	Battery connector or wires are loose	Check that battery connectors are firmly plugged into each other. If wires are loose around the motor contact your distributor please
	Battery is dead	Replace battery ,contact your distributor please
	Electrical system is damaged	Contact your distributor please
	Motor is damaged	Contact your distributor please
Vehicle dose not run very long	Batter is under charged	Check that the battery connectors are firmly plugged into each other when recharging
	Battery is old	Replace battery, contact your distributor please.
Vehicle runs sluggishly	Battery low on power	Recharge battery, contact your distributor please.
	Battery is old	Recharge battery, contact your distributor please.
	Vehicle is overload	Reduce weight on vehicle. Maximum user weight is 25 kgs.
	Vehicle is being used in harsh conditions	Avoid using vehicle in harsh conditions, see<safety>
Vehicle needs a push to go forward	Poor contact of wires or connectors	Check that the battery connectors are firmly plugged into each other. If wires are loose around the motor, contact your distributor please.
	“Dead Spot” on motor	A dead spot means the electric power is not being delivered to the terminal connection and the vehicle needs repair. Contact your distributor please.
Loud grinding or clicking noises coming from motor or gear box	Motor or gears are damaged	Contact your distributor please.
Battery with not recharge	Battery connector adapter connector is loose	Check that the battery connectors are firmly plugged into each other.
	Charger not plugged in	Check that the battery charge is plugged into a working wall outlet.
	Charger is not working	Contact your distributor please.
Charger feels warm when recharging	This is normal and not a cause for concem	

Completely read through this manual and the troubleshooting guide table before calling. If you still need help resolving the problem **Contact your distributor please.**

8.Maintaining

- It is parents' responsibility to check main parts of the toy before using, Must regularly examine for potential hazard, such as the battery, charge, cable or cord, plug, screws are fastening enclosure of other parts and that in the event of such damage, the toy must not be until that damage had been properly removed.
- Make sure the plastic parts of the vehicle are not cracked or broken.
- Occasionally use a lightweight oil to lubricate moving parts such as wheels.
- Park the vehicle indoors or cover it with a tarp to protect it from wet weather.
- Keep the vehicle away from sources of heat, such as stoves and heaters. Plastic parts may melt.
- Recharge the battery after each use. Only an adult can handle the battery. Recharge the battery at least once a month when the vehicle Raider is not being used.
- Do not wash the vehicle with a hose. Do not wash the vehicle with soap and water. Do not drive the vehicle in rainy or snowy weather. Water will damage the motor, electric system and battery.
- Clean the vehicle with a soft, dry cloth. To restore shine to plastic parts, use a non-wax furniture polish. Do not use car wax. Do not use abrasive cleaners.
- Do not drive the vehicle in loose dirt, sand or fine gravel which could damage moving parts, motors or the electric system.
- When not using, all the electrical source should be turn off. Turn off the power switch and disconnect the battery connection.

FCC Statement

Caution:

This device complies with Part 15 of the FCC Rules. Operation is subject to the following two conditions: (1) this device may not cause harmful interference. (2) this device must accept any interference received, including interference that may cause undesired operation.

Changes or modifications not expressly approved by the party responsible for compliance could void the user's authority to operate the equipment.

This equipment has been tested and found to comply with the limits for a Class B digital device, pursuant to part 15 of the FCC Rules. These limits are designed to provide reasonable protection against harmful interference in a residential installation. This equipment generates uses and can radiate radio frequency energy and, if not installed and used in accordance with the instructions, may cause harmful interference to radio communications. However, there is no guarantee that interference will not occur in a particular installation. If this equipment does cause harmful interference to radio or television reception, which can be determined by turning the equipment off and on, the user is encouraged to try to correct the interference by one or more of the following measures:

- Reorient or relocate the receiving antenna.
- Increase the separation between the equipment and receiver.
- Connect the equipment into an outlet on a circuit different from that to which the receiver is connected.
- Consult the dealer or an experienced radio/TV technician for help.