

TYPICAL INSETS

FOR the actual cutting and placing of a godet or inset follow the Vogue Pattern which you have selected. These sketches show the method only. Very circular godets or flounces require the same treatment as circular skirts. The material will sag more or less, and the hem should be left unfinished until the skirt or frock has been allowed to hang overnight. If the bias sides of a godet are joined to a straight slash, baste the seam but let it hang overnight before stitching it. If the bias puckers, remove bastings and let bias edge drop until it hangs smoothly. Rebaste and stitch. Handle a godet very carefully at the point, sewing from the hem-line toward the point, with the slash side toward you, and back toward the hem on the other side. Trim the point of the godet before you open the seam. If a section is to be set into a square opening, be sure to clip the corners of the opening—as in 280A, below. For a pleated inset, look at page 39, sketches 235 and 236.

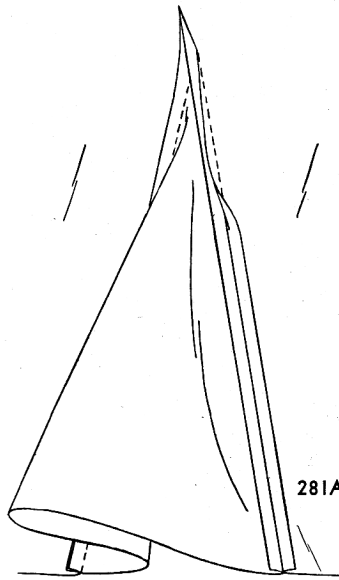

281A

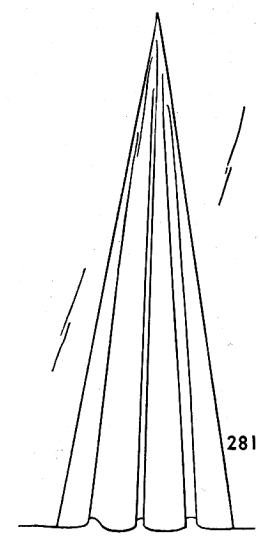

281B

Circular godet set into a slash. Note tapering seam of slash. Trim point of godet

Right side of godet, with seam opened and pressed. When you turn hem see 116, 117 and 118, page 23

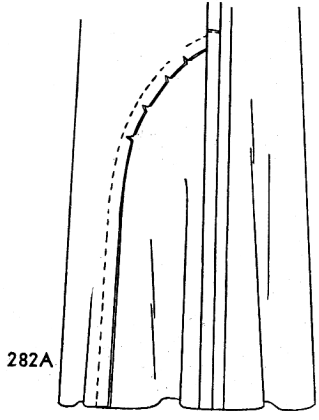

282A

Flaring section set in at one side of seam. Note the notches on the curved edge

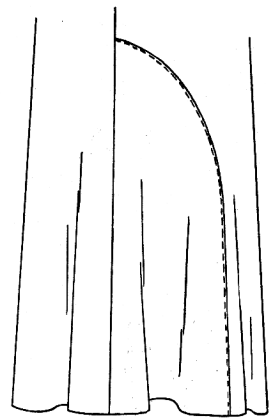

282B

Right side view of flaring section set in at one side of seam, and edge-stitched

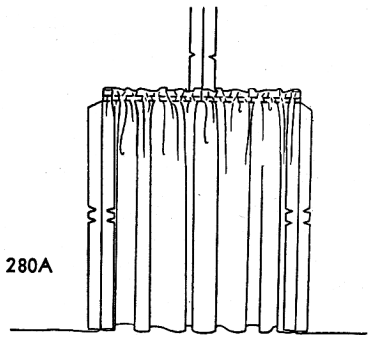

280A

Gathered inset below a seam. Space gathers as in 279 on facing page. Clip corners

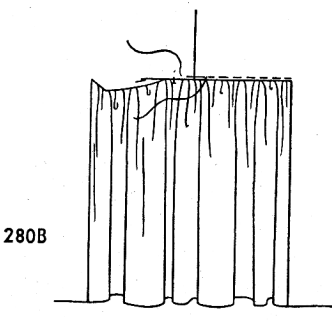

280B

Right side of gathered inset below seam—partly finished to show how corner is clipped so that seam will be flat

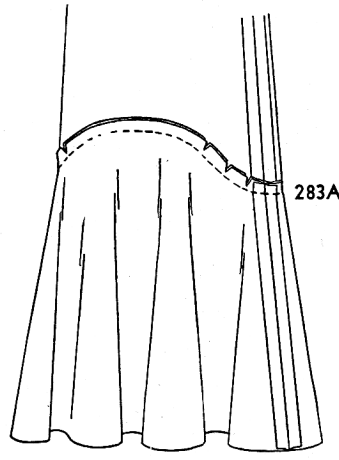

283A

Circular flounce, joined to skirt. Notice that seams of the two sections are in line. Clip seam at inner curve

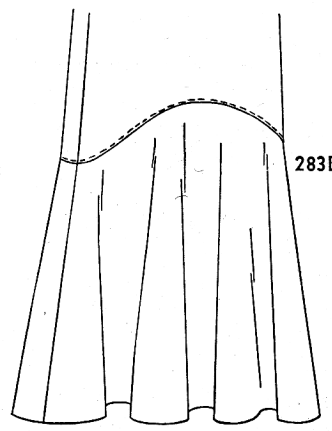

283B

Outside view of circular flounce. Before you turn the hem, see directions for a circular skirt on page 23