



OLYMPIC PLATE TREE W/ BAR HOLDERS

Model 843OPT-B

+ Owner's Manual

V2.0—06.2012

www.tko.com

THIS PAGE INTENTIONALLY LEFT BLANK

+ Safety

Read this owner's manual carefully before assembling or using TKO equipment.

WARNING: Serious injury could occur if these safety precautions are not observed

Safety Precautions

- Before beginning any exercise program, consult your personal physician. Evaluate your present fitness level and determine the exercise program that is most appropriate for your particular age and condition.
- If you experience any pain or tightness in your chest, irregular heartbeats, shortness of breath, faintness or other unusual discomfort while exercising, stop and consult your physician before continuing.
- Make sure that the equipment(s) are set up and operated on a solid level surface. DO NOT install or use the equipment on an uneven surface.
- Exercise equipment has moving parts. In the interest of safety, keep others, especially children, at a safe distance while exercising.
- Make sure there are enough room for access and operate the equipment(s) safely.
- Inspect and maintain the equipment(s) regularly.
- Replace the worn or damaged parts / components immediately to ensure safety.
- Use a spotter.
- Back support cushion may drop when knob is pulled. Hold the back support cushion when adjusting it.
- Make sure the pull pin is fully engaged before use.
- Lower the back support cushion to the lowest position when not in use.
- Warm up 5 to 10 minutes before each workout and cool down 5 to 10 minutes afterward. Never hold your breath while exercising.
- Remove all jewelry, including rings, chains and pins before commencing exercise.
- Always wear suitable clothing and footwear during exercise. Do NOT wear loose fitting clothing that could become entangled with the moving parts of your exercise machine.
- Rest adequately between workouts. Muscles tone and develop during these rest periods.
- Most exercise equipment is not recommended for small children. Children should not use the machine unless they are under adult supervision.

If you have any question or need assistance please contact us at,

Customer Service: 866-856-3488 or 713-895-9270

e mail: customerservice@tko.com

Hours: Monday-Friday 8:30am to 4:30pm CT

© Copyright 2011, TKO Sports Group USA Limited. All rights reserved.

TKO Sports Group USA Limited. 4660 Pine Timbers, Suite 198, Houston, TX 77041

Phone + 713-895-9270 Fax + 713-934-8495

www.tko.com

+ Product Diagram

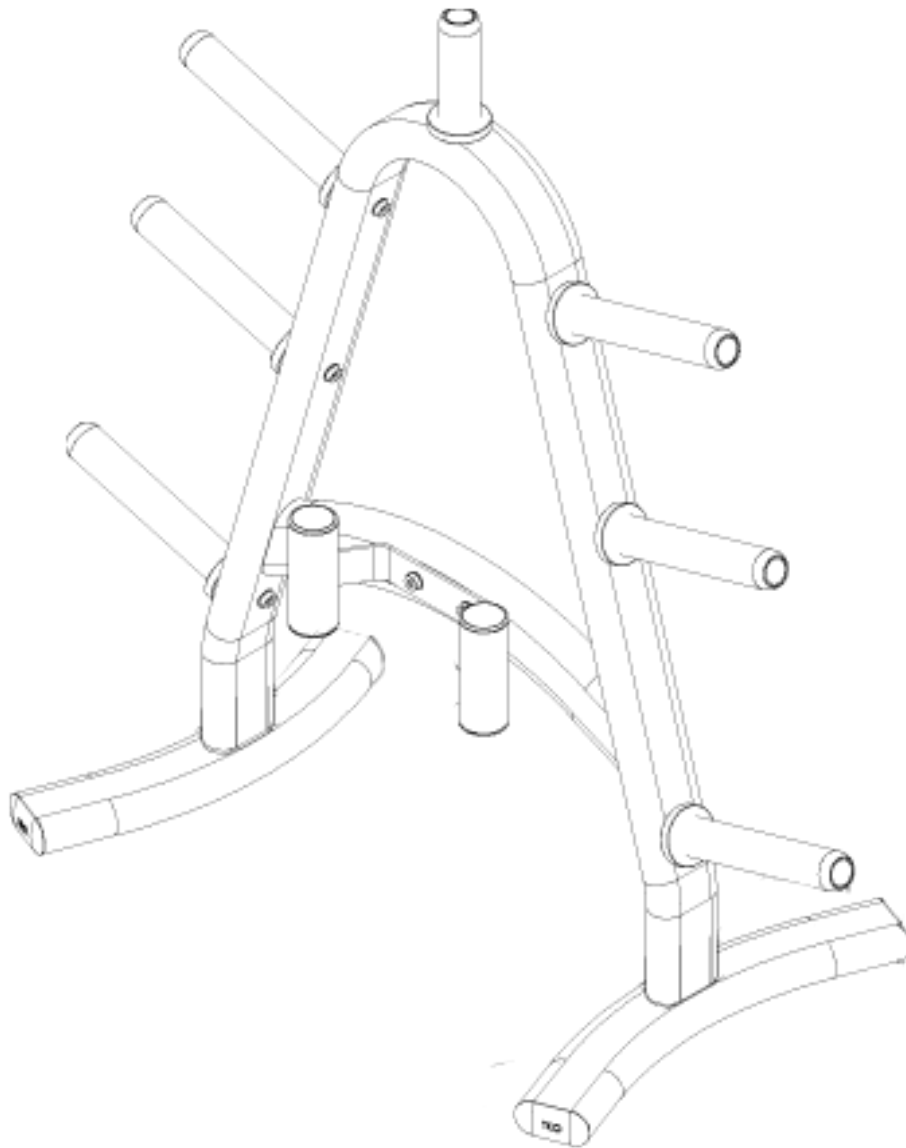

✚ Exploded Diagram

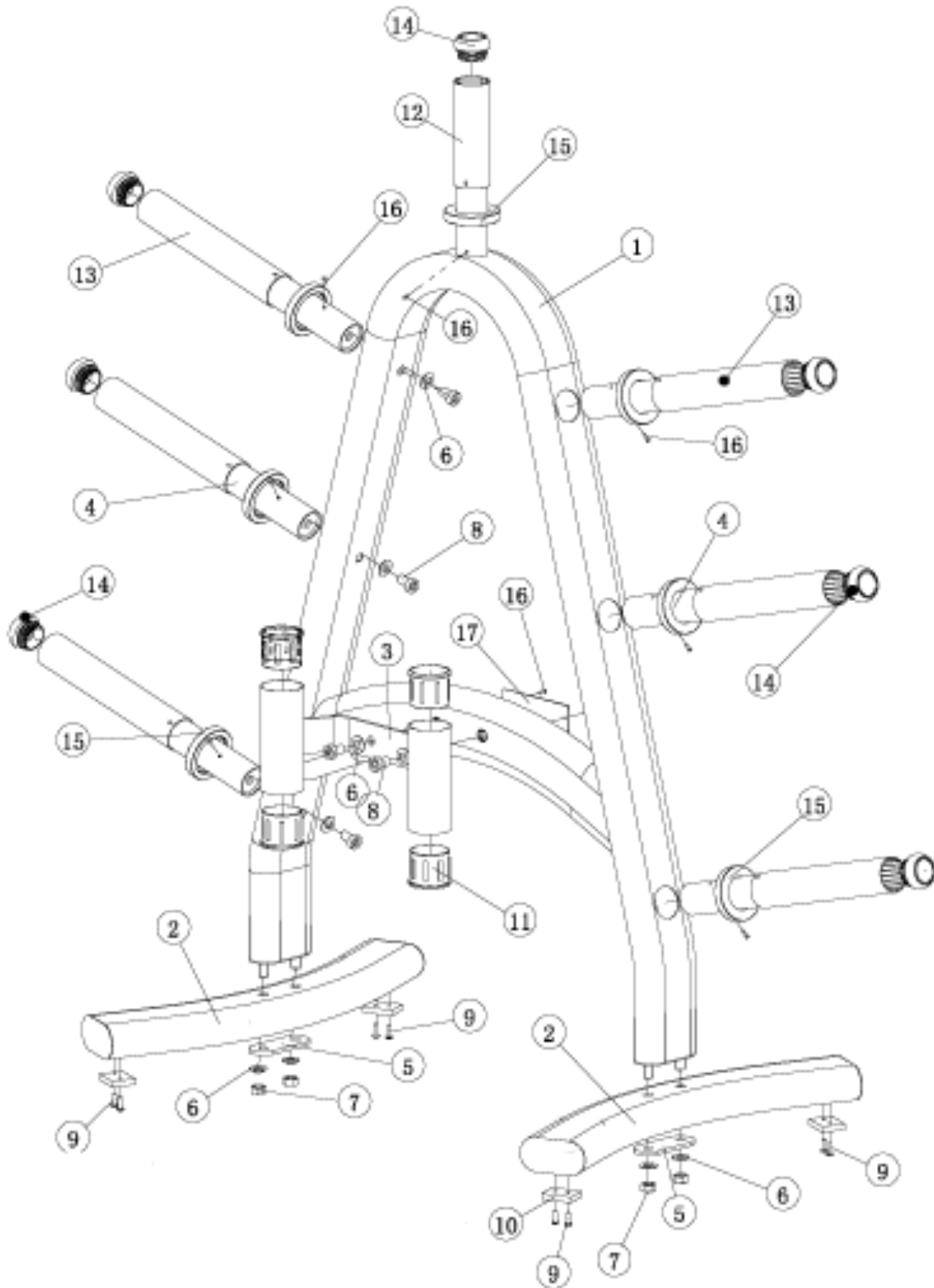

+ Parts List

No.	DESCRIPTION	Q'TY
1	Main Frame	1
2	Main Frame Stabilizer	2
3	Bar Holder	1
4	Weight Storage Bar	6
5	Metal Plate	2
6	Washer for M12 Bolt	12
7	Lock nut for M12 Bolt	4
8	Allen Bolt M12 *20mm	8
9	Phillips head Screw M5*15mm	8
10	Rubber Floor Pad	4
11	Plastic Bushing	4
12	Plastic Sleeve	1
13	Plastic Sleeves	6
14	End Cap	7
15	Rubber Bumper	7
16	Rivet	9
17	Name Plate	1

+ Assembly

Note: Before starting assembly remove all parts and hardware from the carton, ensure you have everything according to the list.

STEP 1

Connect the Main Frame Stabilizer (2) to the Main Frame (1), using 2 Metal Plates (5), 4 Washers (6) and 4 Lock Nuts (7). **Tighten all the nuts and bolts with wrench.**

STEP 2

Install the Weight Plate Storage Bar Assembly into the Holes punched in the Main Frame (1) using 1 washer (6) and 1 Allen Bolt (8), then slide the Rubber Bumper (15) onto the bottom of the Weight Storage Bar (4).

Tighten all the nuts and bolts with the Allen wrench (included).

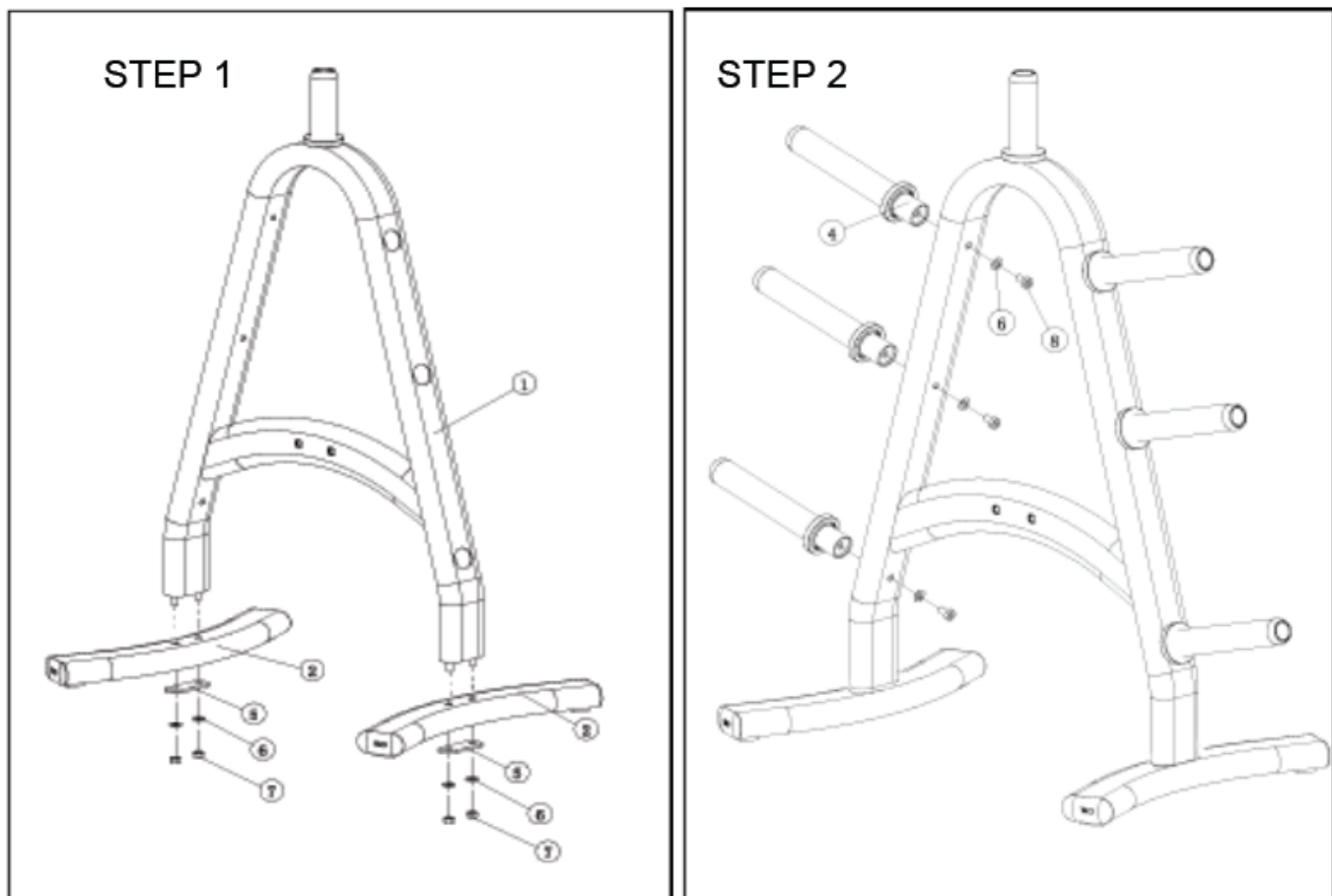

+ Assembly

STEP 3

Attach the Bar Holder (3) to the Main Frame (1), using 2 Washers (6) and 2 Allen Bolts (8).

Please tighten these 2 bolts with Allen wrench.

