

ITKO[®]

**3rd Tier For Dumbbell
Rack
Model 6251**



IMPORTANT SAFETY INSTRUCTIONS

TKO Fitness products are designed and manufactured to the highest standards in order to provide you with years of great workouts. We proudly stand behind all our products with the best customer service in the fitness industry. If you have any question or need assistance please contact us at:

Customer Service: customerservice@tko.com

Toll free: 866-856-3488 or 713-895-9270

Monday-Friday 8:30am to 4:30pm CT

- Inspect your machine prior to exercise to ensure that all nuts and bolts are fully tightened.
- Replace the worn parts immediately.
- Most exercise equipment is not recommended for small children. Children should not use the machine unless they are under adult supervision.
- Exercise equipment has moving parts. In the interest of safety, keep others, especially children, at a safe distance while exercising.
- Warm up 5 to 10 minutes before each workout and cool down 5 to 10 minutes afterward. Never hold your breath while exercising.
- Rest adequately between workouts. Muscles tone and develop during these rest periods. Beginners should work out twice a week and increase gradually to 4 to 5 times per week.
- Remove all jewelry, including rings, chains and pins before commencing exercise.
- Always wear suitable clothing and footwear during exercise. Do NOT wear loose fitting clothing that could become entangled with the moving parts of your exercise machine.

MEDICAL WARNING

- Before beginning any exercise program, consult your personal physician. Evaluate your present fitness level and determine the exercise program that is most appropriate for your particular age and condition.
- If you experience any pain or tightness in your chest, irregular heartbeats, shortness of breath, faintness or other unusual discomfort while exercising, stop and consult your physician before continuing.

EXPLODED DRAWING & PARTS LIST

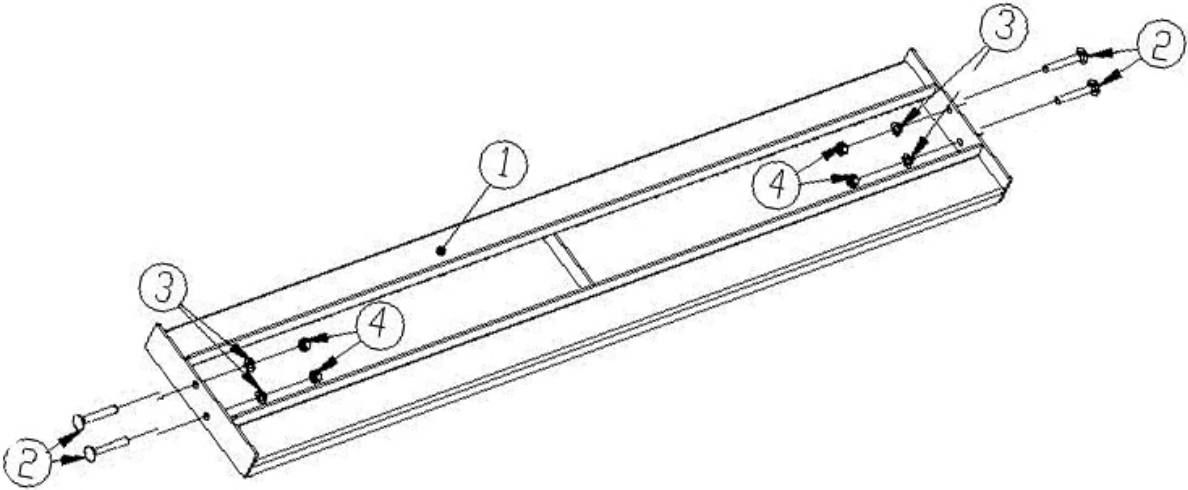

No.	Description	Q'ty
1	Dumbbell Saddle	1
2	Carriage Bolt M10x70mm	4
3	Flat Washer for M10 Bolt	4
4	Lock Nut	4



TKO SPORTS GROUP USA LTD
7354 Denny Road
Suite 100
Houston, TX 77040
866-856-3488
www.tko.com