



Standing Leg Curl

Model 720LC

+ Owner's Manual

V 1.0 - 06.2023

www.tkostrength.com

THIS PAGE INTENTIONALLY LEFT BLANK

+ Safety

Read this owner's manual carefully before assembling or using TKO equipment.

WARNING: Serious injury could occur if these safety precautions are not observed

Safety Precautions

- Before beginning any exercise program, consult your personal physician. Evaluate your present fitness level and determine the exercise program that is most appropriate for your particular age and condition.
- If you experience any pain or tightness in your chest, irregular heartbeats, shortness or breath, faintness or other unusual discomfort while exercising, stop and consult your physician before continuing.
- Make sure that the equipment(s) are set up and operated on a solid level surface. DO NOT install or use the equipment on an uneven surface.
- Exercise equipment has moving parts. In the interest of safety, keep others, especially children, at a safe distance while exercising.
- Make sure there are enough room for access and operate the equipment(s) safely.
- inspect and maintain the equipment(s) regularly.
- Replace the worn or damaged parts / components immediately to ensure safety.
- Use a spotter.
- Back support cushion may drop when knob is pulled. Hold the back support cushion when adjusting it.
- Make sure the pull pin is fully engaged before use.
- Lower the back support cushion to the lowest position when not in use.
- Warm up 5 to 10 minutes before each workout and cool down 5 to 10 minutes afterward. Never hold your breath while exercising.
- Remove all jewelry, including rings, chains and pins before commencing exercise.
- Always wear suitable clothing and footwear during exercise. DO NOT wear loose fitting clothing that could become entangled with the moving parts of your exercise machine.
- Rest adequately between workouts. Muscles tone and develop during these rest periods.
- Most exercise equipment is not recommended for small children. Children should not use the machine unless they are under adult supervision.

If you have any question or need assistance please contact us at,

Customer Service: 866-856-3488 or 713-895-9270

e mail: sales@tkostrength.com

Hours: Monday-Friday 8:30am to 4:30pm CT

© Copyright 2017, TKO Strength & Performance Inc. All rights reserved.
TKO Strength & Performance Inc. 6387 Windfern Road, Houston, TX 77040
Phone + 713-895-9270 Fax + 713-934-8495
www.tkostrength.com

+ Product Diagram



Maximum Weight Limit: 200KG / 440 lbs.

+ Instructions

Before beginning assembly please take the time to read instructions thoroughly. Please use the various lists in this manual to make sure that all parts have been included in your shipment. When ordering, use part number and description from the lists. Use only our replacement part when servicing. Failure to do so will void your warranty and could result in personal injury.

The equipment is designed to provide the smoothest, most effective exercise motion possible. After assembly, you should check all functions to ensure correct operation. If you experience problems, first recheck the assembly instructions to locate any possible errors made during assembly. If you are unable to correct the problem, call your authorized dealer. Be sure to have your serial number and this manual when calling. When all parts have been accounted for, continue on.

+ Tools Required

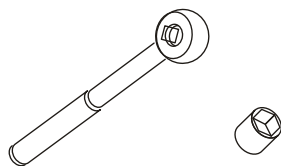

Ratchet Wrench and Socket

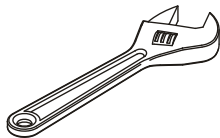

Adjustable Wrench

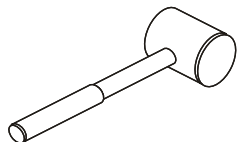

Rubber Mallet

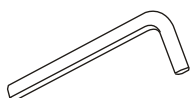

Hex Key Wrench Set

✚ Exploded Diagram

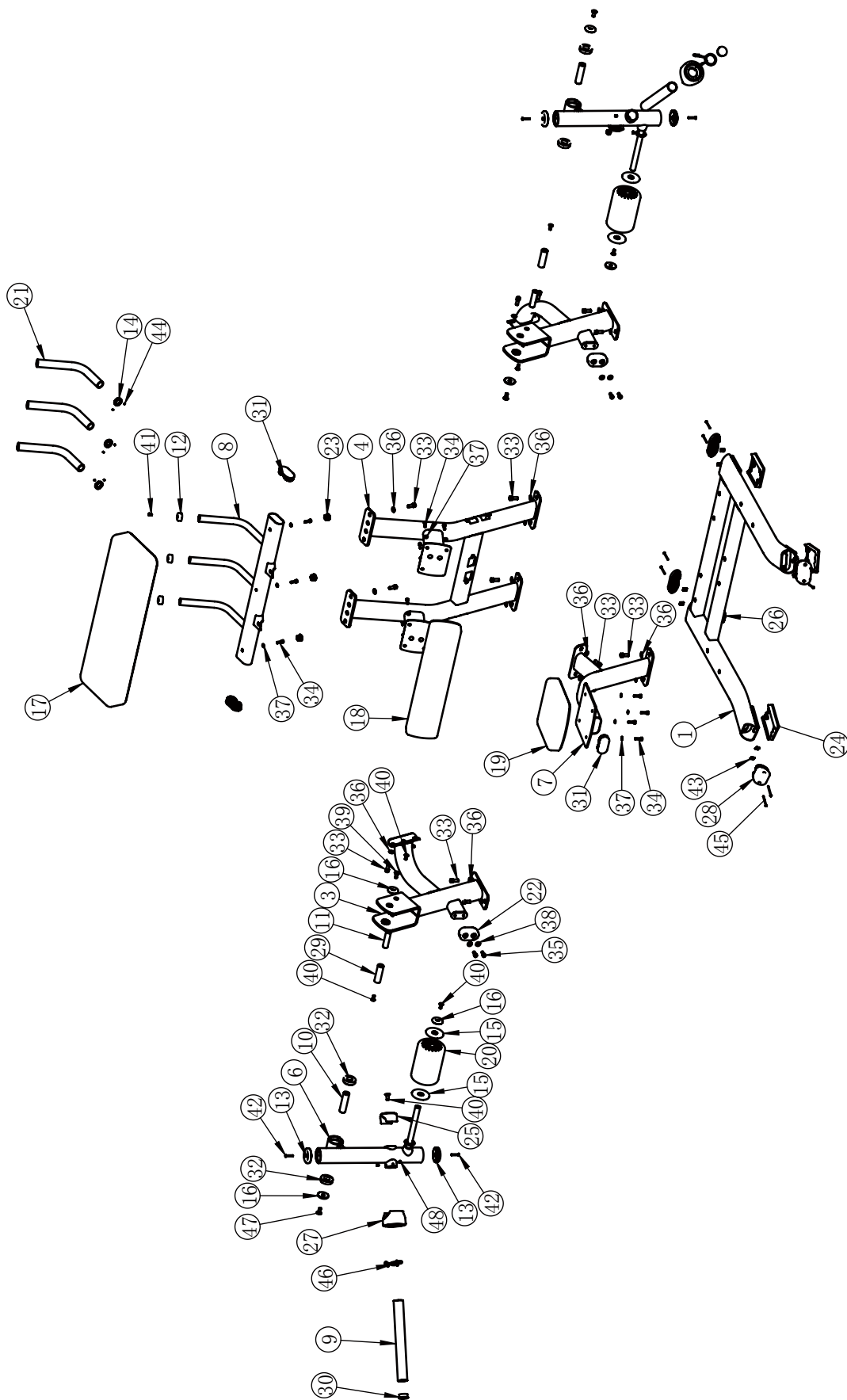

+ Parts List

NOTE: SOME OF THESE PARTS MAY COME PRE-INSTALLED

ITEM NO.	DESCRIPTION	QTY	ITEM NO.	DESCRIPTION	QTY
1	Base Frame	1	25	Outer Safty Cover Assembly	2
2	Right Upright Frame	1	26	Adjustable Foot	1
3	Left Upright Frame	1	27	Bumper	2
4	Main Frame	1	28	Plug PT60×120	4
5	Right Arm Frame	1	29	Grip	2
6	Left Arm Frame	1	30	Aluminum Plug Plate φ48	2
7	Knee Pad Frame	1	31	Plug RT50×100	3
8	Elbow Pad Frame	1	32	Ball Bearing	4
9	Weight Horns	2	33	Socket Head Cap Screw M12×30	20
10	Arm Pivot Axle	2	34	Socket Head Cap Screw M8×30	13
11	Limit Shaft	2	35	Socket Head Cap Screw M10×30	4
12	Aluminum Cap	3	36	Flat Washer	20
13	Aluminum Cap φ76	4	37	Flat Washer	13
14	Aluminum Spacer Ring	3	38	Flat Washer	4
15	Aluminum Ring Ø25	4	39	Flat Head Cap Screw M12×30	4
16	Aluminum Cap	6	40	Flat Head Cap Screw M10×25	6
17	Elbow Pad	1	41	Flat Head Cap Screw M6×16	3
18	Leg Pad	1	42	Flat Head Cap Screw M6×30	4
19	Knee Pad	1	43	Nut 13.68×21×M5	8
20	Foam	2	44	Socket Set Screw M5×3	6
21	Grip	3	45	Phillip Screw M5×60	8
22	Bumper	2	46	Snap Spring	2
23	Plug	3	47	Flat Head Cap Screw M12×30	2
24	Rubber Foot	3	48	Socket Set Screw M8×6	4

+ Measurement Guide

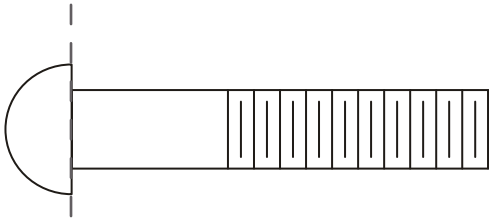

BHCS = Button Head Cap Screw

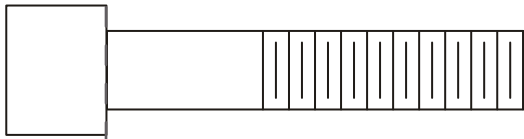

SHCS = Socket Head Cap Screw

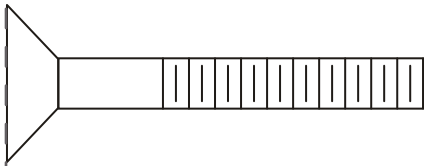

FHCS = Flat Head Cap Screw

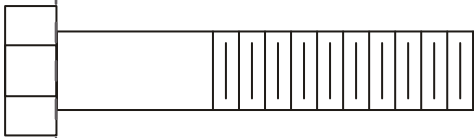

HHB = Hex Head Bolt

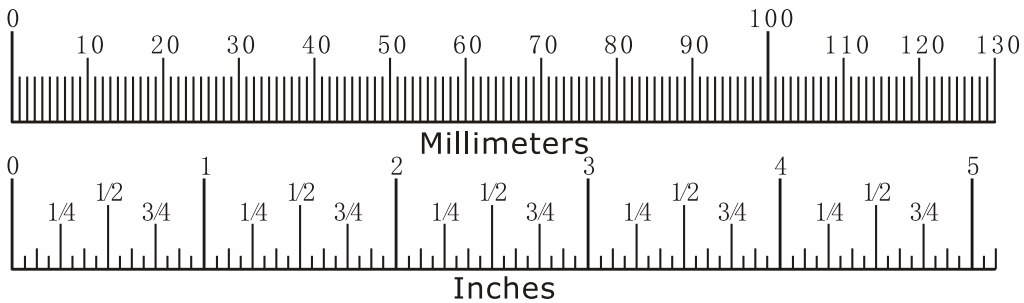

+ Assembly Instruction

Assembly of the equipment takes professional installers about 2 hours. If this is the first time you have assembled this type of equipment, plan to spend more time. It is strongly recommended to assemble the equipment by professional installers. You may find it quicker, safer, easier to assemble this equipment with the help of a friend, as some of components may be large, heavy or awkward to handle alone. It is important that you assemble your product in a clean, clear, uncluttered area. This will enable you to move around the product while you are fitting components and reduce the possibility of injury during assembly.

NOTE

As with any assembled part, proper alignment and adjustment is critical. While tightening the fasteners, be sure to leave room for adjustments. Do not fully tighten the fasteners until instructed to do so. Be careful to assemble the components in the sequence presented in this guide.

+ Assembly

STEP 1

ITEM NO.	DESCRIPTION	QTY
1	base Frame	1
2	Right Upright Frame	1
3	Left Upright Frame	1
4	Main Frame	1
33	Socket Head CapScrew M12×30	8
36	Flat Washer	8

Note: Hand Tighten Bolts and Nylon Lock Nuts.

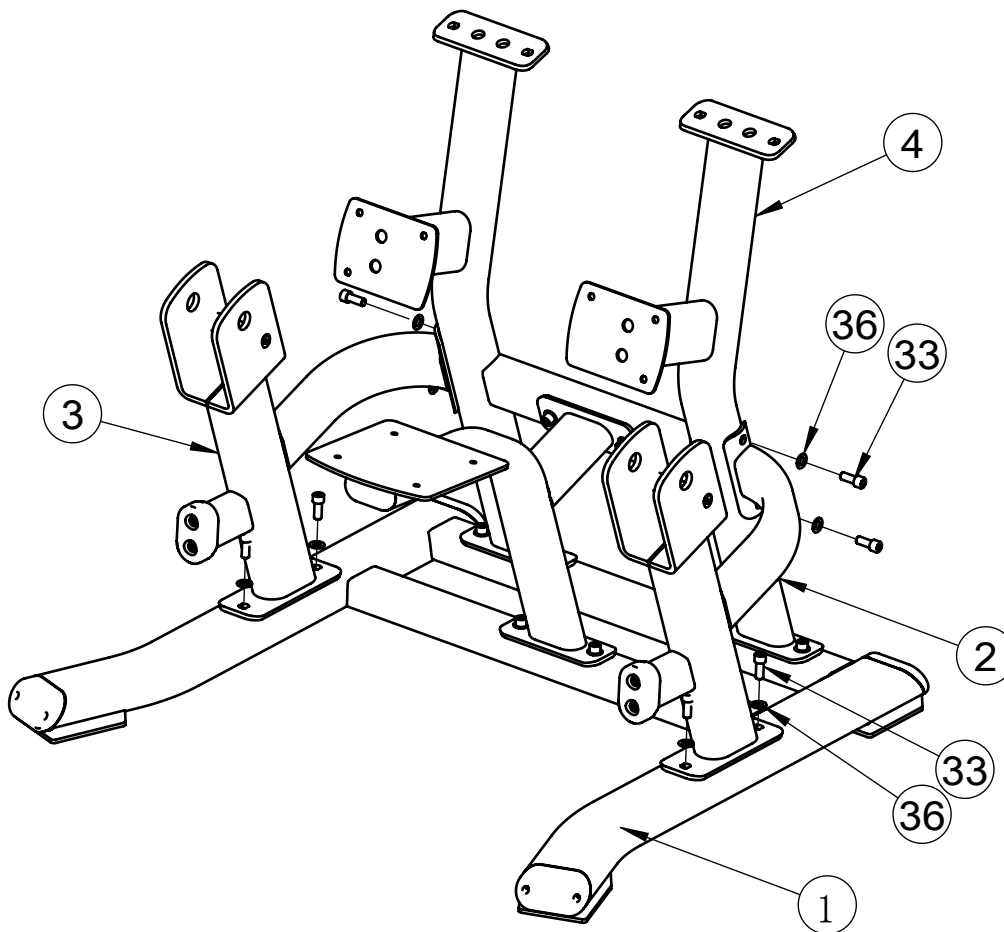

+ Assembly

STEP 2

ITEM NO.	DESCRIPTION	QTY
3	Left Upright Frame	1
4	Main Frame	1
6	Left Arm Frame	1
8	Elbow Pad Frame	1
9	Weight Horns	1
10	Arm Pivot Axle	1
16	Aluminum Cap	2
25	Outer Safty Cover Assembly	1
27	Bumper	1
30	Plug $\phi 48$	1
32	Ball Bearing	2
33	Socket Head Cap Screw M12*30	4
36	Flat Washer	4
39	Flat Head Cap Screw M12*30	2
40	Flat Head Cap Screw M10*25	1
46	Snap Spring	2
47	Socket Set Screw M8*10	2

Note: Hand Tighten Bolts and Nylon Lock Nuts.

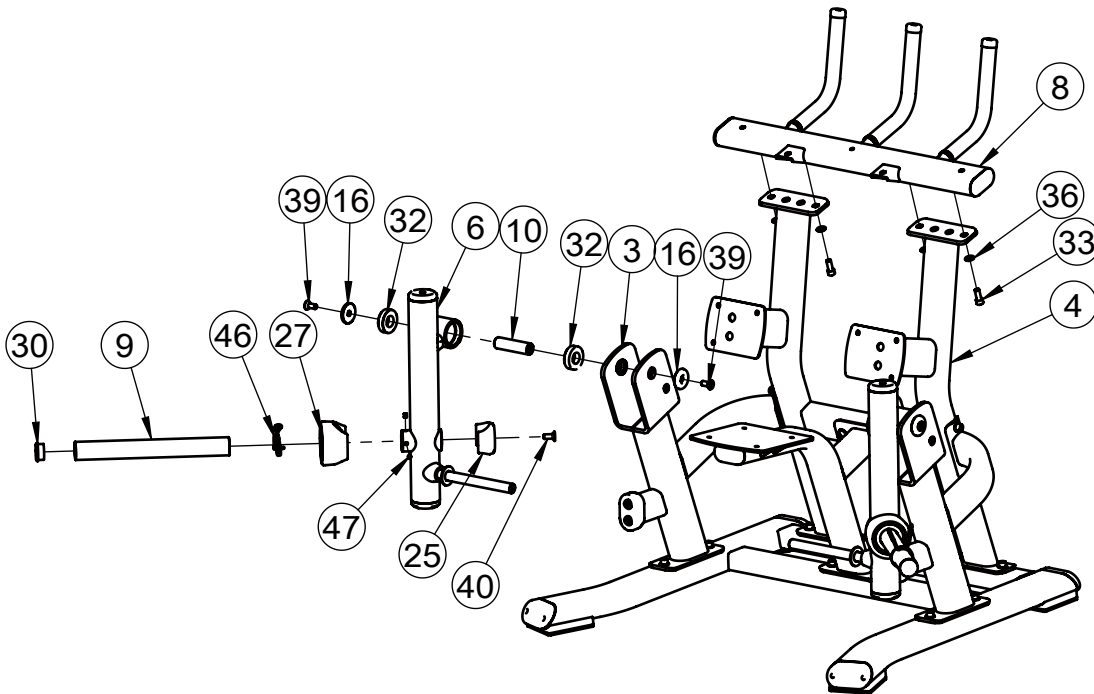

+ Assembly

STEP 3

ITEM NO.	DESCRIPTION	QTY
4	Main Frame	1
6	Left Arm Frame	1
7	Knee Pad Frame	2
8	Elbow Pad Frame	1
15	Aluminum Ring $\Phi 25$	1
16	Aluminum Cap	1
17	Elbow Pad	1
18	Leg Pad	1
19	Knee Pad	1
20	Foam	1
23	Plug	3
34	Socket Head Cap Screw M8*30	7
37	Flat Washer	7
41	Flat Head Cap Screw M6*16	1

Note: Hand Tighten Bolts and Nylon Lock Nuts.

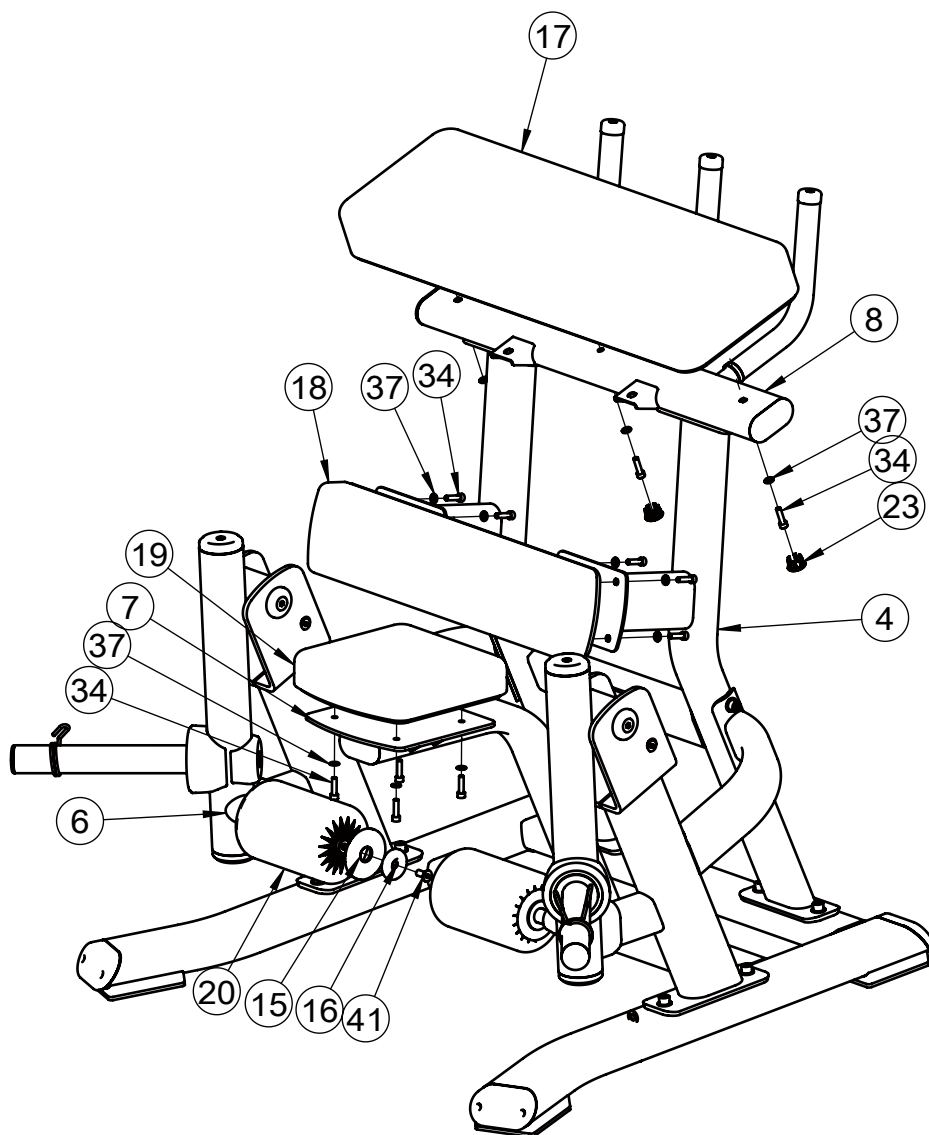

✚ Maintenance Schedule

ROUTINE	COMMERCIAL MAINTENANCE	HOME MAINTENANCE	LATEST DATE ENTRY					
Inspect; Links, Pull Pins, Snap Locks, Swivels, Weight Stack Pins	DAILY	WEEKLY						
Clean; Upholstery	DAILY	WEEKLY						
Inspect; Cables or Belts and their tension	DAILY	WEEKLY						
Inspect; Accessory Bars, and Handles	WEEKLY	3 MONTHS						
Inspect; All Decals	WEEKLY	3 MONTHS						
Inspect; All Nuts and Bolts, Tighten if needed	WEEKLY	3 MONTHS						
Inspect; Anti-Skid Surface	WEEKLY	3 MONTHS						
Clean & Lubricate; Guide Rods with a Teflon (PTFE) based lubricant (Superlube)	MONTHLY	3 MONTHS						
Lubricate; Seat Sleeves, Turcite Bushings, Linear Bearing	MONTHLY	3 MONTHS						
Clean and Wax; All Glossy Finishes	6 MONTHS	YEARLY						
Repack with Grease; Linear Bearings	6 MONTHS	YEARLY						
Replace; Cables, Belts and Connecting Parts	YEARLY	3 YEARS						

Your equipment comes with a commercial maintenance decal. For personal, in home use, please follow the home maintenance schedule listed above.

+ General Maintenance Information

Links, Pull-Pins, Snap Hooks, Swivels, Weight Stack Pins:

- * Check all pieces for signs of visible wear or damage.
- * Check springs in snap hooks and pull-pins for proper tension and alignment.
- * If the spring sticks or has lost its rigidity, replace it immediately.

Upholstery:

- * To ensure prolonged upholstery life and proper hygiene, all upholstered pads should be wiped down with a damp cloth after every workout.
- * Periodically take the time to use a mild soap or an approved vinyl upholstery cleaner to deter the onset of cracking or drying. Avoid using any abrasive cleaners or cleaners not intended for use on vinyl.
- * Replace ripped or worn upholstery immediately.
- * Keep sharp or pointed objects clear of all upholstery.

Decals:

- * Inspect and familiarize yourself with any safety warnings or other user information posted on each decal.

Nuts and Bolts:

- * Inspect all nuts and bolts for any loosening and tighten if needed.
- * Go through a re-tightening sequence periodically to ensure that all hardware is tensioned proper.

Anti-Skid Surfaces:

- * These surfaces are designed to supply secure footing and need to be replaced if they appear worn or become slippery.

Belts and Cables:

- * We use only high quality belt, and mil-spec cables.
- * Visually inspect the belts and cables for fraying, cracking, peeling or discoloration.
- * While the machine is not in use, carefully run your fingers along the belt or cable to feel for thinning or bulging areas.
- * Replace belts and cables immediately at the first signs of damage or wear. Do not use equipment until belts or cables have been replaced.

Belt and Cable Tension:

- * Referring to the Owners Manual, when belts or cables are used check all bolts attachments to be sure they are properly attached.
- * Check slack in cables and re-adjust cable tension if needed.

Seat Sleeves, Guide Rods:

- * Wipe down adjusting tubes with a dust free rag before applying lubricant.
- * Lubricate seat sleeves and Guide Rods with a Silicon or Teflon based lubricant spray.

Linear Bearings:

- * Referring to the Owners Manual carefully disassemble the bearing from its housing and place a finger full of light grease (lithium, super lube, etc.) into the inside of the bearing. Using your finger, press the grease into the ball-bearings and their tracks. Repeat until the ball-bearing tracks are full of grease. Insert the shaft back into the bearing and wipe off excess grease.