

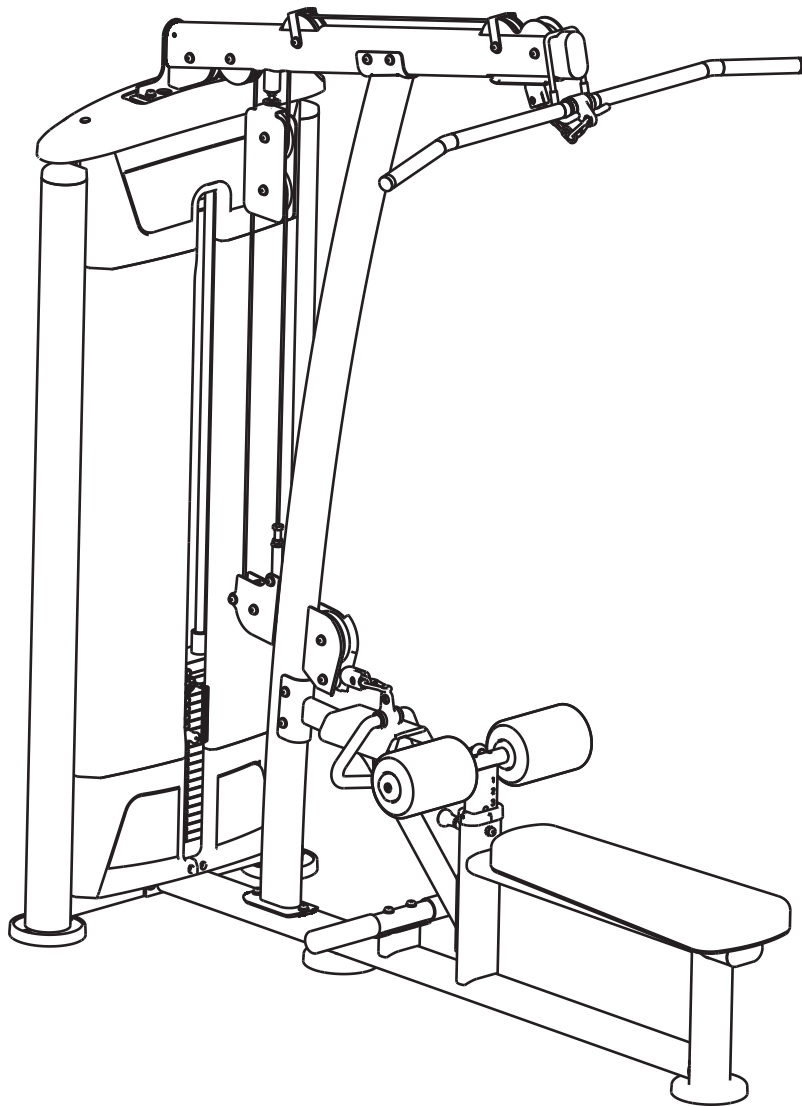

7061-G2

LAT PULLDOWN/VERTICAL ROW

Owner's Manual



! CAUTION

Read all precautions
and instructions in this manual
before using this equipment

Table Of Contents

CAUTION!

Read all precautions and instructions in this manual before using this equipment.

Important Safety Instructions-----	3
Instructions-----	5
Exploded View and Parts List-----	6
Measurement Guide-----	13
Assembly Instructions-----	14
Assembly-----	15
Adjust Instructions-----	28
Exercise Instructions-----	29
Maintenance Schedule-----	30
General Maintenance Information-----	31
Weight Training Tips-----	32

Please assemble according to the actual **Weights** you buy !

Important Safety Instructions

Before beginning any fitness program, you should obtain a complete physical examination from your physician. When using exercise equipment, basic precautions should always be taken, including the following:

1. Read all instructions before using the equipment.
These instructions are written to ensure your safety and to protect the unit.
2. Use the equipment only for its intended purpose as described in this guide.
Do not use accessory attachments that are not recommended by the manufacturer: such attachments might cause injuries.
3. The product should only be used on a level surface and is with 0.5 meters space around the product.
Do not use the equipment outdoors.
4. Do not allow children on or near the equipment. And children are not allowed to use this equipment.
Teenagers should use this equipment with adult supervision.
5. Do not overexert yourself or work to exhaustion.
Do not attempt to lift more weight than you can control safely.
If you feel any pain or abnormal symptoms, stop your workout immediately and consult your physician.
6. This equipment is not used as medical apparatus and instruments.
7. Never operate the unit when it has been dropped or damaged.
Never drop or insert anything into any opening in the equipment.
Always check the unit and its cables before each use. Make sure that all fasteners and cables are secure and in good working condition.
Frayed or worn cables can be dangerous and may cause injury. Periodically check these cables for any indication of wear.
Keep hands, limbs, loose clothing and long hair well out of the way of moving parts.
8. Be careful when getting on or off the equipment.
9. Wear proper exercise clothing and shoes for your workout, no loose clothing.

Important Safety Instructions

Personal Safety During Assembly

Read each step in the assembly instructions and follow the steps in sequence. Do not skip ahead. If you skip ahead, you may learn later that you have to disassemble components and that you may have damaged the equipment.

Assemble and operate the equipment on a solid, level surface. Locate the unit a few feet from walls or furniture to provide easy access. The equipment is designed for your enjoyment. By following these precautions and using common sense, you will have many safe and pleasurable hours of healthful exercise with the equipment.

Training Area and Free Area

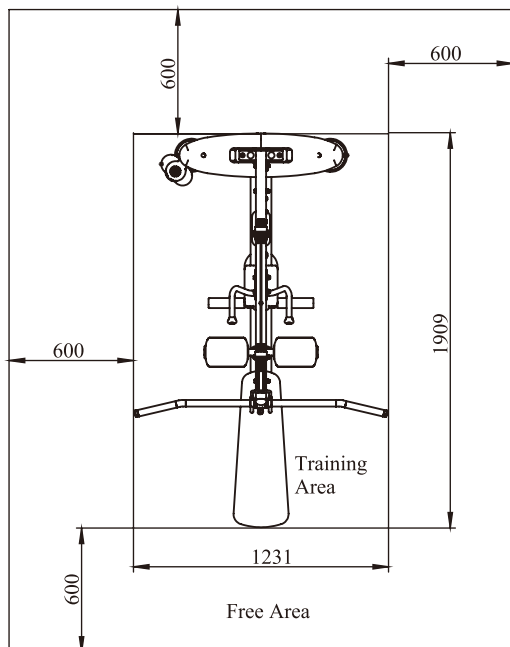

Specifications

Class: S

Maximum Wt. Capacity: 134kg/ 295lbs

Maximum User Weight: 150kg/ 330lbs

Product Total Surface: 1231*1909mm

Product Total Mass: 131.6 kg/ 290 lbs

Instructions

Before beginning assembly please take the time to read instructions thoroughly. Please use the various lists in this manual to make sure that all parts have been included in your shipment. When ordering, use part number and description from the lists. Use only our replacement part when servicing. Failure to do so will void your warranty and could result in personal injury.

The equipment is designed to provide the smoothest, most effective exercise motion possible. After assembly, you should check all functions to ensure correct operation. If you experience problems, first recheck the assembly instructions to locate any possible errors made during assembly. If you are unable to correct the problem, call your authorized dealer. Be sure to have your serial number and this manual when calling. When all parts have been accounted for, continue on.

Tools Required

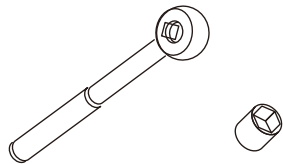

Ratchet Wrench and Socket

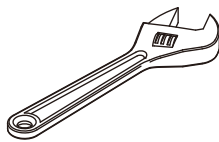

Adjustable Wrench



Rubber Mallet



Hex Key Wrench Set

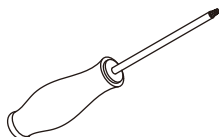

Phillips Screwdriver

Exploded View and Parts List

Overall

ItemNo.	Grade No.	Part No.	Description	QTY
1	1	IT952201ASSY	Weight Stack Frame ASSY	1
2	2	IT952202ASSY	Seated Frame ASSY	1
3	3	IT952203ASSY	Front Frame ASSY	1
4	4	IT952204ASSY	FOAM Frame ASSY	1
5	5	IT952205ASSY	Top Frame ASSY	1
6	6	IT95220600	Support Frame	1
7	8	IT95220800	Handle Frame	1
8	9	IT951709ASSY	Circular Foot Frame ASSY	1
9	10	FS531300	Pulley Bracket	1
10	11	IT90222400	U Bracket	2
11	12	IT95223100	Lat Pull Cable	1
12	13	IT95223200	Row Cable	1
13	14	SD1000B3000ASSY	Adjustable Foot Plate	2
14	15	SG500110400V5	4.5" Pulley	9
15	16	FTX7300V1	2" Pulley	1
16	17	V30900V1	Long Lat Bar	1
17	18	IT952218ASSY	Lat Bar ASSY	1
18	19	IN-D10132900	Weight Rubber Bumper	2
19	23	IT952223ASSY	Rear Bracket ASSY	1
20	24	IT952224ASSY	Front Bracket ASSY	1
21	25	IT952225ASSY	Bottom Bracket ASSY	1
22	26	IT95222600	Top Bracket	2
23	27	IT95222700	Bottom Bracket	1
24	42	IT95014200	Top Plate	1
25	44	IT95224400	Guide Rod Φ 19*1597	2
26	51	IT95225100	Top Cover	1
27	52	IT95015200	Training Placard Cover	1
28	53	IT95015300	Front Shroud	2
29	55	IT95015500	Top Rear Shroud	1
30	56	IT95015600	Rear Shroud	1
31	60	IT95225500	Bottom Rear Shroud	1
32	61	IT95226100	Right Shroud	1
33	62	IT95226200	Left Shroud	1

Exploded View and Parts List

Overall

Item No.	Grade No.	Part No.	Description	QTY
34	76	IT95227600	Seat Pad	1
35	77	IE950221ASSY	FOAM ASSY	2
36	92	IT801210300P11C	Cup Holder	1
37	101	IT90012000V1	Selector Pin W/Coil	1
38	102	IT95016100	Guide Rod Fixing Sleeve $\Phi 25^* \Phi 19^*45$	2
39	103	IT95016500	Spout Plug $\Phi 16.5^*6.88$	2
40	104	HFOPT900-04A0602	Spring	2
41	105	IT95062000	Cap ASSY	2
42	106	HLG8DS2	Gear Hook	2
43	107	LH $\Phi 5^*5DS2$	Chain	1
44	108	IE95029100	Plastic Ring	2
45	109	GB70BTM10*80DN18	Socket Head Cap Screw M10*80	2
46	110	GB70BTM10*75DN18	Socket Head Cap Screw M10*75	2
47	111	GB70BTM10*70DN18	Socket Head Cap Screw M10*70	6
48	112	GB70BTM10*65DN18	Socket Head Cap Screw M10*65	5
49	113	GB70BTM10*50DN18	Socket Head Cap Screw M10*50	6
50	114	GB70BTM10*25DN18	Socket Head Cap Screw M10*25	7
51	115	GB9310DS12	Spring Washer $\Phi 10$	4
52	116	GB5781M10*15DS20NL	Hex Head Bolt M10*15	2
53	117	PNLM8*70DS20	Button Socket Head Cap Screw M8*70	2
54	118	GB70M8*20N19	Socket Head Cap Screw M8*20	2
55	119	GB70M8*10DS2	Socket Head Cap Screw M8*10	2
56	120	GB818M6*20DHS2	Cross Recessed Pan Head Screw M6*20	24
57	121	GB818M6*10DHS2	Cross Recessed Pan Head Screw M6*10	8
58	122	NM10DN2	Nylon Lock Nut M10	17
59	123	NM8DN2	Nylon Lock Nut M8	2
60	124	GB958DN2	Flat Washer $\Phi 9^* \Phi 16^*1.6$	8
61	125	GB9510DN2	Flat Washer $\Phi 11^* \Phi 20^*2$	44
62	126	NBS0.188DHS	Hex Key S=3/16"	1
63	127	NBS5DHS	Hex Key S=5	1
64	128	NBS6DHS	Hex Key S=6	1
65	129	LW200BS	Wrench $\Phi 6^*117$	1
66	130	YHY	Lube	1

Exploded View and Parts List

Overall

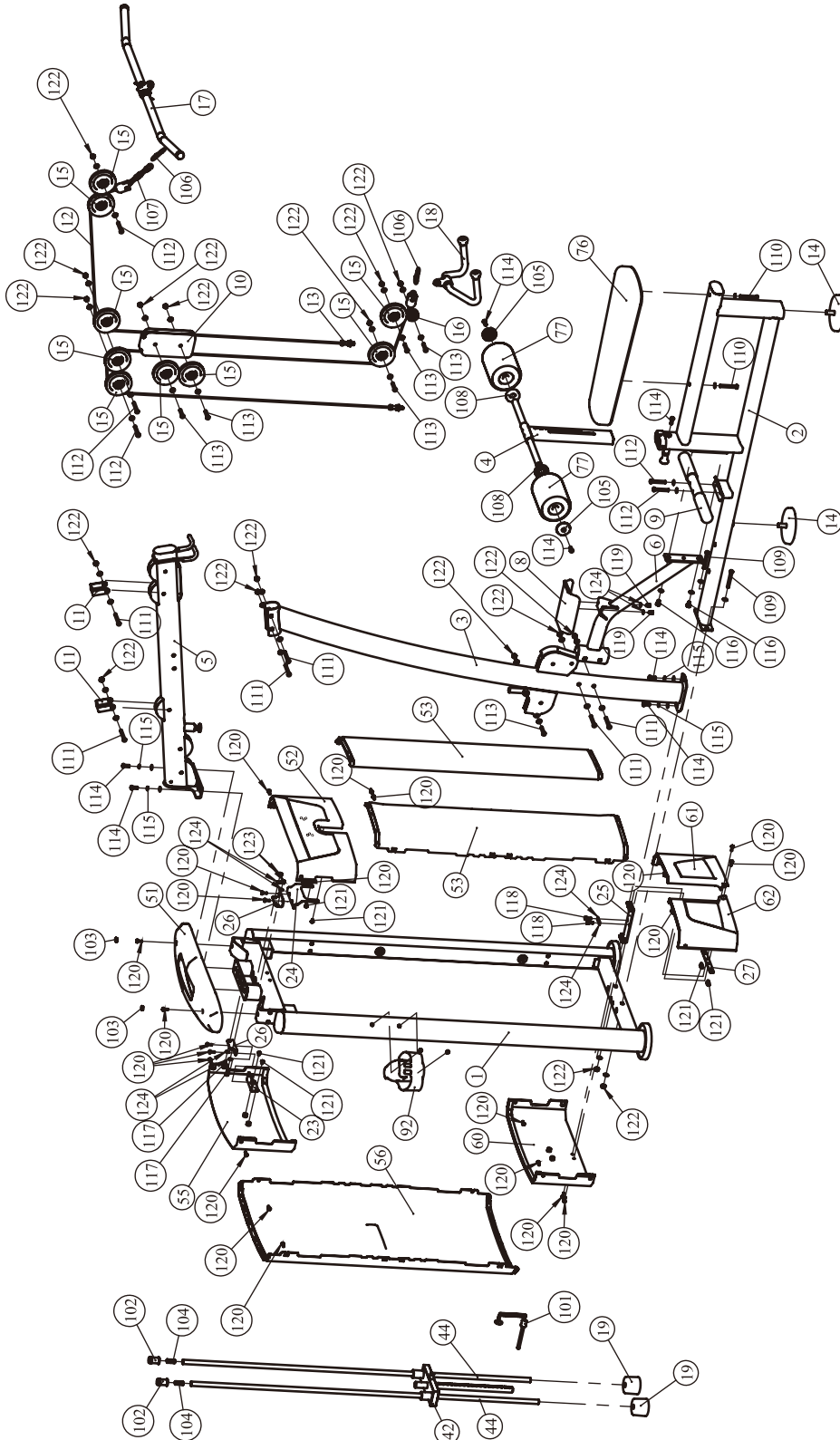

Exploded View and Parts List

Weight Stack Frame ASSY

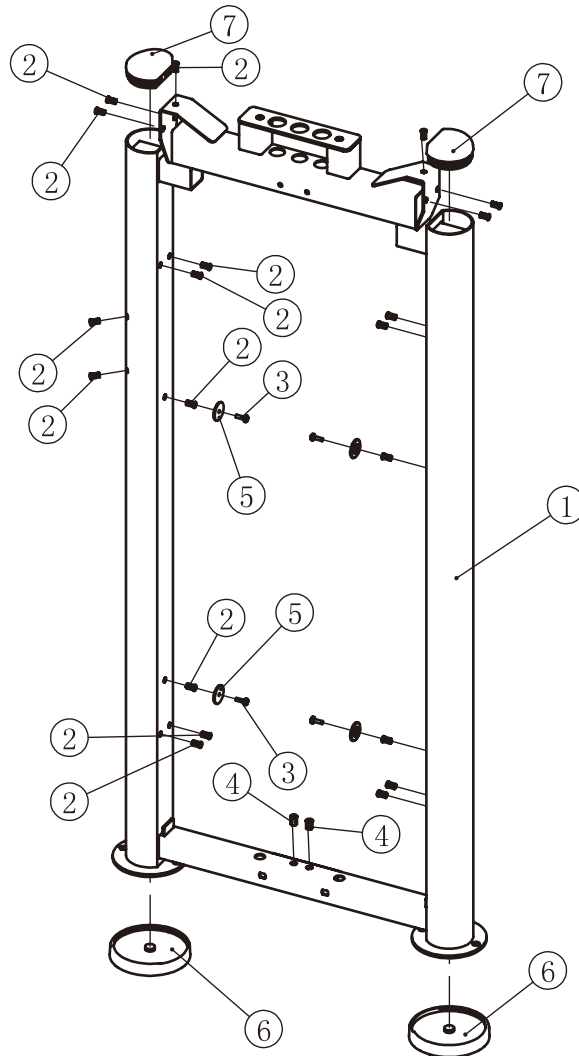

ItemNo.	Grade No.	Part No.	Description	QTY
1	1.1	IT95220100	Weight Stack Frame	1
2	1.2	GB17880.5M6*16.5DS17	Rivet Nut M6	20
3	1.3	GB818M6*20DHS2	Cross Recessed Pan Head Screw M6*20	4
4	1.4	GB17880.5M8*16.5DCS17	Rivet Nut M8	2
5	1.5	IT95015900	Plastic Block	4
6	1.6	IT95015700	Foot Plate	2
7	1.7	IT95015800	Plug $\Phi 95*81.1$	2

Exploded View and Parts List

Seated Frame ASSY

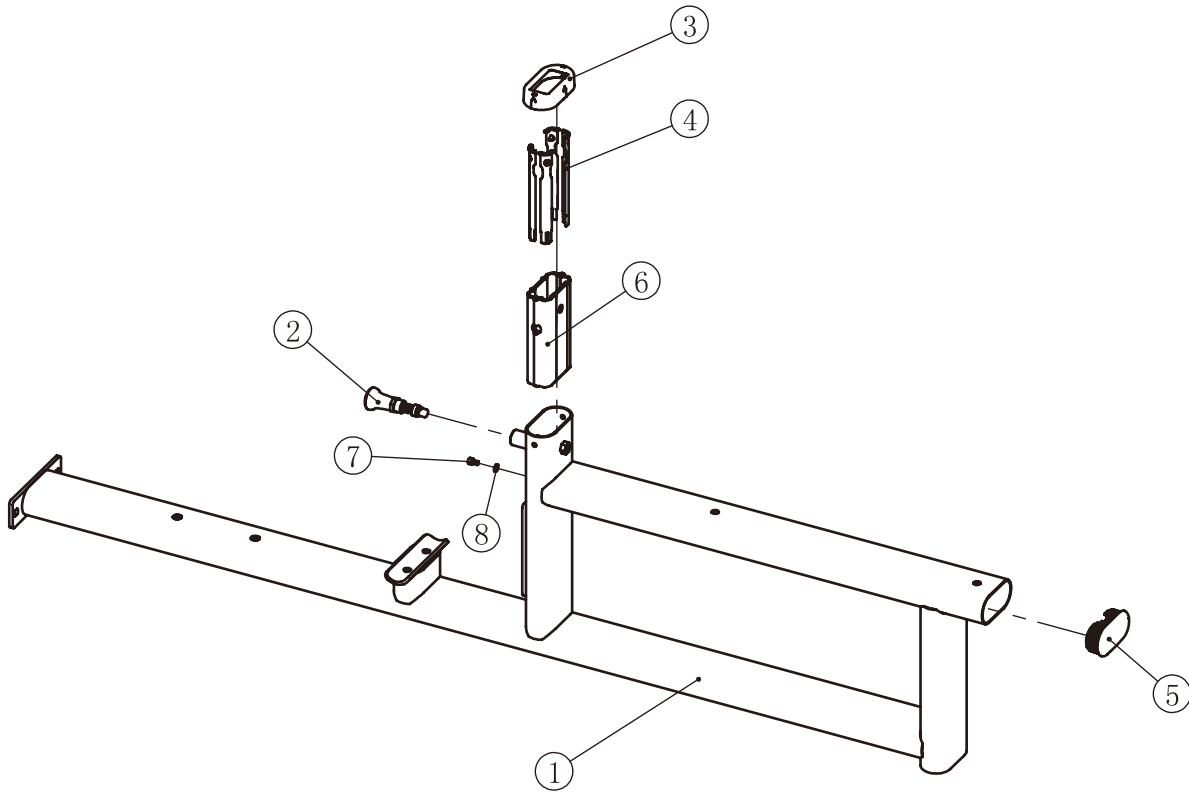

ItemNo.	Grade No.	Part No.	Description	QTY
1	2.1	IT95220200	Seated Frame	1
2	2.2	IT95221700	Pin	1
3	2.3	IT95016200	Plastic Tube Plug	1
4	2.4	IT95016300	Plastic Corner Tube Glide	4
5	2.5	IT90013800P11C	Plug RT50*100	1
6	2.6	IT95014300	Aluminum Tube Guide	1
7	2.7	GB70M6*10N19	Socket Head Cap Screw M6*10	1
8	2.8	GB956DN2	Flat Washer $\Phi 6.6 * \Phi 12 * 1.6$	1

Exploded View and Parts List

Front Frame ASSY

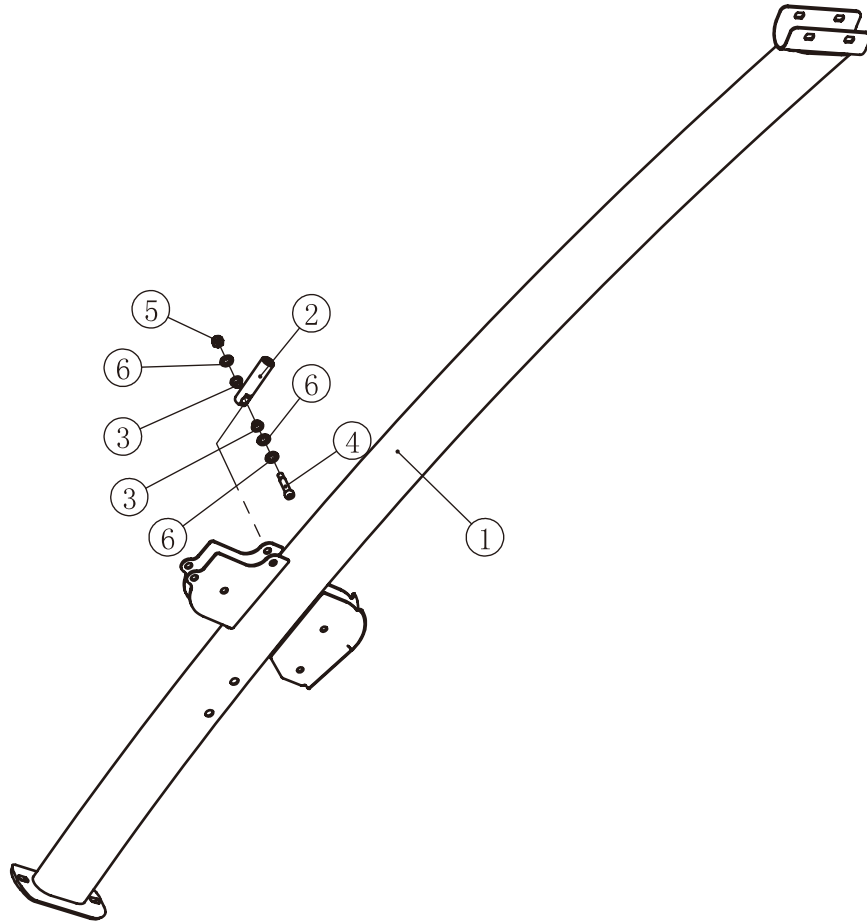

ItemNo.	Grade No.	Part No.	Description	QTY
1	3.1	IT95220300	Front Frame	1
2	3.2	AP55600	Adjustable End	1
3	3.3	BNH0738	Bushing	2
4	3.4	IF81105500V1	Bolt $\Phi 9.4*47.5*M8$	1
5	3.5	NM8DN2	Nylon Lock Nut M8	1
6	3.6	GB9510DN2	Flat Washer $\Phi 11*\Phi 20*2$	3

Exploded View and Parts List

Top Frame ASSY

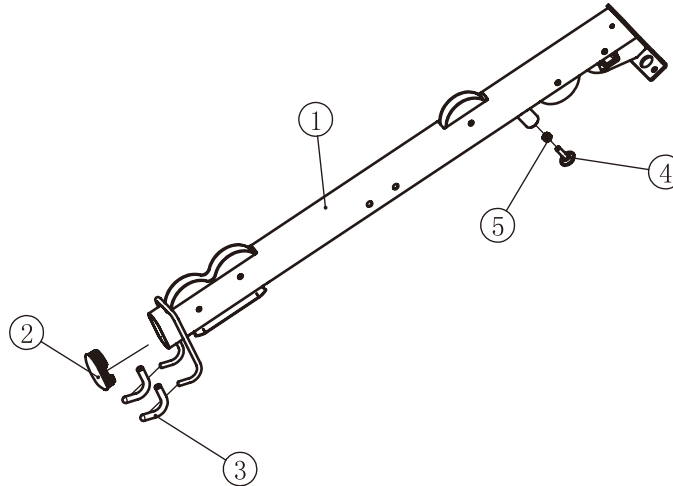

ItemNo.	Grade No.	Part No.	Description	QTY
1	5.1	IT95220500	Top Frame	1
2	5.2	IT90013800P11C	Plug RT50*100	1
3	5.3	HF900-03A1700P116C	Grip	2
4	5.4	DC135K34000	Adjustable Stopper	1
5	5.5	GB41M10N19	Hex Nut M10	1

Lat Bar ASSY

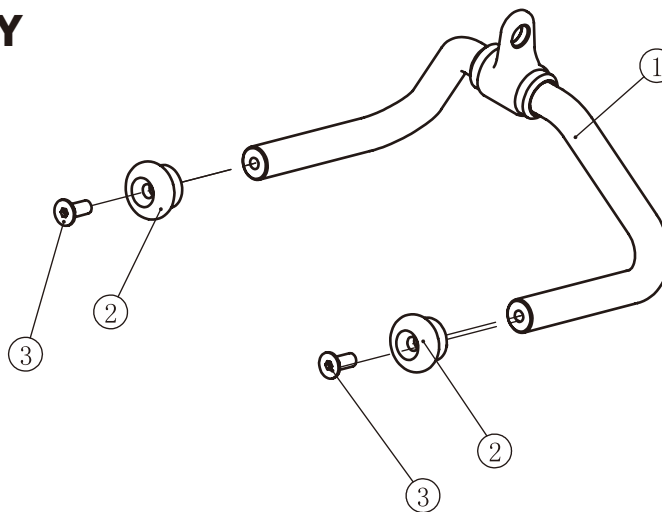

ItemNo.	Grade No.	Part No.	Description	QTY
1	18.1	SD1002B1000	Lat Bar	1
2	18.2	IT90102100	Aluminium Grip Cap	2
3	18.3	CNLM10*30*30DS20NL	Flat Head Cap Screw M10*30	2

Measurement Guide

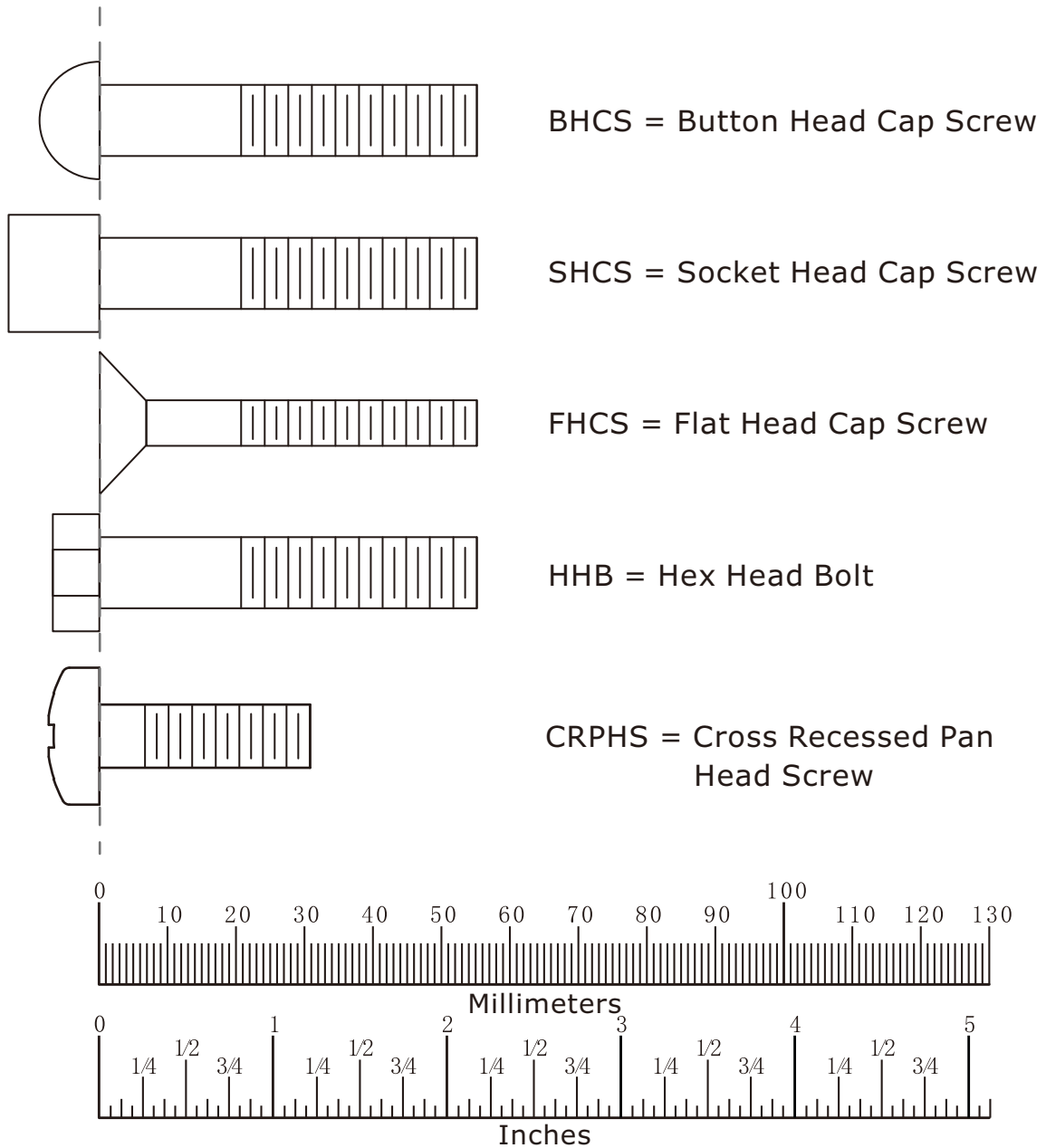

Diameter of bolt (mm/inch)	M6(1/4")	M8(5/16")	M10(3/8")	M12(1/2")	M16(5/8")
Tightening torque (N.m)	9~12	22~30	45~59	78~104	193~257
Operational methods for adult men	The strength of the wrist	The strength of the wrist and forearm	The strength of the entire arm	The strength of the arm and upper body	with all strength

Assembly Instructions

Assembly of the equipment takes professional installers about 2 hours. If this is the first time you have assembled this type of equipment, plan to spend more time. It is strongly recommended to assemble the equipment by professional installers. You may find it quicker, safer, easier to assemble this equipment with the help of a friend, as some of components may be large, heavy or awkward to handle alone. It is important that you assemble your product in a clean, clear, uncluttered area. This will enable you to move around the product while you are fitting components and reduce the possibility of injury during assembly.

NOTE

As with any assembled part, proper alignment and adjustment is critical. While tightening the fasteners, be sure to leave room for adjustments. Do not fully tighten the fasteners until instructed to do so. Be careful to assemble the components in the sequence presented in this guide.

Assembly

STEP 1

1. Attach two Adjustable Foot Plates (#14) to the Seated Frame ASSY (#2).
2. Attach the Rear Bracket ASSY (#23) to the Top Rear Shroud (#55) using:
two M6*10 CRPHS (#121)
3. Attach the Front Bracket ASSY (#24) to the Training Placard Cover (#52) using:
two M6*10 CRPHS (#121)
4. Attach the Bottom Bracket (#27) to the Right Shroud (#61) and the Left Shroud (#62) using:
four M6*10 CRPHS (#121)

Note: Wrench Tighten Bolts.

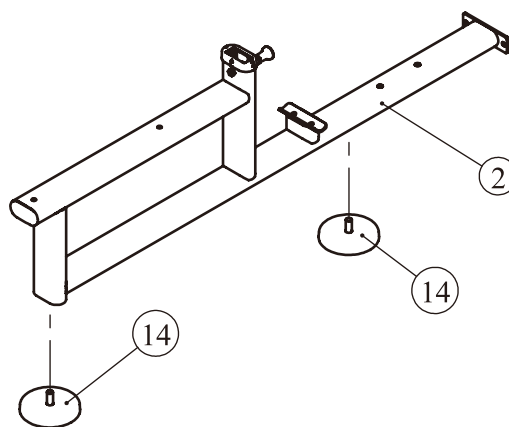
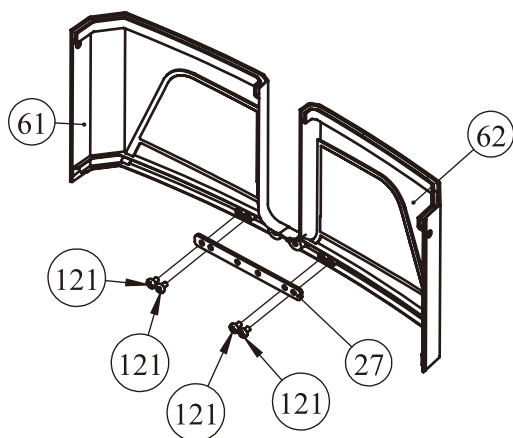
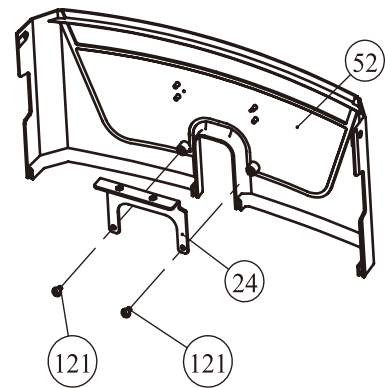
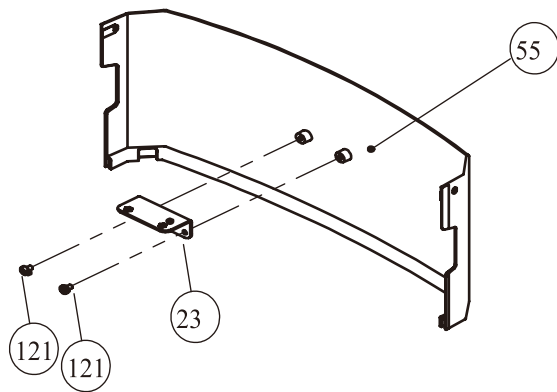

Assembly

STEP 2

1. Attach the Seated Frame ASSY (#2) and to the Weight Stack Frame ASSY (#1) using:
two M10*80 SHCS (#103) two M10 Nylon Lock Nut (#122)
four $\Phi 11*\Phi 20*2$ Flat Washer (#125)
2. Attach the Bottom Bracket ASSY (#25) to the Weight Stack Frame ASSY (#1) using:
two M8*20 SHCS (#118) two Flat Washer $\Phi 9*\Phi 16*1.6$ (#124)
3. Attach two Top Bracket (#26) to the Weight Stack Frame ASSY (#1) using:
two M8*70 BSHCS(#117) two M8 Nylon Lock Nut (#123)
four Flat Washer $\Phi 9*\Phi 16*1.6$ (#124)
4. Attach the Circular Foot Frame ASSY (#9) to the Seated Frame ASSY (#2) using:
two M10*65 SHCS (#112) two $\Phi 11*\Phi 20*2$ Flat Washer (#125)

Note: 1. Wrench Tighten Bolts and Nylon Lock Nuts.

2. Adjust the Adjustable Foot Plates to make the machines stable.

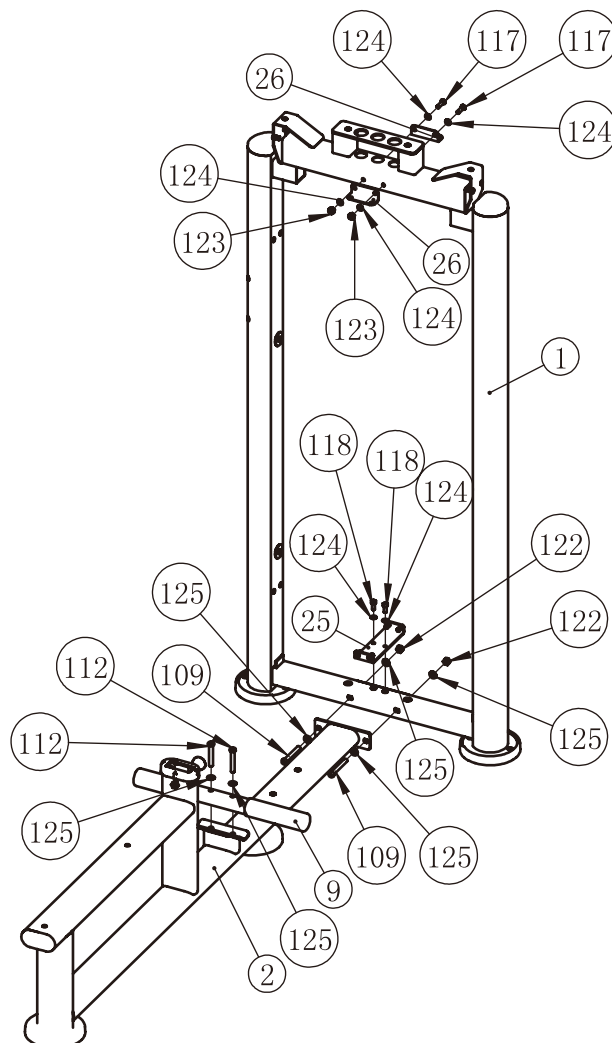

Assembly

STEP 3

Here is the assembly instruction for **160LBS Weights !**

1. Attach:

- two Guide Rod $\Phi 19 \times 1597$ (#44)
- two Weight Rubber Bumper (#19)
- two Weight Stack Space (#64)
- fifteen Weight Plate 10LBS (#63)
- one Top Plate (#42)

to the Weight Stack Frame ASSY (#1) using:

- two Guide Rod Fixing Sleeve $\Phi 25 \times \Phi 19 \times 45$ (#102)
- two Spring (#104)

2. Attach the Selector Pin W/Coil (#101) to the Top Plate (#42).

Grade No.	Part No.	Description	QTY
63	FE97193100	10LBS Weight Plate	15
64	FEWS01ASSY	Weight Stack Space	2

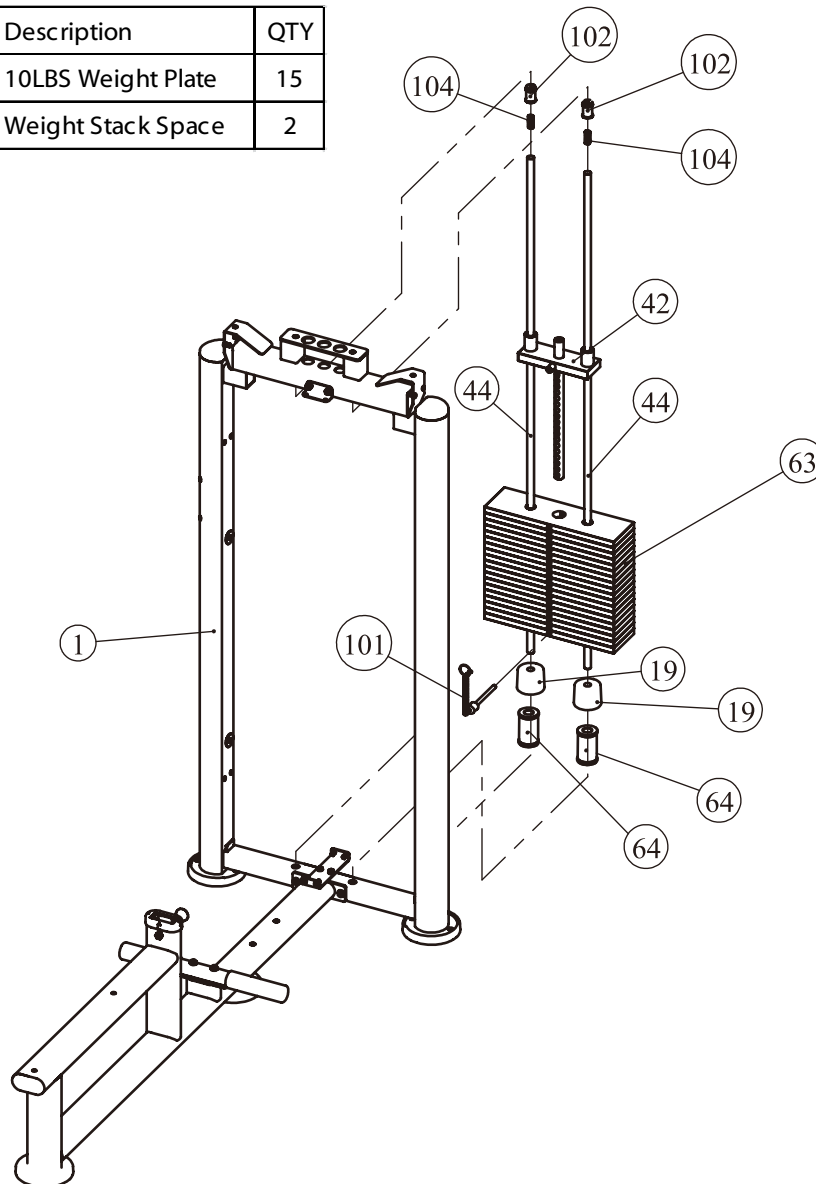

Assembly

STEP 3

Here is the assembly instruction for **200LBS Weights !**

1. Attach:

- two Guide Rod $\Phi 19 \times 1597$ (#44)
- two Weight Rubber Bumper (#19)
- nineteen Weight Plate 10LBS (#63)
- one Top Plate (#42)

to the Weight Stack Frame ASSY (#1) using:

- two Guide Rod Fixing Sleeve $\Phi 25 \times \Phi 19 \times 45$ (#102)
- two Spring (#104)

2. Attach the Selector Pin W/Coil (#101) to the Top Plate (#42).

Grade No.	Part No.	Description	QTY
63	FE97193100	10LBS Weight Plate	19

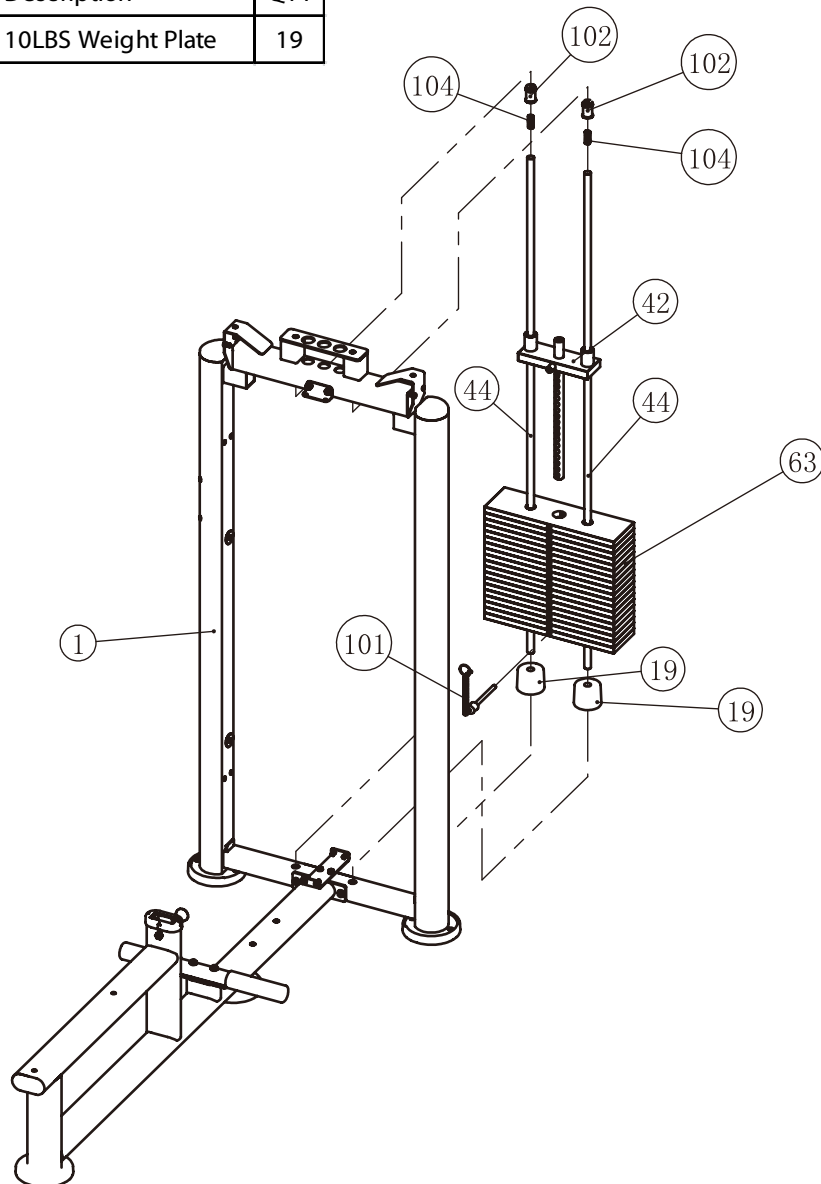

Assembly

STEP 3

Here is the assembly instruction for **235LBS Weights !**

1. Attach:

- two Guide Rod $\Phi 19 \times 1597$ (#44)
- two Weight Rubber Bumper (#19)
- two Weight Stack Space (#64)
- fifteen Weight Plate 15LBS (#63)
- one Top Plate (#42)

to the Weight Stack Frame ASSY (#1) using:

- two Guide Rod Fixing Sleeve $\Phi 25 \times \Phi 19 \times 45$ (#102)
- two Spring (#104)

2. Attach the Selector Pin W/Coil (#101) to the Top Plate (#42).

Grade No.	Part No.	Description	QTY
63	FE97193200	15LBS Weight Plate	15
64	FEWS01ASSY	Weight Stack Space	2

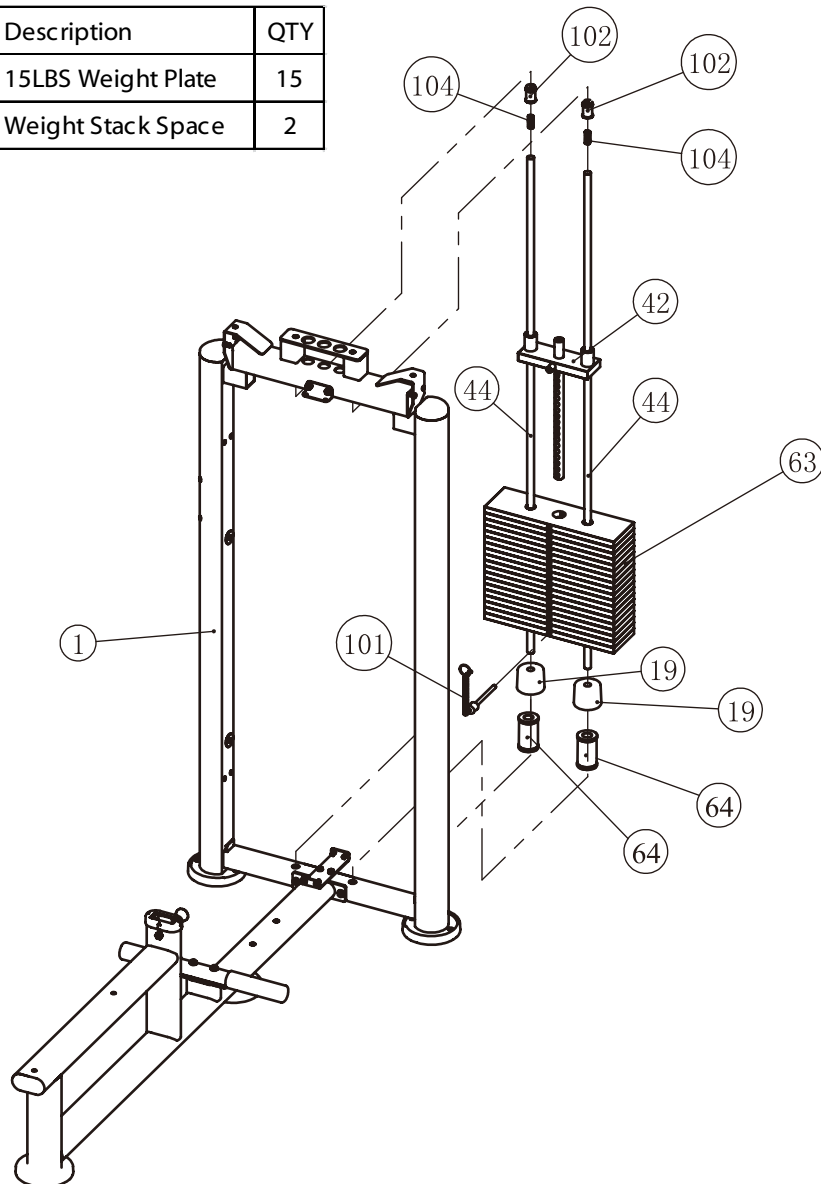

Assembly

STEP 3

Here is the assembly instruction for **295LBS Weights !**

1. Attach:

- two Guide Rod $\Phi 19 \times 1597$ (#44)
- two Weight Rubber Bumper (#19)
- nineteen Weight Plate 15LBS (#63)
- one Top Plate (#42)

to the Weight Stack Frame ASSY (#1) using:

- two Guide Rod Fixing Sleeve $\Phi 25 \times \Phi 19 \times 45$ (#102)
- two Spring (#104)

2. Attach the Selector Pin W/Coil (#101) to the Top Plate (#42).

Grade No.	Part No.	Description	QTY
63	FE97193200	15LBS Weight Plate	19

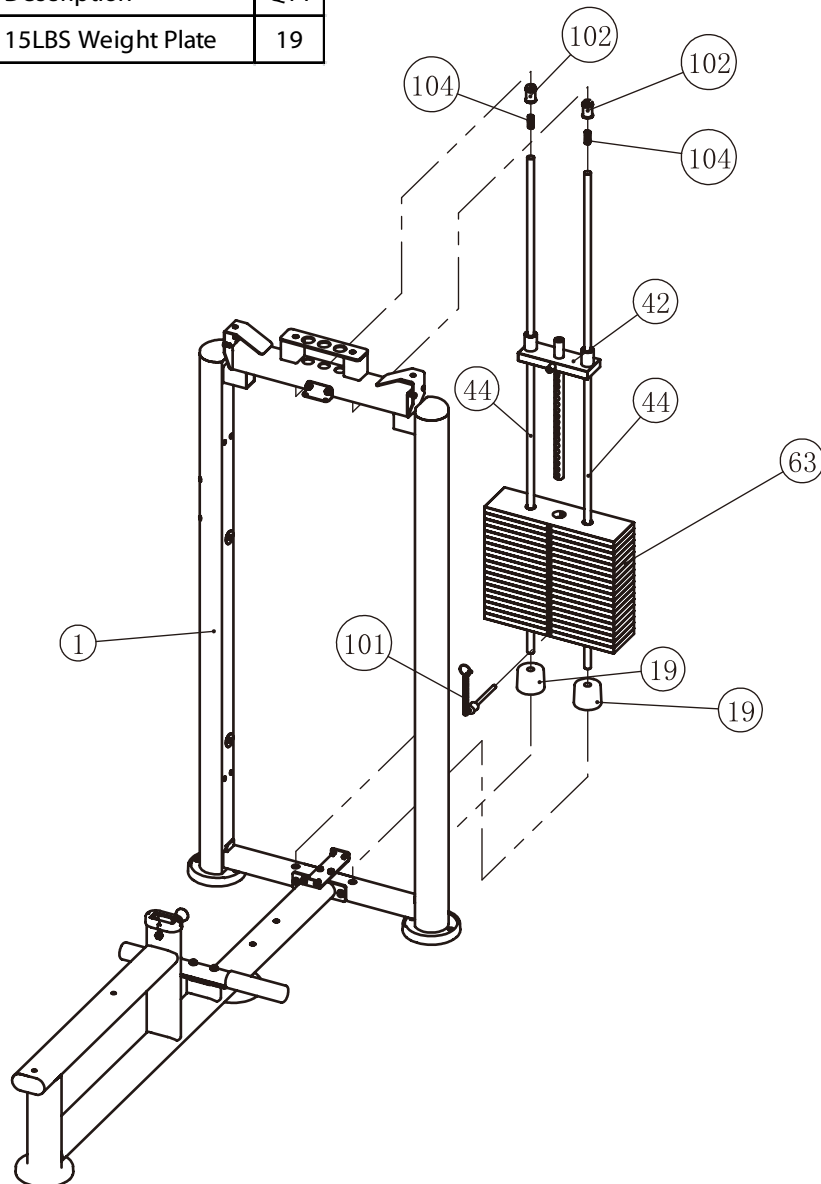

Assembly

All weight plate sticker paste schematic diagram

LBS 20	9
LBS 30	14
LBS 40	18
LBS 50	23
LBS 60	27
LBS 70	32
LBS 80	36
LBS 90	41
LBS 100	45
LBS 110	50
LBS 120	54
LBS 130	59
LBS 140	64
LBS 150	68
LBS 160	73
LBS 170	77
LBS 180	82
LBS 190	86
LBS 200	91
LBS 210	95
LBS 220	100
LBS 230	104

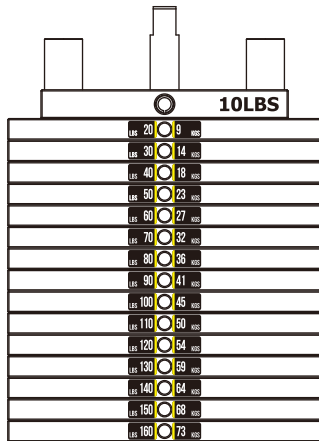

20-160LBS

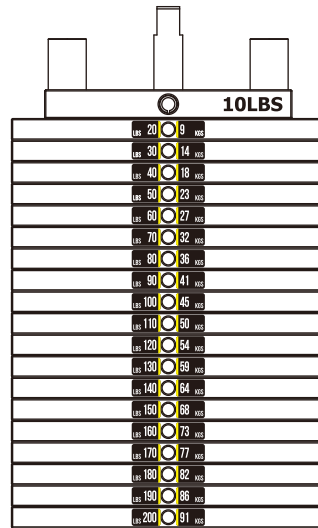

20-200LBS

LBS 25	11
LBS 40	18
LBS 55	25
LBS 70	32
LBS 85	38
LBS 100	45
LBS 115	52
LBS 130	59
LBS 145	66
LBS 160	72
LBS 175	79
LBS 190	86
LBS 205	93
LBS 220	100
LBS 235	107
LBS 250	113
LBS 265	120
LBS 280	127
LBS 295	134
LBS 310	141
LBS 325	147

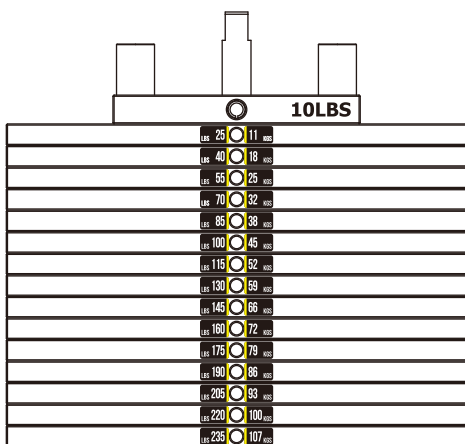

25-235LBS

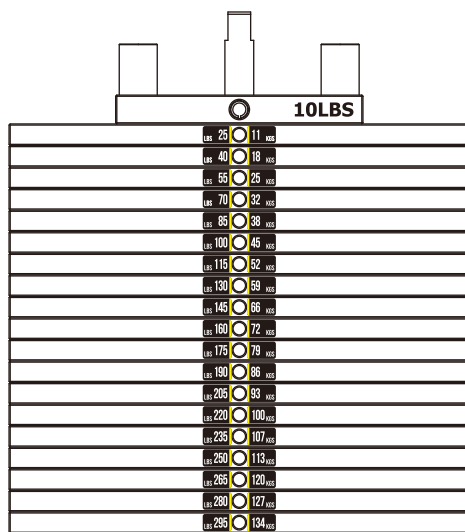

25-295LBS

Assembly

Step 4

Note: Must be attach the Lat Pull Cable (#12) to the Top Plate (#42), and pass through the middle hole of the Weight Stack Frame ASSY (#1).

1. Attach the Right Shroud (#61) and the Left Shroud (#62) to the Weight Stack Frame ASSY (#1) using:
four M6*20 CRPHS (#120)
2. Attach two Front Shroud (#53) to the Weight Stack Frame ASSY (#1) using:
two M6*20 CRPHS (#120)
3. Attach the Bottom Rear Shroud (#60) to the Weight Stack Frame ASSY (#1) using:
four M6*20 CRPHS (#120)
4. Attach the Rear Shroud (#56) to the Weight Stack Frame ASSY (#1) using:
two M6*20 CRPHS (#120)
5. Attach the Training Placard Cover (#52) to the Weight Stack Frame ASSY (#1) using:
four M6*20 CRPHS (#120)
6. Attach the Top Rear Shroud (#55) to the Weight Stack Frame ASSY (#1) using:
four M6*20 CRPHS (#120)
7. Attach the Top Cover (#51) to the Weight Stack Frame ASSY (#1) using:
two M6*20 CRPHS (#120) two Spout Plug $\Phi 16.5 \times 6.88$ (#103)

Note: Wrench tighten bolts.

Step 5

1. Attach the Handle Frame (#8) to the Support Frame (#6) using:
two M8*10 SHCS (#119) two Flat Washer $\Phi 9 \times \Phi 16 \times 1.6$ (#124)
2. Attach the Support Frame (#6) and the Front Frame ASSY (#3) to the Seated Frame ASSY (#2) using:
two M10*25 SHCS (#114) two M10*70 SHCS (#111)
two M10*15 HHB (#116) two M10 Nylon Lock Nut (#122)
two Spring Washer $\Phi 10$ (#115) eight $\Phi 11 \times \Phi 20 \times 2$ Flat Washer (#125)

Note: Not Wrench Tighten Bolts and Nylon Lock Nuts.

3. Attach the Top Frame ASSY (#5) to the Weight Stack Frame ASSY (#1) and the Front Frame ASSY (#3) using:
two M10*25 SHCS (#114) two M10*70 SHCS (#111)
two M10 Nylon Lock Nut (#122) two Spring Washer $\Phi 10$ (#115)
six $\Phi 11 \times \Phi 20 \times 2$ Flat Washer (#125)
4. Attach the FOAM Frame ASSY (#4) to the Seated Frame ASSY (#2) using:
one M10*25 SHCS (#114)

Note: Wrench Tighten Bolts and Nylon Lock Nuts.

Assembly

Step 4

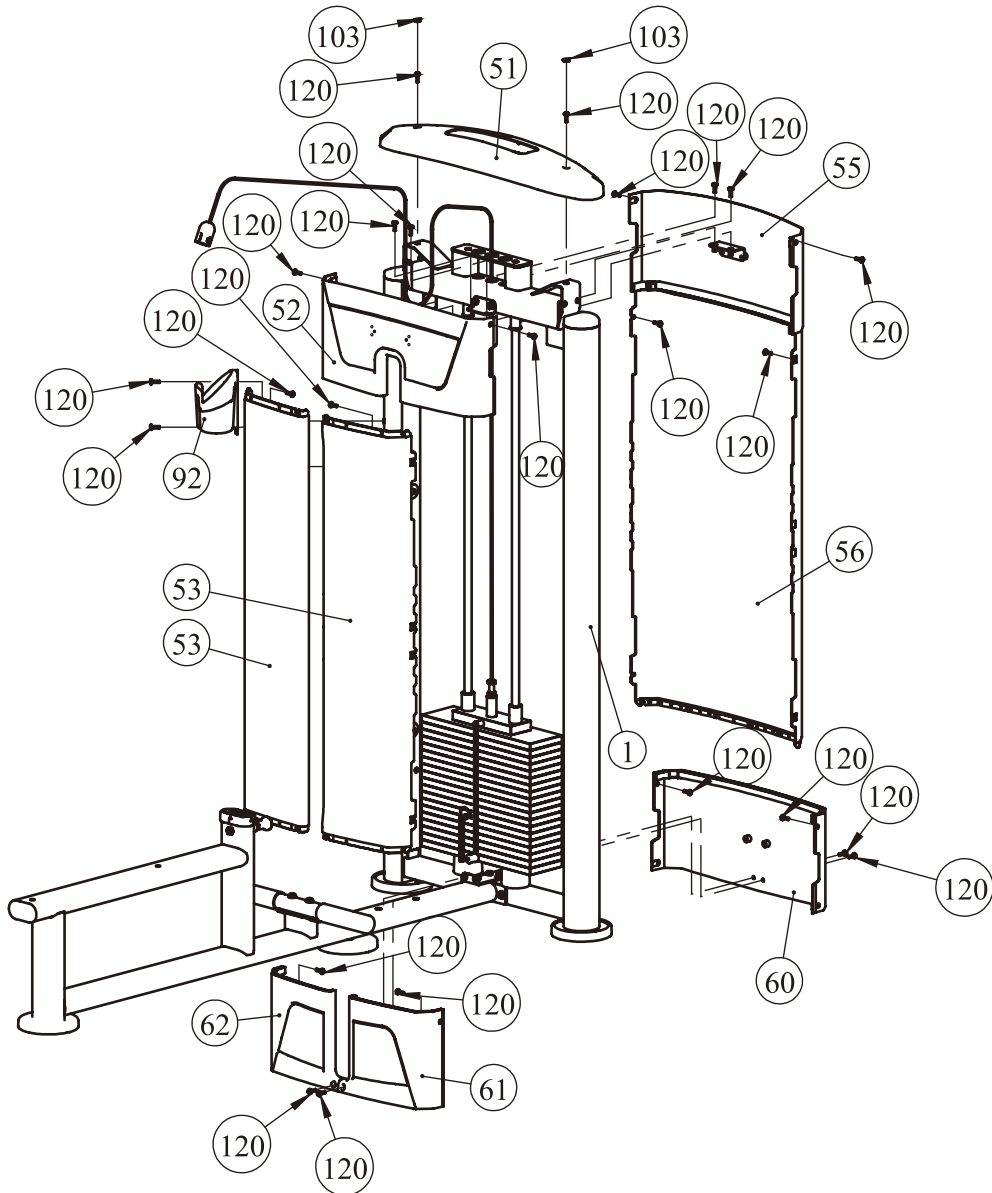

Assembly

STEP 6

NOTE: 1. Before attach the cable, you should Unlock the Bolt using Hex Key S=3/16" (#126).

2. Pay attention to the position.

1. Attach five 4.5" Pulleys (#15) and two U Bracket (#11) to the Top Frame ASSY (#5) using:
two M10*70 SHCS (#111)
three M10*65 SHCS (#112)
ten $\Phi 11*\Phi 20*2$ Flat Washer (#125)
five M10 Nylon Lock Nut (#122)
2. Attach two 4.5" Pulleys (#15) to the Pulley Bracket (#10) using:
two M10*50 SHCS (#113)
four $\Phi 11*\Phi 20*2$ Flat Washer (#125)
two M10 Nylon Lock Nut (#122)
3. Attach two 4.5" Pulleys (#15) and one 2" Pulley (#16) to the Front Frame ASSY (#3) using:
three M10*50 SHCS (#113)
six $\Phi 11*\Phi 20*2$ Flat Washer (#125)
three M10 Nylon Lock Nut (#122)
4. Attach one M10*50 SHCS (#113) and two $\Phi 11*\Phi 20*2$ Flat Washer (#125) and one M10 Nylon Lock Nut (#122) to the Front Frame ASSY (#3).
5. Attach the Lat Pull Cable (#12) to the Top Frame ASSY (#5) and U Bracket (#10).
6. Attach the Row Cable (#13) to the Front Frame ASSY (#3) and U Bracket (#10).

Note: Wrench tighten bolts and Nylon Lock Nuts.

Assembly

STEP 6

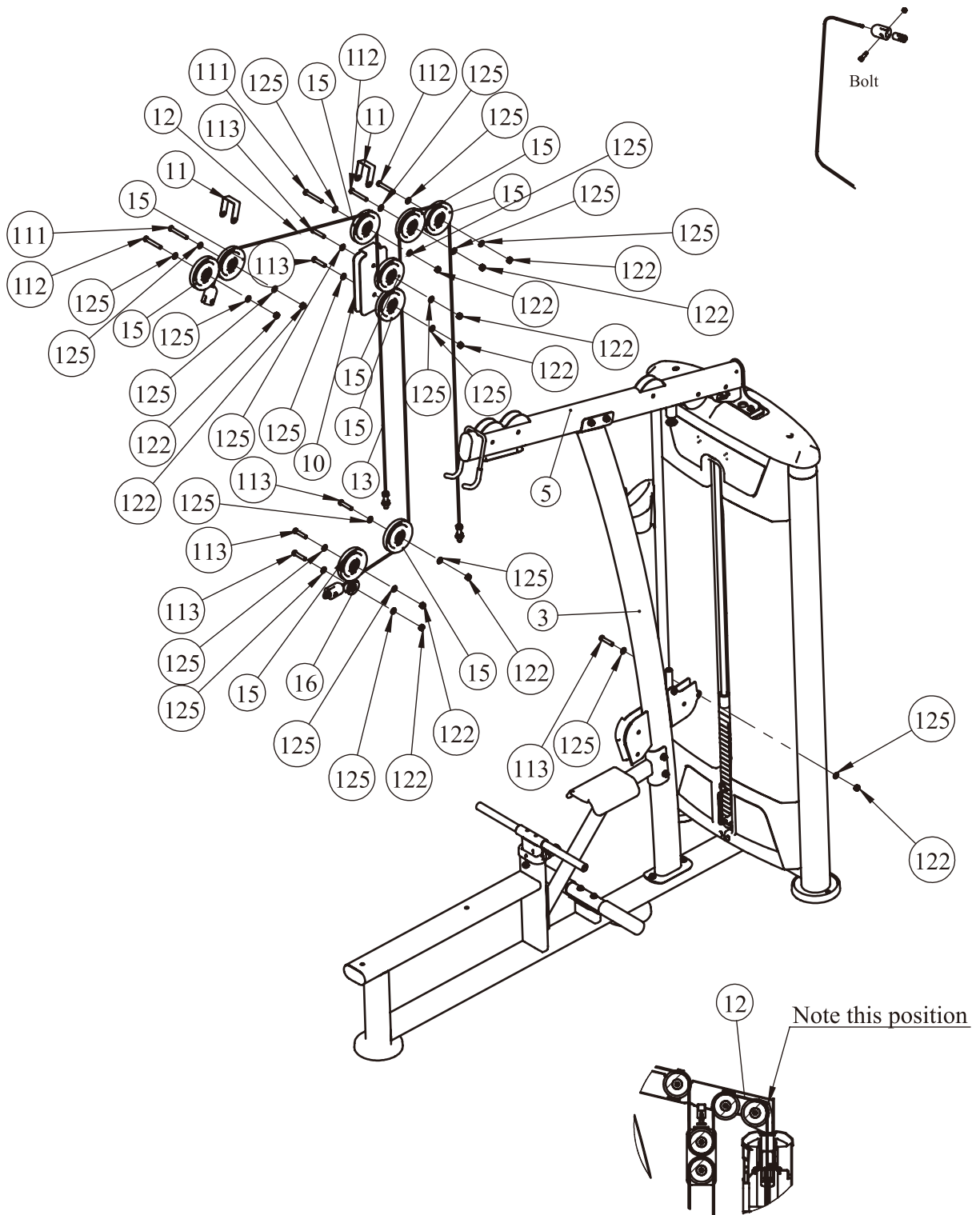

Assembly

STEP 7

1. Attach the Long Lat Bar (#17) to the Lat Pull Cable (#12) using:
one Gear Hook (#106) one Chain (#107)
2. Attach the Lat Bar ASSY (#18) to the Row Cable (#13) using:
one Gear Hook (#106)
3. Attach two FOAM ASSY (#77) to the FOAM Frame ASSY (#4) using:
two Plastic Ring (#108) two Cap ASSY (#105)
two M10*25 SHCS (#114)
4. Attach the Seat Pad (#76) to the Seated Frame ASSY (#2) using:
two M10*75 SHCS (#110) two $\Phi 11*\Phi 20*2$ Flat Washer (#125)

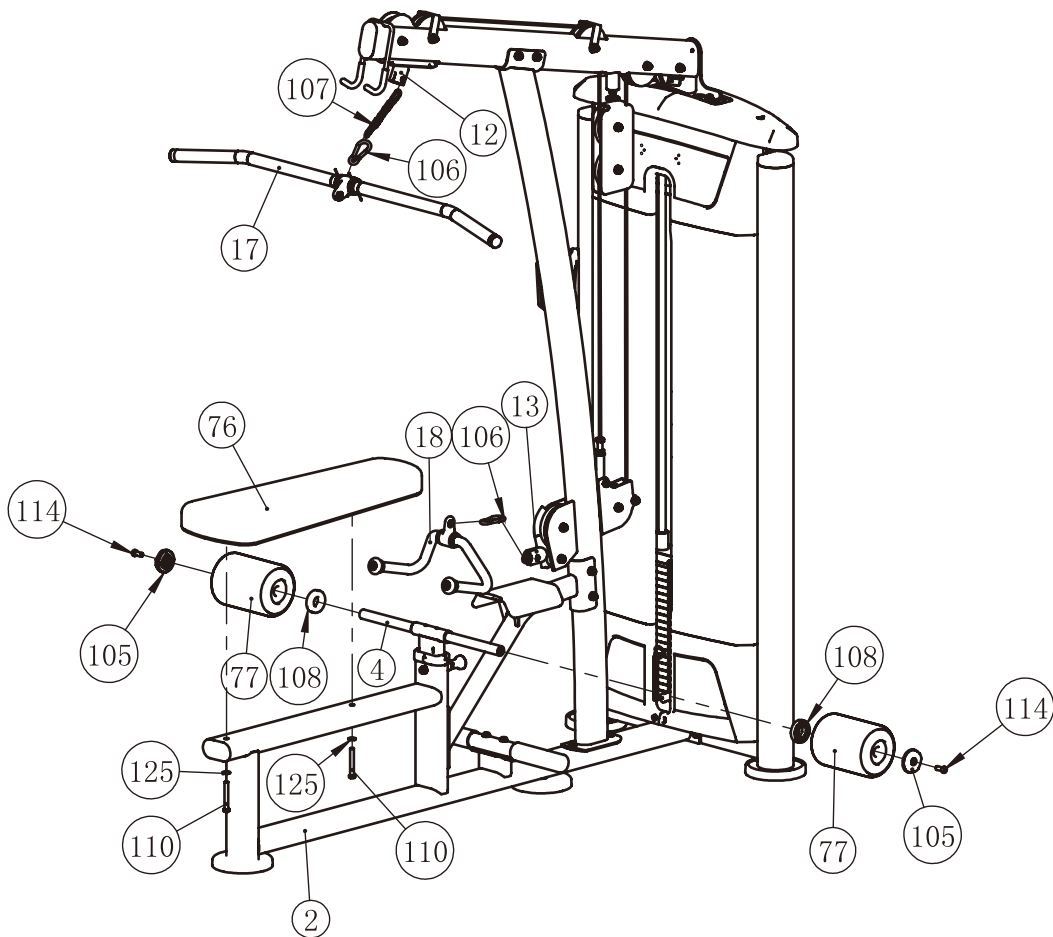

Adjust Instructions

Foam ASSY adjustment

1. Pull the Pin and adjust the Foam ASSY to the desired position.
2. Make sure the pin gets into the hole completely.

The use of Selector Pin W/Coil

1. Select an appropriate weight and put the Selector Pin W/Coil into the hole on it.
2. Make sure the Selector Pin W/Coil gets into the hole completely.

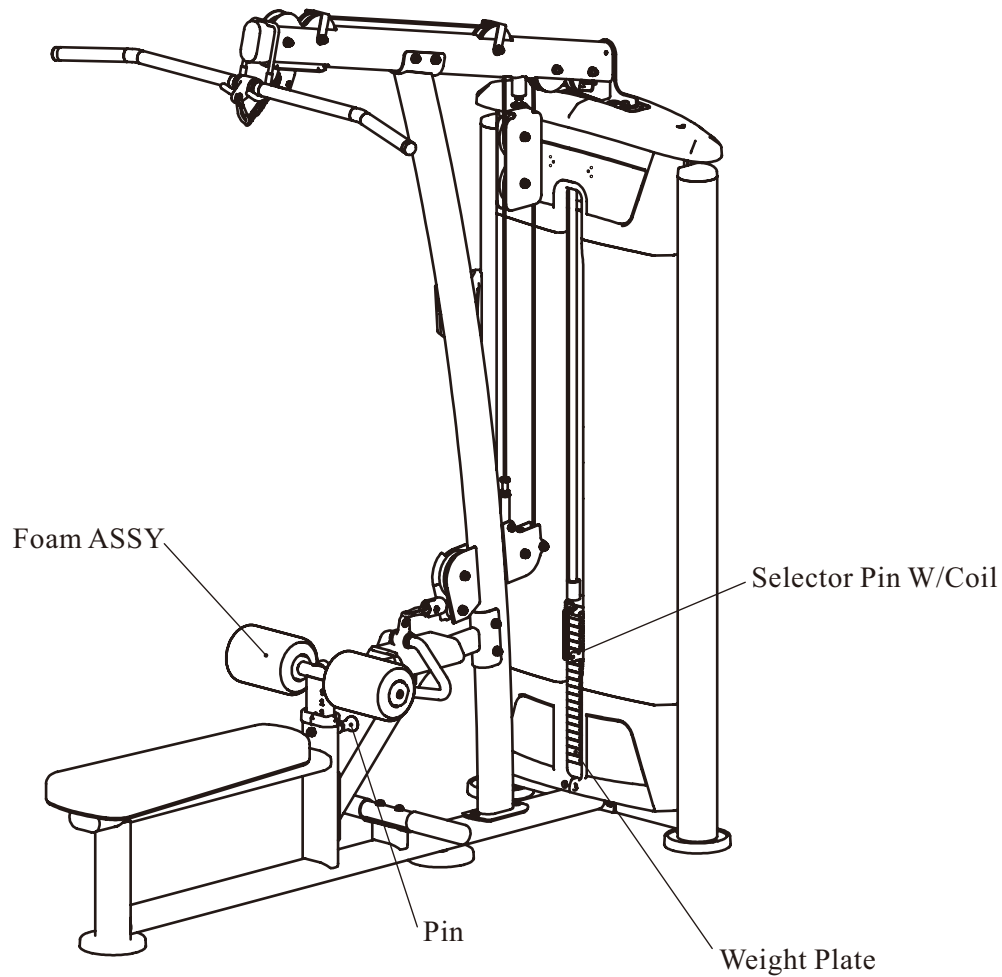

Exercise Instructions

LAT PULLDOWN/VERTICAL ROW

1. Select the appropriate weight.
2. Adjust roller to the desired position.
3. Latpulldown: Hold handles, pull down slowly toward your upper chest.
4. Slowly return to the starting position.

Row: Hold handles, move slowly back toward chest.

Lat pulldown Row

1. Select the appropriate weight.
2. Adjust roller to the desired position.
3. Latpulldown: Hold handles, pull down slowly toward your upper chest.
4. Slowly return to the starting position.

Row: Hold handles, move slowly back toward chest.- 4. Slowly return to the starting position.

Lat pulldown

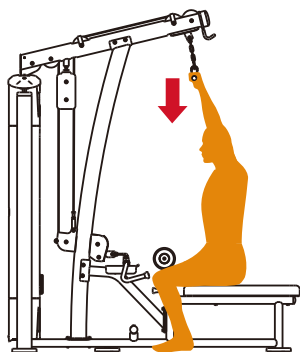

Row

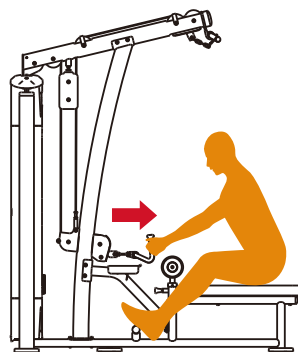

Maintenance Schedule

ROUTINE	COMMERCIAL MAINTENANCE	HOME MAINTENANCE	LATEST DATE ENTRY					
Inspect; Links, Pull Pins, Snap Locks, Swivels, Weight Stack Pins	DAILY	WEEKLY						
Clean; Upholstery	DAILY	WEEKLY						
Inspect; Cables or Belts and their tension	DAILY	WEEKLY						
Inspect; Accessory Bars, and Handles	WEEKLY	3 MONTHS						
Inspect; All Decals	WEEKLY	3 MONTHS						
Inspect; All Nuts and Bolts, Tighten if needed	WEEKLY	3 MONTHS						
Inspect; Anti-Skid Surface	WEEKLY	3 MONTHS						
Clean & Lubricate; Guide Rods with a Teflon (PTFE) based lubricant (Superlube)	MONTHLY	3 MONTHS						
Lubricate; Seat Sleeves, Turcite Bushings, Linear Bearing	MONTHLY	3 MONTHS						
Clean and Wax; All Glossy Finishes	6 MONTHS	YEARLY						
Repack with Grease; Linear Bearings	6 MONTHS	YEARLY						
Replace; Cables, Belts and Connecting Parts	YEARLY	3 YEARS						

Your equipment comes with a commercial maintenance decal. For personal, in home use, please follow the home maintenance schedule listed above.

General Maintenance Information

Links, Pull-Pins, Snap Hooks, Swivels, Weight Stack Pins:

- * Check all pieces for signs of visible wear or damage.
- * Check springs in snap hooks and pull-pins for proper tension and alignment.
- * If the spring sticks or has lost its rigidity, replace it immediately.

Upholstery:

- * To ensure prolonged upholstery life and proper hygiene, all upholstered pads should be wiped down with a damp cloth after every workout.
- * Periodically take the time to use a mild soap or an approved vinyl upholstery cleaner to deter the onset of cracking or drying. Avoid using any abrasive cleaners or cleaners not intended for use on vinyl.
- * Replace ripped or worn upholstery immediately.
- * Keep sharp or pointed objects clear of all upholstery.

Decals:

- * Inspect and familiarize yourself with any safety warnings or other user information posted on each decal.

Nuts and Bolts:

- * Inspect all nuts and bolts for any loosening and tighten if needed.
- * Go through a re-tightening sequence periodically to ensure that all hardware is tensioned proper.

Anti-Skid Surfaces:

- * These surfaces are designed to supply secure footing and need to be replaced if they appear worn or become slippery.

Belts and Cables:

- * We use only high quality belt, and mil-spec cables.
- * Visually inspect the belts and cables for fraying, cracking, peeling or discoloration.
- * While the machine is not in use, carefully run your fingers along the belt or cable to feel for thinning or bulging areas.
- * Replace belts and cables immediately at the first signs of damage or wear. Do not use equipment until belts or cables have been replaced.

Belt and Cable Tension:

- * Referring to the Owners Manual, when belts or cables are used check all bolt attachments to be sure they are properly attached.
- * Check slack in cables and re-adjust cable tension if needed.

Seat Sleeves, Guide Rods:

- * Wipe down adjusting tubes with a dust free rag before applying lubricant.
- * Lubricate seat sleeves and Guide Rods with a Silicon or Teflon based lubricant spray.

Linear Bearings:

- * Referring to the Owners Manual carefully disassemble the bearing from its housing and place a finger full of light grease (lithium, super lube, etc.) into the inside of the bearing. Using your finger, press the grease into the ball-bearings and their tracks. Repeat until the ball-bearing tracks are full of grease. Insert the shaft back into the bearing and wipe off excess grease.

PLEASE KEEP THIS FOR YOUR RECORDS

Weight Training Tips

Use this manual to guide you through the basic exercises you can perform on your equipment. To gain maximum results and avoid possible injury, consult a fitness professional to develop your complete exercise program.

Always consult your physician before starting any exercise program.

To be successful in your exercise program, it is important to develop an understanding of the basic principles of strength training. Now that you have your equipment, it is only natural that you want to get started immediately. First, determine a set of realistic goals and objectives for yourself. By deciding on an exercise plan that is right for you prior to starting, you will contribute significantly to your success.

Warm up properly before engaging in weight resistance training. Stretching, yoga, jogging, calisthenics or other cardiovascular exercise can help prepare your body for the heavier workload of lifting weights.

Learn how to perform the exercise correctly before using heavy weight. Correct form is important to avoid injury and to ensure that you work the proper muscle groups.

Know your limitations. If you are new to weight training or are embarking on an exercise regimen after a long layoff, start slowly and build foundational strength over a longer period of time.

Pay attention to your breathing. Exhale when you exert is a general rule of thumb. Never hold your breath.

