

**Single Rotor, Twin Rotor
and Four Rotor Rakes**



Andex Rotary Rakes



Andex Keeps Your Productivity Running





Quality forage starts with having the right equipment. When there is work to be done you need a rake that can get you there quickly, gets the job done efficiently and provides a clean and attractive swath. Providing speed and accuracy to prepare a clean crop with no dirt that will destroy the attractiveness of the feed is a key parameter. You want grass, not dirt in the swath.

High productivity has long been married to capacity, ease of use and durability. In addition you need the exact rake specification that suits your entire grass management setup. Your rake must be able to accurately feed the machine that follows, being it a forager, wagon or baler, altering to the changing crop intensity during the season.

Vicon offers a strong and competent product lineup, rugged and reliable Andex rakes with more of the things that you need to get the job done right. With an array of models and possibilities to suit your specific setup, the potential to boost your complete grass management with an Andex rake is there.

Helping You to Do More





Correctly adjusting and customizing the rake to the exact conditions facing you today is what adds the extra quality to your forage, ensuring that dirt stays out of the swath, yet leaving no crop behind. Setting the rotor height, adjusting the swath width and fine tuning the cam track (ProLine) is done easily and intuitively on all Andex rakes, taking the hassle out of the daily optimization.

The strong, yet flexible Vicon rake tines accurately moves the crop into the swath, and with a wire diameter of up to 10mm they additionally provide the necessary capacity to move even large volumes of crop. The curved tine arms, a true Vicon hallmark, engineered to ensure that the tine arms will leave the swath at exactly the right time, promotes better and more accurate swath formation.

Durability Exemplified

CompactLine

The Andex CompactLine rakes features oil-immersed cam discs, guide rollers and tine bearings, alleviating maintenance on these components. Strong tine arms and bearings in an oilbath, ensure longevity and easy maintenance. The oil level of the gearbox is easily controlled from the outside.

High-tensile tine arm holders and two bearings on either side of the driveshaft, provide the compact unit with strength and dependability. Vicon-developed cam tracks are specifically tailored to individual rotor diameters, for optimum raking at any working width and on any model.

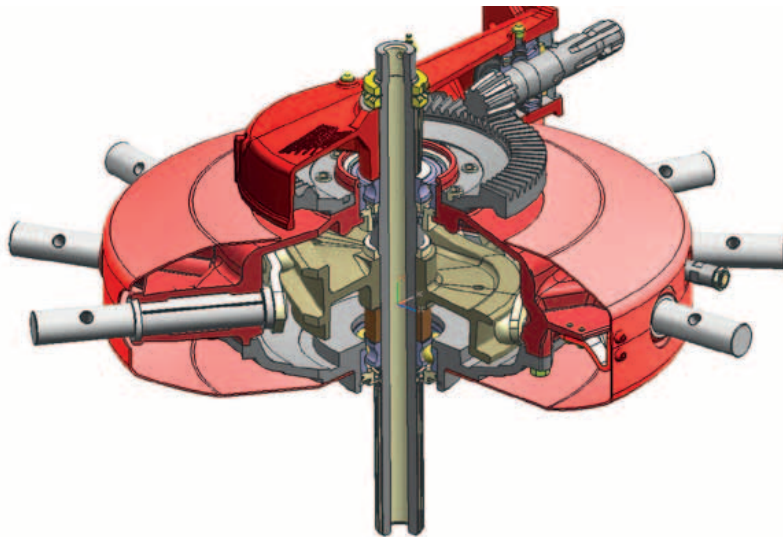

Steplessly adjustable cam track for easy adaptation to different amounts and sorts of crop.



Injection moulded aluminium tine arm support housings provide strength and reduced weight.



Pinion gear with two bearings separate from the main driveline, keeping pinion and crown wheel securely in place.

ProLine

The Andex ProLine rakes feature a unique drive system, which comprises oil-immersed pinion and crown wheels. The fully enclosed design ensures full and permanent lubrication, and makes the entire system absolutely maintenance-free.

Our extensive experience guarantees well-proven technology of the highest standard. The hardened cam track is adjustable and with an extremely large 400mm diameter, giving positive guidance to the steel rotors and quiet machine running.

The optimised shape of the curve disc allows the tine arms to exit the crop faster, leaving a more uniform swath formation. Aluminium bearing housings, with two integral ball bearings and wide support, provide solid and maintenance-free tine arm mounting. Additionally all tine arms including housing are removed by simply removing 3 bolts. Fast and easy!



ProLine 10mm diameter tines.



Each tine arm can be dismantled and repaired individually.

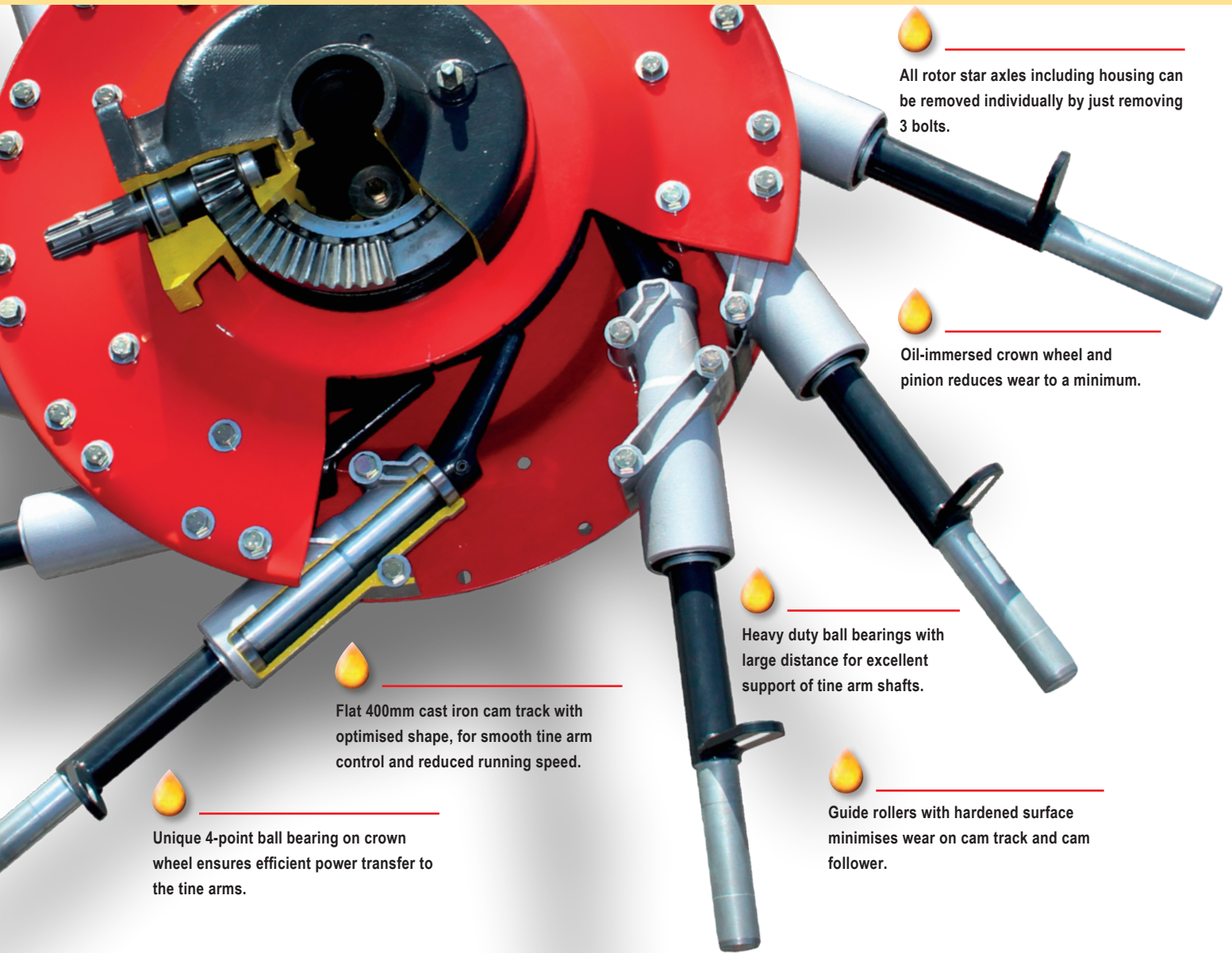

All rotor star axles including housing can be removed individually by just removing 3 bolts.

Oil-immersed crown wheel and pinion reduces wear to a minimum.

Heavy duty ball bearings with large distance for excellent support of tine arm shafts.

Flat 400mm cast iron cam track with optimised shape, for smooth tine arm control and reduced running speed.

Unique 4-point ball bearing on crown wheel ensures efficient power transfer to the tine arms.

Guide rollers with hardened surface minimises wear on cam track and cam follower.

Curved Tine Arms Supports Regular and Even Swaths

All Andex rakes are fitted with curved tine arms, to ensure a regular and even swath formation. Additionally the curved shape prevents material from being pushed in the direction of the rotor.

The specially angled tine arms ensure a higher lift out of the swath and leave the swath at just the exact right time in order to prepare regular and even swaths.

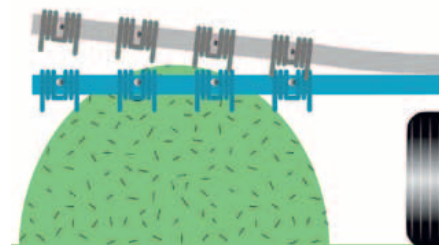

Stay on Track with TerraLink Quattro

Three-Dimensional Adaptation

What really matters is the quality of the silage and hay, which you produce. Precision in every part of the raking process is paramount to ensure that none of the valuable material is left behind, while at the same time securing a clean and attractive crop without dirt.

The TerraLink Quattro system has become a true legend related to accurate ground following, vital to avoid dirt in the swath - especially in uneven field conditions.

It is a rather simple, yet unique system providing excellent 3-dimensional adaptation to ground contours. And it is absolutely maintenance- and wear-free.

The Strength is in the Arm

The openly constructed frame arm absorbs vibrations away from the rotor and allows torsion flexibility, adding the extra tracking flexibility and stability of the rotor. Each rotor operates in 3 dimensions to accurately respond and adjust to uneven field conditions.

High Stability

The trailed wheel axle configuration, where weight is centered on the front boogie wheels, enhances quiet running and prevents lifting and tine bouncing. Each wheel is positioned as close as possible to the raking tines to ensure highest possible rotor stability, inviting for higher travel speed.

How TerraLink Quattro Adapts in 3 Dimensions



The rotors are fully flexible in all directions, which means the tines have an exceptional ground following ability....

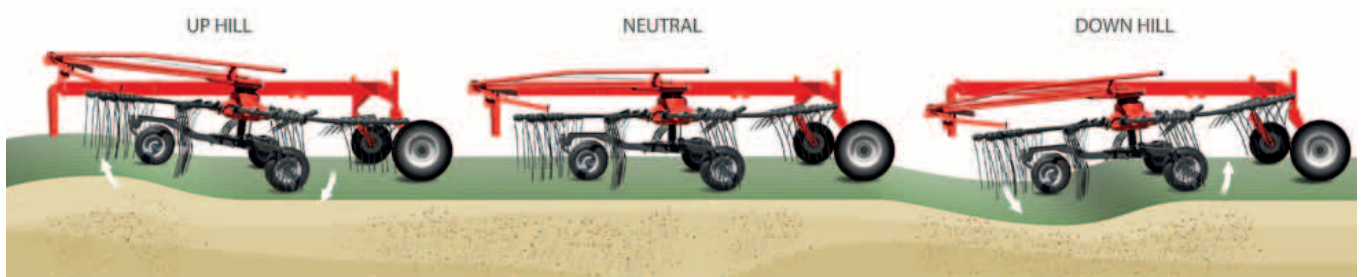

... ensuring a clean raking result without dirt in the crop.

TerraLink Quattro for Accurate Tracking

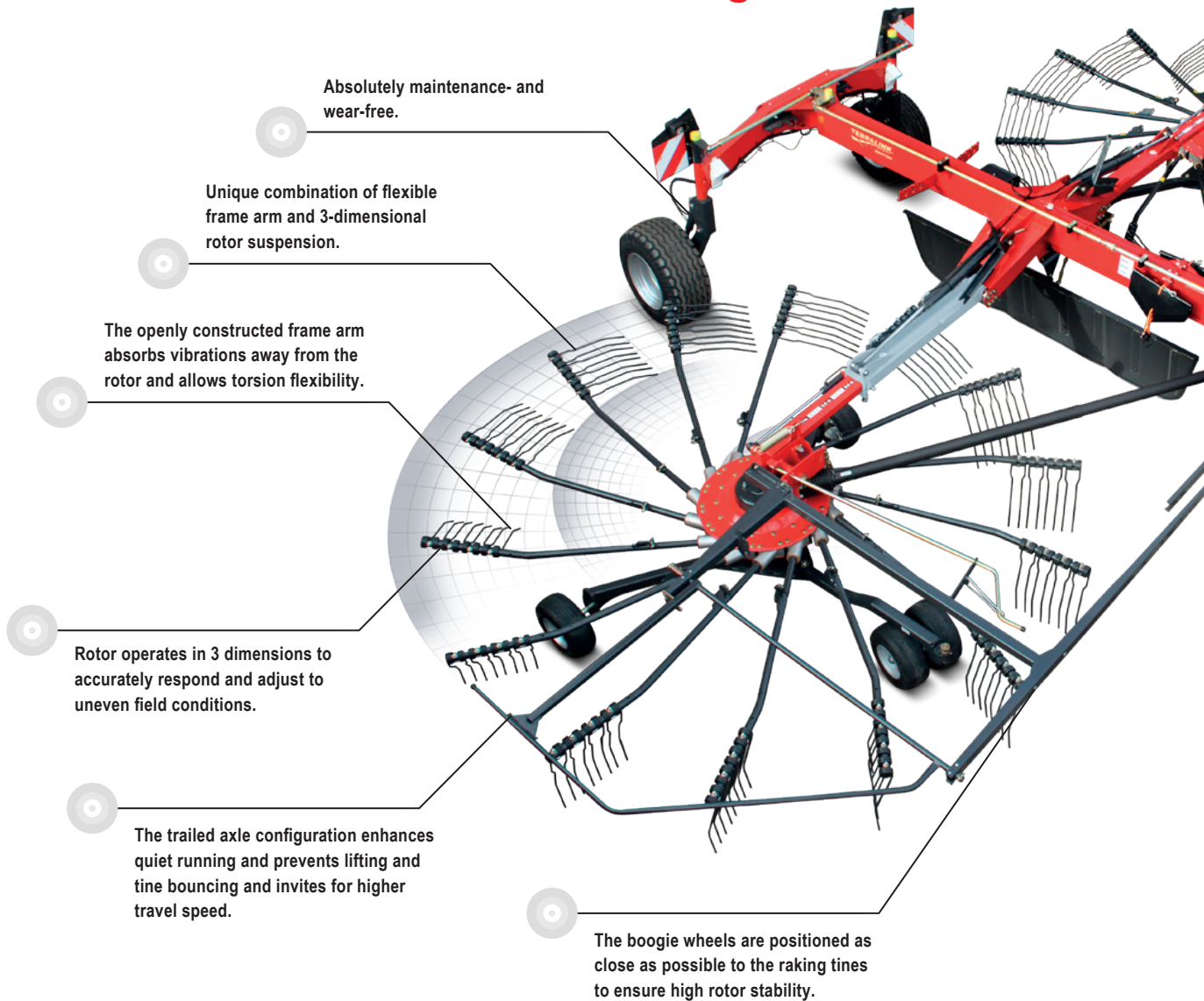

The Real TerraLink Quattro Advantage

The TerraLink system consists of two parts. First the lifting arm and second the undercarrier. The arm is slotted on the downside. This, together with special steel quality, makes it possible for the frame to flex without breaking.



Andex 1505 • ProLine

No Compromise with 15m Working Width



15.00m Working Width

The Andex 1505 with 15.00m working width is designed for high output and heavy use. It is fitted with a total of 56 tine arms and 254 tines. Four rotors, each fitted with 13/15 tine arms and 4/5 tines per arm.

Brakes and Tyres

The tyre size of (560/45 R22.5) not only ensures gentle treatment of the ground, but also makes for excellent stability both in the field and on the road. Hydraulic or pneumatic brakes permit road speeds up to 50km/h, so it takes minimum time to move the machine from one field to another.

Optimal Ground Pressure at all Times

Hydraulic ground pressure control means constant and adjustable pressure on the rotors regardless of their position on the carrier frame. Free mobility in three planes combined with 360° steered twin wheels per rotor give each rake head perfect ground following ability for the cleanest possible raking performance.



Each rotor can be independently set for height using the hydraulic system.



The 2-pt headstock allows a turning angle up to 80°.

A Superbly Manoeuvrable Unit

The 2-pt headstock allows a turning angle up to 80° and the steered wheel axles ensure these Vicon rakes have unequalled manoeuvrability. Despite a total length of 9.20m, even narrow gateways or approach lanes to fields are easily negotiated.

The front rotors can be lifted separately or each side can be lifted pairwise, convenient for raking crop away from fence lines or when rake low crop fields. For transport the Andex 1505 will fold into a transport height below 4.00m, and a transport width of 3.00m.



The hydraulic suspension supports protecting the ground under all conditions. Three working modes of the suspension can be chosen.



Front and rear rotors can be lifted with adjustable time delay between front and rear, pairwise or individual.



High lift of rotors ensures generous clearance during headlands turns. Clearance height can be adjusted infinitely.

Andex 1505 • ProLine

Customize the Size of Your Swath!



Adjustable Working Width

Raking width can be continuously varied on the move between 9.80m and 15.00m. Raking width can be matched to the density of crop to obtain an evenly shaped and equally wide swath over the full length. You can independently steer an outside rotor around an obstacle such as a pole or tree without having to change travel direction with the complete machine.



The two outer rotors can be adjusted individually to match a working width between 9.80-15.00m.



Hydraulic adjustment of swath width.



TERRALINK
QUATTRO



Everything Under Control with ISOBUS Technology

The An dex 1505 is fully ISOBUS 11783 compliant. This means that it will plug directly into an ISOBUS compatible tractor without the need for a separate terminal.

The An dex 1505 is available with the IsoMatch Tellus or the new IsoMatch Tellus GO control terminals.

The new IsoMatch Tellus GO is especially developed for controlling machines in a simple way. Just connect your machine, step into the tractor cab, switch on the power button and GO. The terminal brings the implement automatically into view.

Take Full Control

The following functions can be operated with the IsoMatch Tellus terminal:

- Swath and working width indication in meters.
- Programmable lifting height of rotors.
- Automatic selection of transport or working position by pressing an icon.
- Separate lifting of all four rotors.
- Independent setting of rotor height.
- Independent adjustment of working width, left and right hand side.
- Active and selectable hydraulic suspension on front rotors.
- Steering of transport axle.
- Optional with joystick.



The optional active steering wheel provides excellent manoeuvrability during narrow gateways and tight corners.



With its' clever folding mechanism the total height remains below 4.00m - despite a rotor diameter of 3.85m. And there is no need to remove tine arms for road transport.

Andex 1254 • CompactLine

Master Productivity and Accuracy



Boost Your Capacity

The Andex 1254 is targeted to make lighter work of tough and demanding operations. Being able to accurately feed the machine that follows and keep up efficiency of the complete harvesting system is an essential part of the raking job.

With its impressive capacity of 12.50m working width, straightforward design and the possibility to adjust both work and swath width, the Andex 1254 is designed to boost the complete process of collection and pick-up, altering to the changing crop intensity during the season.

Easy Handling – More Productivity

The Andex 1254 is designed with uncomplicated work days in mind. Forget about sophisticated sensors and control functions, the Andex 1254 is designed around the operator with simplicity in mind, focusing on the elements that adds real value. Take the control unit for instance.

It comes with a rather handy design including pre-selected functions for an array of easy operations. Only one double acting and one single acting spool valve are required to run the Andex 1254.

Excellent Swath Formation

The rear rotors of Andex 1254 are designed with a smaller diameter than the front rotors and also turn at higher speed to ensure a more accurate swath formation. This, in combination with the curved tine arms, provides accurate and evenly shaped swaths.

The maintenance-free TerraLink Quattro rotor suspension system, operating in 3 dimensions for excellent tracking, works in close combination with the 4 wheeled rotor to ensure high accuracy and stability on slopes. And it is absolutely maintenance- and wear-free.



More Uptime with 4m Transport Height

The An dex 1254 gives no reasons for wasting time, not even when moving between fields. Just rise the rotors and off you go, safe below 4.00m transport height – no need to leave the tractor for removing tines arms. Large transport wheels and hydraulic brakes are standard.

For storage all tines arms are detachable to allow a storage height as low as 3.40m. A strong and stable storage foot ensures fast and trouble-free coupling and uncoupling.



TerraLink Quattro is a unique combination of flexible frame arm and 3-dimensional rotor suspension.



Easy and intuitive control function, all handled from the tractor cab.



Strong and stable parking foot for easy coupling and uncoupling.

Andex 1254 • CompactLine

Easy Handling – More Productivity



Hydraulic Adjustment of Working and Swath Width

The hydraulic adjustment of working and swath width allows you to customize swath intensity and width to the capacity of the following machine.

All conveniently handled and controlled from the tractor seat. Working width can be set between 10-12.50m and swath width can be adjusted between 1.20-2.20m, adding the necessary flexibility.



Working width can be set hydraulically between 10-12.50m.



Setting the delay between lifting/lowering the front and rear rotors is infinitely adjustable.

Easy Headland Management

The An dex 1254 comes with enhanced headland management. In addition to high ground clearance of rotors during headland turns, it is possible to tailor time delay between lifting/lowering the front and rear rotors to driving speed and field conditions. This is done mechanically in an easy and uncomplicated way.

The An dex 1254 will do sharp turns of up to 80°, both on headlands and during transport when passing narrow gate ways.

The rotors can as a standard feature lift pairwise, convenient for raking crop away from fence lines or when raking low crop fields.



Swath width is also set hydraulically between 1.20-2.20m.



The An dex 1254 will do sharp turns up to 80°.



High lift of rotors ensures generous clearance during headland turns.

Andex 1104 • ProLine

High Flexibility and Performance



The Andex 1104, with up to 11.00m working width, designed for heavy duty operation and maximum performance.

11m Working Power

Andex 1104 - for the high performance segment, normally covered by more expensive four rotor rakes. Easy operation, excellent manoeuvrability and a heavy duty design characterize this machine. Despite a working width of 11.00m, the rake is very compact and manoeuvrable in the field.

TerraLink Quattro

The Andex 1104 is fitted with the TerraLink Quattro system, offering perfect ground followings. A unique combination of an undercarriage with 6 wheels and a special designed rotor suspension, ensures a superb raking performance, even at high forward speed and with big rotor diameter.



Standard equipment on the Andex 1104 includes the maintenance-free TerraLink Quattro system, for superb ground following.

TERRALINK

QUATTRO

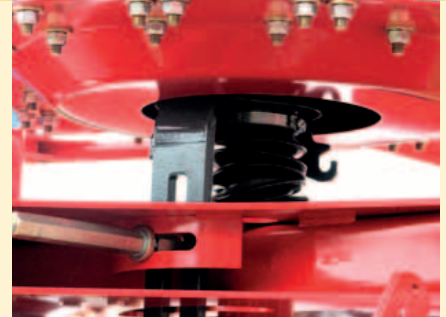

Adjustable Rotor Height

Double acting hydraulic height adjustment of the rotors to suit the length of stubble or ground conditions, along with hydraulic suspension to reduce ground pressure.



Adjustable Working Width

Hydraulically adjustable working width to be set between 9.20m and 11.00m.

Easy Operation

The new Andex 1104 is designed for easy operation, with a number of features, making the working day as comfortable as possible.

15 Tine Arms per Rotor

With 15 double tangential tine arms and 4 double tines per arm, the Andex 1104 is well equipped for maximum raking performance. The high tine frequency ensures clean raking performance, even at reduced rpm and high forward speed.



Active wheel steering, allowing sharp turns on headlands and during transport.



To reach a transport height below 4.00m, the tine arms can be removed and placed safely on the carrier frame.



The Andex 1104 is equipped with an operator's box which includes all hydraulic functions of the machines. All functions can be pre-selected and then executed by operating the valve on the tractor. Even the transport lock is operated hydraulically.

Andex 804-844-904 Hydro • ProLine

The Heavy Duty Centre Swath Rakes



Durable Performance

With adjustable working widths of 7.00m to 9.00m respectively these heavy duty specification rakes provide the swath formation capability to keep harvesting operations running at their optimum output. At the heart of all models is a heavy duty ProLine rotor head system. Proven to perform year in, year out in heavy first cut crops, they are superbly engineered, with the crown wheel and pinion assembly running in a fully enclosed oilbath.

Flexible Working Width

Andex 804: 7.00-8.00m working width.
Andex 844: 7.60-8.40m working width.
Andex 904 Hydro: 8.00-9.00m working width.



Hydraulic adjustment of working width.



Excellent Maneuverability

The rear carrier frame with controlled steering facility gives this rake excellent track following characteristics, allowing tight turns on headlands and loss free swathing even in awkwardly shaped fields. Even if the rotors are lifted on a steep slope, the steering system reliably counteracts any deviation. During headland turns the rotors are lifted up to 45cm from the ground to prevent swath damage.



- Actively steered wheels for excellent tracking.
- Ability to make sharp turns up to 80°.
- High lift of up to 45cm of rotors ensures generous clearance during headlands turns.
- Raking with only one rotor (standard on Andex 904 Hydro, optional on Andex 804 and 844).



Easy setting of correct raking height.



Andex 844 with 8.40m working width, fully enclosed gearbox and hydraulic adjustable working width.

Andex 804-844-904 Hydro • ProLine

More Uptime with Clever Transport Solutions



Andex 804 - Design Optimized for Transport

The Andex 804 masters both extensive working width and compact transport measures. The new design of the wheel axles allows for the addition of generous 380/55 wheels as standard, whilst still offering a transport width as narrow as 2.80m, making it the perfect match for narrow roads and tight gateways.

Transport height is below 4.00m, even with all tine arms attached. No need to leave the tractor, just fold and go. Add in the 80° turning headstock and active wheel steering, and you have a highly manoeuvrable machine on road and in the field.



The Andex 804 includes a transport height below 4.00m without leaving the tractor cab and actively steered axles supporting tight turns on headlands and during transport.



With 9.00m working width and transport height below 4.00m, even without detaching tine arms...



... the new Andex 904 Hydro offers remarkable productivity with no downtime.



Standard running wheels of Andex 804 is extra wide 380/55 flotation tyres for excellent ground protection.

Andex 904 Hydro - High Capacity in Field, Compact on the Road

The Andex 904 Hydro will go as wide as 9.00m during work with its' twin rotors, and offers the flexibility to adjust the working width between 8-9.00m. It will stay below 4.00m during transport, even with all tine arms fully mounted.

Thanks to the hydro axles, which are a unique Viccon feature, the complete rake can be lowered hydraulically for transport, ensuring that it will go below 4.00m transport height. Another benefit is that the gravity point is moved towards the ground, and in combination with the wide track width and large 380/55-17 tyres it creates excellent weight distribution and stability during transport.

Andex 724-724 Hydro-764 • CompactLine

Compact Design – High Performance



Andex 724 and 764 double rotor rakes are designed with durability in mind.

Centre Swath Rakes

Vicon offers three cost-effective double rotor rakes with strong design. The rakes produce a nice even centre swath from raking widths of between 6.20m and 7.80m. They are mounted on a strong and stable frame to ensure long lifetime. Features such as actively steered wheels, the TerraLink Quattro system and hydraulically working width adjustment are standard.

Unique Manoeuvrability

The rear carrier frame with controlled steering facility allows tight turns on headlands and loss free swathing even in awkwardly shaped fields. When in headland position, the rakes show an outstanding lifting height of 40cm, preventing swath damage. The ability to make sharp turns up to 80° and the cross stabilizer in the headstock are unique Vicon features.



A spring ensures parallel lowering and lifting of the rotors and prevents tines from digging into the ground during headland operation.



Vicon centre swath rakes are converted hydraulically for transport from the tractor cab.



To limit transport height further the tine arms can be removed on the Andex 764. The swath board is folding up automatically.



The Andex multirotor rakes are fitted with TerraLink Quattro for excellent raking.

Andex 724 Hydro - Resetting the Standard

The new Andex 724 Hydro is fitted hydraulically operated axles on the main frame, in order to lift and lower the machine during transport and operation. This feature significantly reduces transport height by 40cm, allowing a transport height as low as 3.45m.

Add in features such as adjustable working width of 6.20-7.30m, TerraLink Quattro ground contour following and heavy duty carrier frame design, and the result is low maintenance, higher productivity and maximum operation comfort.



All main functions, such as lifting and lowering of mainframe and rotors are operated from the tractor cab, using an electro hydraulic control terminal.

It is also possible to pre-select lift activation of the rotor units via the terminal. Such an integrated solution is offered only by Vicon.

Andex 724 and 764

Both new Andex double rotor rakes offer hydraulically adjustable working width. This enables varying the swath width from 1.20-2.10m, ensuring a perfect match to the pick-up width of loader wagons, balers and foragers.



The hydraulic adjustable rotors can be set between 7.00m...



...and 7.80m working width.

Andex 694 VARIO-694 EVO • CompactLine

Compact Effectiveness



The Andex 694 Side Delivery Rake

Completing the CompactLine of side delivery rakes, this compact and nimble rake features a sturdy frame and the well-proven TerraLink Quattro ground following system. In addition the VARIO model offers the possibility of raking two separate swaths.

With a working width of 6.90m, the machine rakes up double swaths of up to 13.20m.

There are 11 removable tine arms equipped with 4 tines on the front and 12 arms with 5 tines on the rear rotor in order to compensate for the higher load going through the second rotor.

A host of exciting details such as the well thought-out continuous driveline make Andex 694 a universal machine that suits a wide range of applications.

Trailing boogie wheels made for tight cornering, without the risk of tilting the rotors and tines scraping the ground. The two rotors provide generous overlapping and the cam tracks are matched to each other to transfer the material uniformly.

Andex 694 like all Vicon frame-based rakes, features a headstock that turns through a 80° angle to give superb tracking and superior manoeuvrability.

Andex 774 • ProLine

Side Delivery Rakes



The low position of the rear frame, moves the gravity point close to the ground for excellent stability.



Active wheel steering for improved manoeuvrability in combination with large wheels for reduced compaction.



The side delivery concept allows you to collect crop from 15.00m into a single swath.

Double Up on Efficiency

The new Andex 774 double rotor rake delivers a working width of 7.70m. The side delivery concept adds excellent flexibility in swath formation and allows you to collect crop from a working width of up to 15.00m into one swath. The high build mainframe concept offers excellent ground clearance in headland position (40cm). Actively steered wheels allow sharp turning, both on headlands and during transport when passing narrow gate ways.

Andex 774 is fitted with the renowned Vicon ProLine gearbox, with its' maintenance-free oilbath solution. The shape of the Vicon hallmark, the massive 400mm curve disc, allows the tine arms to leave the crop faster, leaving a more uniform swath shape. In addition the rotors have been upgraded to 12 tine arms on the front rotor, each with 4 tines, and 13 tine arms, each with 5 tines on the rear rotor. This ensures more accurate raking performance and allowing higher forward speed.

The carrier frame features a lower position of the rear frame, moving the gravity point closer to the ground for improved stability. The rotor wheels of the undercarriage are positioned further to the back of the rotor for improved ground contour following under difficult circumstances. In addition Andex 774 is fitted with the Vicon TerraLink Quattro wheel system for superb ground contour followings. This system controls the rotor in 3 dimensions.

Andex 714T VARIO-714T EVO • CompactLine

The Flexible Raking Solution



Flexible Raking

The Andex 714T VARIO and 714T EVO are designed for maximum flexibility for raking in different conditions. The twin rotors, working independently from each other, makes it possible to collect either one large swath or two smaller swaths.

Alternatively the rakes can place two large swaths into one, allowing a total of up to 12.50m crop to be gathered into one.

Vicon SideShift

The VARIO version also offers the patented SideShift system as an option, which comprises electro-hydraulic control of all functions. SideShift offers the possibility to side shift both rotors - both front and the rear - from the tractor cab. With this patented system, raking along field boundaries or around trees is no problem - as the tractor can run at a safe distance from the obstacles. It is also possible to drive with the tractor on already raked ground.



With 50cm lifting height, swaths can be driven over with no problem at all. Rotors are lifted using only a single acting valve.



TERRALINK

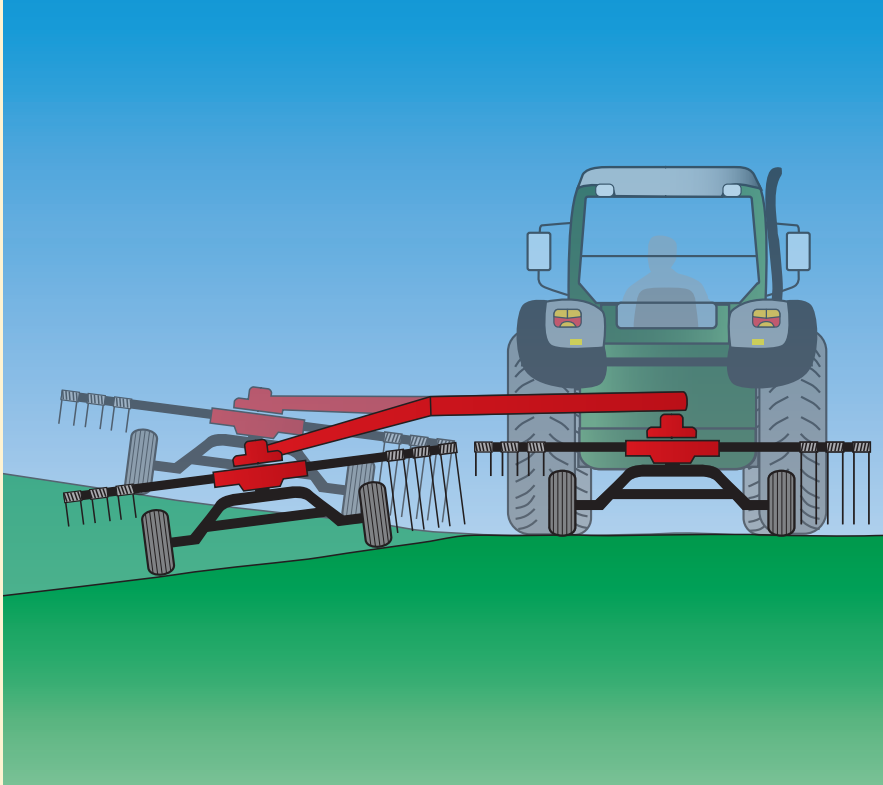

The 714T VARIO with 7.10m working width and unique new SideShift device.



SideShift to the right - conveniently passing trees.



SideShift to the left - raking without driving on unranked crop.

Vicon TerraLink

Completely maintenance- and wear-free:

- Quiet machine running due to automatic damping.
- Wide track boogies with large wheels provide perfect ground contour following.

- Trailed axle configuration enhances quiet running and reduces tractor input power.
- Superb tracking in road transport.

Easy Conversion from Working to Transport Configuration

There is no need to remove tine arms: moving the Andex 714T VARIO and 714T EVO to transport position only requires a simple operation on the control unit. The swath deflector is lifted hydraulically and transport width for Andex 714T VARIO and 714T EVO is only 3.00m (to reach 2.45m, the tine arms can be removed).



Both rakes are capable of placing small narrow swaths for hay crops.



Andex 714T EVO/VARIO in transport.

Andex 424-464 • ProLine

Built-In Reliability



Andex 464 ProLine single rotor rake with 4.60m working width.

High Performance

Vicon's ProLine single rotor rakes offer a gearbox design with excellent working result. Features such as oscillation dampers, tandem axles and HydroLift height adjustment are hallmarks of the single rotor rakes.

ProLine Gearbox

The Andex single rotor rakes are based on the ProLine gearbox technology. These machines offer working widths of 4.20m and 4.60m respectively and are fitted with the renowned Vicon ProLine gearbox, with its maintenance-free oilbath solution.

The ProLine gearbox offers better swath formation. Compare to others in the market existing solutions. The shape of the Vicon hallmark, the massive 400mm curve disc, has been improved to allow the tine arms to leave the crop faster, leaving a more uniform swath shape.

Both rakes are standard fitted with both 4 wheel tandem axles and oscillation dampers, offering excellent ground contour following, minimizing the amount of dirt collected in the swath.

HydroLift Concept

A unique Vicon feature of the Andex 424 and 464 is the standard HydroLift concept. It is a hydraulic height adjustment system that allows the driver to quickly adjust working height to different ground conditions from the tractor cab.



For transport or storage, the rotor guard frames are folded up close to the mainframe, locking automatically into position. An assistor spring linked to the swath board reduces the effort required.



Oscillation dampers ensure excellent running characteristics.



As an option these rakes can be supplied with a third wheel, to ensure even better flotation.



Tine arms can be easily removed.

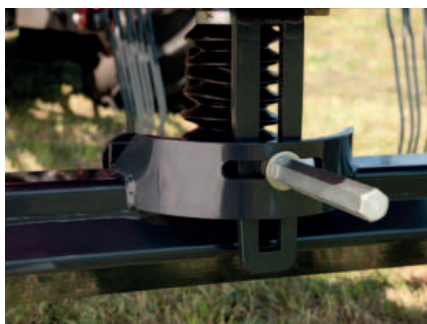

Infinitely variable cam track adjustment allows fine tuning, to obtain optimum raking and swath formation according to crop conditions.

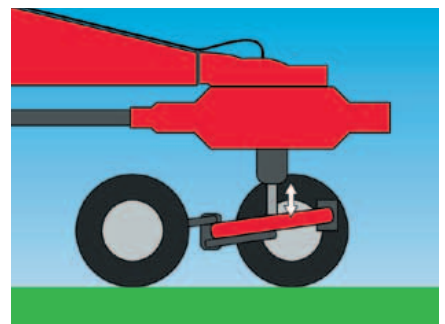

HydroLift height adjustment also offers the possibility to set a minimum height.

Andex 323-353-394-424T-434-474T • CompactLine

Compact Design, Low Maintenance



Andex 434 with
4.30m working width.

The Compact Range

For smaller raking operations, Vicon offers several models designed for use on lower horsepower tractors, whilst delivering similar raking performance compared to its' higher specification machines. With the pivoting three point linkage machines and also a trailed version, there is a model to suit any need, from lowland farmers, to the users working on steep hillsides.

Andex 'Compact' Rotor Head

The rotor head is grease lubricated. Within a fully enclosed housing, the maintenance-free cam track and cam followers are running permanently lubricated in an oilbath. The rotor shaft and pinion shaft are all mounted on two bearings for maximum strength and long service life.

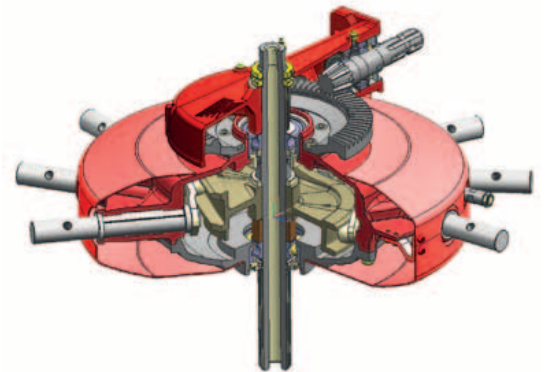

Compact design for easy maintenance.



The An dex 353 with 3.50m working width offers high performance with a simple, but reliable system.



All rakes can be set for reduced transport and storage width by removing the tine arms and placing them on the carrier frame.



A pivoting 3-pt headstock ensures perfect ground following performance, and perfect tracking when cornering. Oscillation dampers are optionally available.



An dex 474T – 4.70m working width and a weight of only 665kg.



With a linkage mounted drawbar, the An dex 474T can be easily operated by low horse power tractors.



The machine can conveniently be raised up to a height of 50cm from the tractor driver's seat.

Curved Tine Arms

All An dex CompactLine rakes feature cranked tine arms for significantly cleaner raking performance and optimised swath formation. This design ensures that the row of tines on each tine bar has a more effective approach angle to the oncoming crop, and also gives a cleaner lift out of the tine from the formed swath.

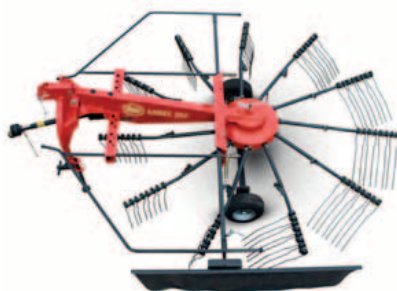

The An dex 394 with 3.90m working width for fast and effective raking action.



As an option these rakes can be supplied with a third wheel, to ensure even better flotation.

Technical Specifications

Andex	323	353	394	424	424T	434	464	474T	694 VARIO	694 EVO
Dimensions/weights										
Working width (m)	3.20	3.50	3.90	4.20	4.20	4.30	4.60	4.70	6.90/7.70	6.90
Working width (ft)	(10'6")	(11'6")	(12'10")	(13'9")	(13'9")	(14'1")	(15'1")	(15'5")	(22'8"/22'12")	(22'8")
Transport width (m)	1.60	1.75	1.75	1.75	2.00	2.00	2.15	2.40	2.80	2.80
Transport width (ft)	(5'3")	(5'9")	(5'9")	(5'9")	(6'7")	(6'7")	(7'1")	(7'10")	(9'2")	(9'2")
Transport length (m)	3.10	3.35	3.60	3.95	4.00	3.85	4.25	4.75	8.45	8.45
Transport length (ft)	(10'2")	(10'12")	(11'10")	(12'12")	(13'1")	(12'8")	(13'11")	(15'7")	(27'9")	(27'9")
Parking height (m)	1.60	1.70	1.85	2.60	2.30	2.00	2.75	2.65	3.45/4.10	3.45/4.10
Parking height (ft)	(5'3")	(5'7")	(6'1")	(8'6")	(7'7")	(6'7")	(9'0")	(8'8")	(11'3"/13'5")	(11'3"/13'5")
Weight (kg)	320	420	460	640	570	498	695	665	1935	1745
Weight (lb)	(705)	(926)	(1014)	(1410)	(1256)	(1098)	(1532)	(1466)	(4266)	(3847)
Swath width (m)										
Swath width (ft)										
Capacity theo. (ha/h)	3.5	3.9	4.3	4.6	4.6	4.7	5.1	5.1	7.6	7.6
Hitching system										
Pivoting 3-pt headstock (cat.)	1/2	1/2	1/2	2	-	1/2	2	-	-	-
Lower links (2-pt.)	-	-	-	-	-	-	-	-	•	•
Linkage drawbar	-	-	-	-	•	-	-	•	-	-
Gauge wheel 16°	o	o	o	o	o	o	o	o	-	-
Rotors/Tine arms/Tines										
Rotor diameter (m)	2.60	2.80	3.05	3.35	3.35	3.35	3.65	3.65	3.35	3.35
Rotor diameter (ft)	(8'6")	(9'2")	(10'0")	(10'12")	(10'12")	(10'12")	(11'12")	(11'12")	(10'12")	(10'12")
Swath delivery	left	left	left	left	left	left	left	left	left	left
Number of rotors	1	1	1	1	1	1	1	1	2	2
Number of arms per rotor	9	10	11	12	11	12	13	12	11/12	11/12
Number of double tines/arm	3	4	4	4	4	4	4	4	4/5	4/5
Tine diameter (mm)	9	9	9	10	9	9	10	9	9	9
Continuous cam track	-	-	-	•	-	-	•	•	-	-
Detachable tine arms	•	•	•	•	•	•	•	•	•	•
Height adjustment	rack trail	mech.	mech.	hydr.	mech.	mech.	hydr.	mech.	mech.	mech.
Wheels and axles										
Tyre (rotors)	15x6.00-6	16x6.50-6	16x6.50-6	16x6.50-6	16x6.50-6	16x6.50-6	16x6.50-6	18x8.50-8	16x6.50-6	16x6.50-6
Fixed tandem axle	o	o	o	•	•	o	•	•	-	-
Pivoting tandem axle	-	-	-	-	-	-	o	o	-	-
Stand. tyres (carrying frame)	-	-	-	-	-	-	-	-	10.0/75-15.3	10.0/75-15.3
Opt. tyres (carrying frame)	-	-	-	-	-	-	-	-	-	-
Optional equipment										
Carrier arm compensating	o	o	o	-	-	o	•	•	-	-
Locking catch for slopes	o	o	o	•	-	o	•	•	-	-
Safety accessories										
Warning panels	o	o	o	o	o	o	o	o	•	•
Road lights	o	o	o	o	o	o	o	o	•	•

• = standard o = optional - = not available * = double swath

714T VARIO	714T EVO	724	724 Hydro	764	774	804	844	904 Hydro	1104	1254	1505
6.60/7.10*	6.60/7.10	6.20-7.30	6.20-7.30	7.00/7.80	7.35	7.00-8.00	7.60-8.40	8.00-9.00	9.20-11.00	10.00-12.50	9.80-15.00
(21'8"23'4")	(21'8"23'4")	(20'4"/23'11")	(20'4"/23'11")	(23'/25'7")	(24'1")	(22'12"-26'30")	(24'11"-27'7")	(26'3"-29'6")	(30'2"-36'1")	(32'10"-41")	(32'2"-49'3")
3.00	3.00	2.80	2.80	2.80	2.98	2.80	2.98	2.98	2.98	2.90	3.00
(9'10")	(9'10")	(9'2")	(9'2")	(9'2")	(9'9")	(9'2")	(9'9")	(9'9")	(9'9")	(9'6")	(9'10")
7.55**	7.55**	5.90	6.05	5.90	8.95	5.95	6.25	6.25	7.40	8.75	9.20
(24'9")	(24'9")	(19'4")	(19'10")	(19'4")	(29'4")	(19'52")	(20'6")	(20'6")	(23'3")	(28'71")	(30'2")
-	-	3.90	3.45**	3.45**/4.10	3.70**/4.35	3.90	3.45**/4.10	3.35**/3.99	3.85**/5.00	4.00	3.45**/4.00
-	-	(12'10")	(11'4")	(11'4"/13'5")	(10'6"/14'3")	(12'10")	(11'4"/13'5")	(10'11"/13'1")	(12'8"/16'5")	(13'1")	(11'4"/13'1")
1400	1350	1640	1640	1640	2290	2065	1950	2310	2865	4250	5700
(3086)	(2976)	(3615)	(3615)	(3615)	(5049)	(4553)	(4300)	(5092)	(6316)	(9370)	(12566)
		1.20-2.00	1.20-2.00	1.30-2.10		1.40-2.20	1.40-2.20	1.20-2.20	1.40-3.10	1.20-2.20	
		(3'11"-6'7")	(3'11"-6'7")	(4'3"-6'11")		(4'7"-7'3")	(4'7"-7'3")	(3'11"-7'3")	(4'7"-10'2")	(3'11"-7'3")	
7.3	7.3	7.5	7.5	8.4	8.1	8.8	9.2	9.9	12.1	13.75	16.5
-	-	-	-	-	-	2	-	-	-	-	-
-	-	•	•	•	•	-	•	•	•	•	•
•	•	-	-	-	-	-	-	-	-	-	-
•	o	-	-	-	-	o	-	-	-	-	-
2.95	2.95	3.00	3.00	3.35	3.65	3.35	3.65	3.85	4.55	3.35	3.85
(9'8")	(9'8")	(9'10")	(9'10")	(10'12")	(11'12")	(10'12")	(11'12")	(12'8")	(14'11")	(10'12")	(12'8")
left	left	centre	centre	centre	left	centre	centre	centre	centre	centre	centre
2	2	2	2	2	2	2	2	2	2	4	4
11/12	11/12	11	11	11	12/13	2x12	2x12	2x14	2x15	2x12	13/15
4	4	4	4	4	4/5	4	4	4	4	4	4/5
9	9	9	9	9	10	10	10	10	10	10	10
-	-	-	-	-	•	•	•	•	•	•	•
•	•	-	-	•	•	•	•	•	•	•	•
hydr./mech.	hydr./mech.	mech.	mech.	mech.	mech.	mech.	mech.	mech.	hydr.	mech.	hydr.
18.5x8.50-8	18.5x8.50-8	16x6.50-6	16x6.50-6	16x6.50-6	16x6.50-6	16x6.50-6	16x6.50-6	16x6.50-6	16x6.50-6	16x6.50-6	16x6.50-6
- / o	- / o	o	o	o	-	o	o	o	•	o	Terra
-	-	-	-	-	-	-	-	-	-	-	Contact
-	-	10.0/75-15.3	10.0/75-15.3	10.0/75-15.3	380/55-17	10.0/75-15.3	380/55-17	380/55-17	380/55-17	10.0/75-15.3	550/45x22.5
-	-	-	-	-	-	-	-	-	-	-	•
-	-	-	-	-	-	-	-	-	-	-	-
-	-	-	-	-	-	-	-	-	-	-	-
•	•	•	•	•	•	•	•	•	•	•	•
•	•	•	•	•	•	•	•	•	•	•	•

Information provided in this brochure is made for general information purposes only and for worldwide circulation. Inaccuracies, errors or omissions may occur and the information may thus not constitute basis for any legal claim against Kverneland Group. Availability of models, specifications and optional equipment may differ from country to country. Please consult your local dealer. Kverneland Group reserves the right at any time to make changes to the design or specifications shown or described, to add or remove features, without any notice or obligations. Safety devices may have been removed from the machines for illustration purposes only, in order to better present functions of the machines. To avoid risk of injury, safety devices must never be removed. If removal of safety devices is necessary, e.g. for maintenance purpose, please contact proper assistance or supervision of a technical assistant. © Kverneland Group Kerteminde AS



Kverneland Group

Kverneland Group is a leading international company developing, producing and distributing agricultural machinery and services.

Strong focus on innovation allows us to provide a unique and broad product range with high quality. Kverneland Group offers an extensive package aimed at the professional farming community, covering the areas of soil preparation, seeding, forage and bale equipment, spreading, spraying and electronic solutions for agricultural tractors and machinery.

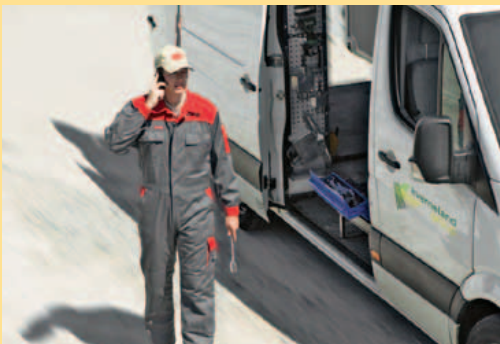

Original Spare Parts

Kverneland Group spare parts are designed to give reliable, safe and optimal machinery performance - whilst ensuring a low cost life-cycle. High quality standards are achieved by using innovative production methods and patented processes in all our production sites.

Kverneland Group has a very professional network of partners to support you with service, technical knowledge and genuine parts. To assist our partners, we provide high quality spare parts and an efficient spare parts distribution worldwide.

 **Watch us on YouTube**
www.youtube.com/kvernelandgrp

 **Like us on facebook**
www.facebook.com/KvernelandGroup
www.facebook.com/iMFarming

 **Follow us on Twitter**
[@KvernelandGroup](https://twitter.com/KvernelandGroup)
[@iM_Farming](https://twitter.com/iM_Farming)

Kverneland Group UK Ltd.
 Walkers Lane, Lea Green, St. Helens
 Merseyside, WA9 4AF
 Phone + 44 1744 8532 00

Kverneland Group Ireland Ltd.
 Hebron Industrial Estate
 Kilkenny, Ireland
 Phone + 353 56 51597

www.vicon.eu

