

PONDMASTER®

CLEARGUARD

PRESSURIZED POND FILTER

CARE AND OPERATING INSTRUCTIONS

MODELS	ITEM #		
	No UV	With UV	
		120V	230V
2700	05610	05615	05617
5500	05620	05625	05627
8000	05630	05635	05637
16000	05640	05645	

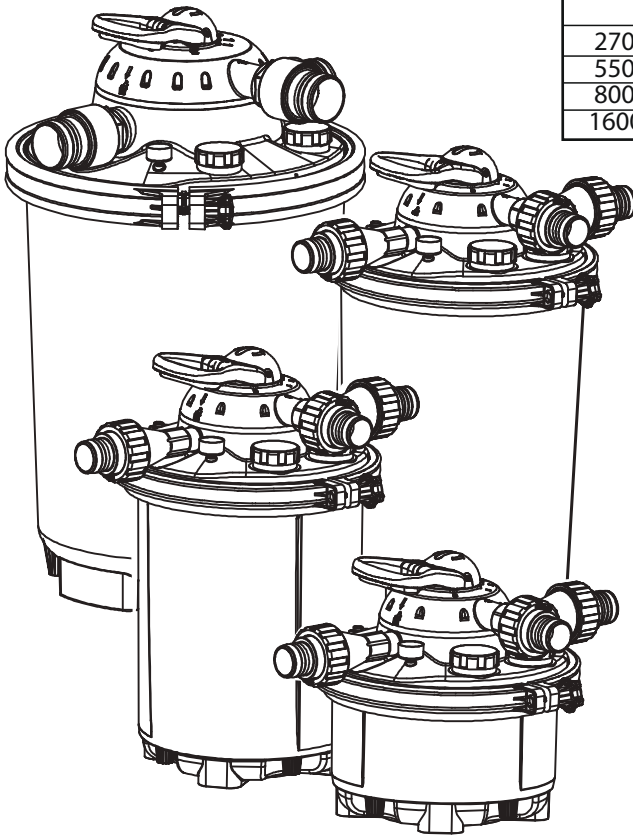

**SAVE THESE
INSTRUCTIONS**

**WARNING! PONDS ARE DANGEROUS TO SMALL CHILDREN!
NEVER LEAVE CHILDREN UNSUPERVISED NEAR A POND.**

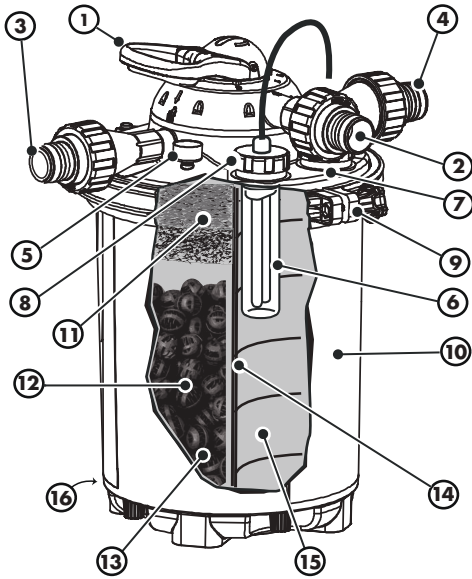

- ① 7-Position Valve Selector
(Filter, Backwash, Rinse, Winterize, Circulate, Closed, Empty)
- ② Inlet
- ③ Waste
- ④ Outlet
- ⑤ Pressure Gauge
- ⑥ UV Bulb/Quartz Sleeve (UV MODELS ONLY)
- ⑦ Access Cap
- ⑧ UV Bulb/Quartz Sleeve Access Cap
- ⑨ Heavy-Duty Lid Clamp with Knob
- ⑩ Filter Drum
- ⑪ Mechanical Filter Pad
- ⑫ BioMatrix Biological Media
- ⑬ Filter Base Plate (Not shown)
- ⑭ Water Chamber Divider
- ⑮ Clean Water Chamber
- ⑯ Bottom Drain /Access for Backwash Air Kit (Not shown)

HOW FILTRATION WORKS

Both biological and mechanical filtrations are essential for every pond; without them, your fish would be harmed by ammonia generated by the accumulated fish waste. The beneficial bacteria bed that builds on the filter media nitrifies any ammonia in the pond making it a healthier environment for aquatic life. Mechanical filtration removes debris in suspension in pond water keeping it cleaner and clearer.

Biomechanical filtration depends on the establishment of a colony of bacteria on the surface of the media that converts dissolved toxic nitrogenous waste to harmless compounds. When the bacteria are given the proper environment, they grow in a thin biofilm on the surface of each piece of media. The media must first establish itself to handle the load of dissolved ammonia. Depending on the water temperature, it can take 2 - 4 weeks for the filter to establish itself in the pond environment. The ultraviolet filtration should be left off during initial seeding to allow the bacteria colonies to grow. The time required varies depending on climate, weather conditions, fish load and feed rates. Until the colonies grow large enough, the pond owner must take care to monitor levels of ammonia and nitrates in the water and take appropriate measures to correct any dangerously high levels. **CAUTION:** Note that smaller filter media cannot be used with this filter. It will pass into valve possibly causing malfunction or it will pass through - back into the pond.

The Filter Pad that is included with the pressure filter serves two purposes. First, it can be used to quickly filter water with particulate solids and debris at the start of pond season - before the

biological filtration has had time to establish. Second, it can be used to polish water anytime pond water has become cloudy. **THE FILTER PAD SHOULD BE USED AT START-UP AND AFTERWARD AS REQUIRED; IT MUST BE REMOVED BEFORE DOING A BACKWASH CYCLE.**

The ultraviolet clarifier included with some models produces a wavelength of light that inhibits algae from reproducing by damaging its DNA. Please note that UV light does not kill string algae that cling to the sides of ponds.

NOTE: This filter is intended to pull suspended solids out of the water column. It is NOT designed to remove leaves and large solids from the pond. It should not be used as a pond vacuum. All pumps used with this filter must be used inside a Pump Bag or with a Skimmer or prefilter to prevent large debris from entering the filter chamber and blocking the biological filtration.



ELECTRICAL PRECAUTIONS

Always use a properly grounded outlet. Do not immerse the plug in water. **DO NOT REACH INTO THE WATER TO REMOVE THE PLUG. TURN OFF CIRCUIT FIRST.** A "drip loop" in the cords should be used. A "drip loop" is a loop in the cord below the level of the receptacle or plug that prevents water from traveling along the cord. The national Electric Code requires that a ground fault interrupter circuit (GFCI) be installed in every branch circuit supplying the fountain or pond equipment. Your dealer can supply GFCI units. **NEVER REMOVE GROUND PIN FROM PLUG.**

WARNING: FOR YOUR PROTECTION, ALWAYS UNPLUG THE UNIT FROM ITS POWER SOURCE BEFORE INSTALLING OR SERVICING. DO NOT REACH, REMOVE OR DISASSEMBLE BEFORE YOU DISCONNECT POWER.

CHOOSE FILTER / PUMP LOCATION

This filter must be connected to an external water pump.

The water pump can be submersible or above ground depending on your preference.

Please note the following:

- The intake for the water pump should be positioned at the opposite end of the pond from the water return for best circulation
- The return hose from the pressure filter outlet to the pond or water feature should be kept as short as possible to reduce back pressure to the filter. Long tubing and /or undersized tubing connected to the outlet port of the pressure filter produces back pressure.
- Use the largest diameter tubing possible to reduce tubing friction loss and get the best flow.
- Note that the bottom drain should be accessible after installation.

TYPICAL ABOVE-GROUND INSTALLATION

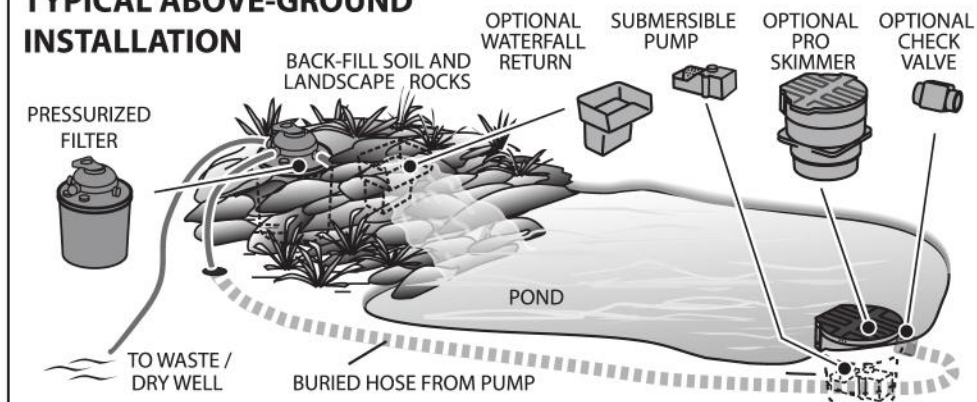

NOT RECOMMENDED

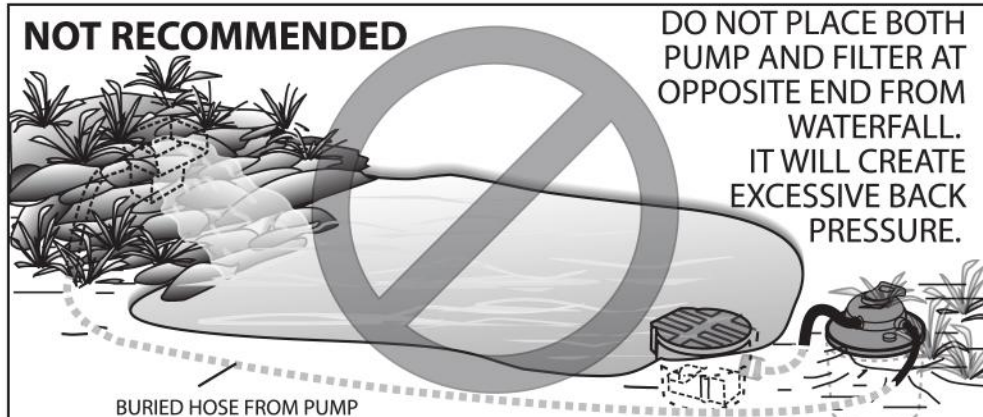

CHOOSE THE CORRECT PUMP

Your Pressurized Filter System works best within a certain range of flow and pressure. See Table. Exceeding these values will cause leakage or breakage of the filter or its components and void the warranty.

If your water feature (for example - waterfall or fountain) requires more water than the recommended flow, a Bypass Loop can be used in-line to divert some of the water flow directly to the water feature. This will avoid overburdening and possibly damaging the pressure filter. See our website for information on Valved Bypass Kit - Item# 15015 to set up a Bypass Loop.

Filter Model	Pumps up to:	Maximum Pressure
2700	3000 GPH/11350 LPH	15 PSI/1 BAR/103kPa
5500	6000 GPH/22700 LPH	15 PSI/1 BAR/103kPa
8000	8000 GPH/30300 LPH	15 PSI/1 BAR/103kPa
16000	9000 GPH/34000 LPH	20 PSI/1.4 BAR/138kPa

FILTER SET-UP

UNPACK FILTER and remove contents.

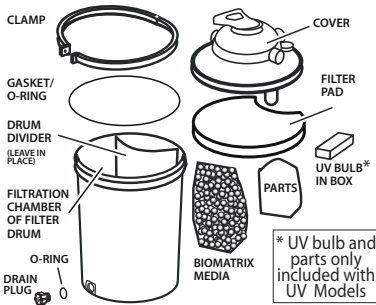

Open clamp to remove cover and separate parts keeping all O-rings, gaskets and connection surfaces clean of debris. If the model includes an UV clarifier, note that the UV quartz sleeve protrudes from the bottom of the cover. Cautiously place the cover to avoid damaging the quartz sleeve. The UV lamp is packed in the upper protective packaging in a small separate box. Handle it carefully; it will be installed after the cover is reattached. Units with the UV clarifier include a clear extra UV port cap. This must be kept to cover UV port when winterizing. **RELOAD FILTER DRUM** - Check that the drum divider is properly aligned in the filter drum tracks and is fully seated down to the bottom of the filter drum. Pour Biomatrix Ball Filter media from plastic bag back into filtration chamber of filter drum. Place Foam Filter pad in upper end of filtration chamber.

☞ CHECK THAT DRAIN PLUG IS IN PLACE AND TIGHTENED SECURELY.

FOR BACKWASH AIR KIT ONLY

Figure 1

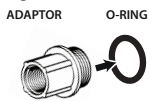

Figure 2



INSTALL ADAPTOR* - ONLY if you are planning to use the *Pondmaster Backwash Air kit (sold separately)*. Before using filter, install adaptor into bottom drain opening on pressure filter. Use Teflon tape on threads. See Figures 1 & 2. Follow instructions provided with Backwash Air kit.

*NOT INCLUDED (SEE PAGE 9)

IMPORTANT! ● CLEAN ● LUBRICATE ● ALIGN

INSTALL GASKET / O-RING Note that an O-Ring or gasket must always be clean, properly seated and lubricated before reattaching the cover. Note that on some models the gasket may have been pre-installed.

Models 2700, 5500 & 8000 GASKET seats in track. Use silicone grease (supplied in small packet) to lubricate entire gasket before assembly.

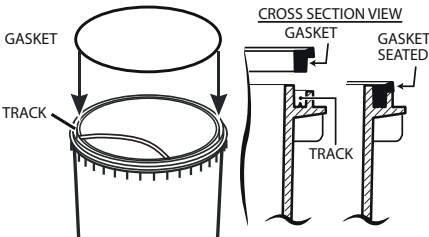

Model 16000 O-RING seats on top step of outer flange. First position O-ring onto step as shown then cover all exposed surface of O-ring with silicone grease (supplied in small packet).

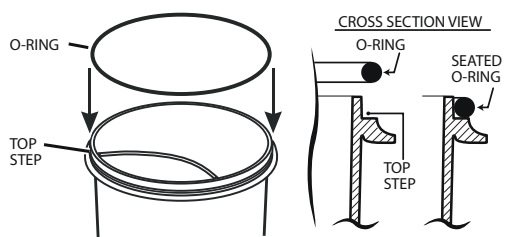

ONLY LUBRICATE WITH SILICONE GREASE

SILICONE GREASE



Never use petroleum based lubricants on O-rings or gaskets

ALIGN COVER NOTCH

Note position of alignment tab on filter drum and matching notch on filter cover. Press cover straight down; Do not twist or shift as it may unseat the gasket / O-ring.

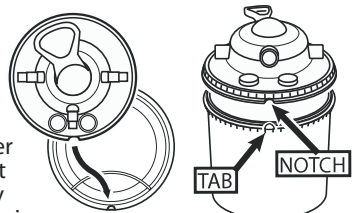

SECURE COVER WITH CLAMP

Once cover is pressed down evenly, place the clamp around the drum and cover flanges and pull the open end closed. Note that it is best to position the open end of the clamp away from hose connections for easy access to the tightening knob once hoses are attached. Insert hex bolt through opening with hex recess and push through to opening on other end of clamp. Attach the tightening knob to hex nut and turn until clamp closes completely.

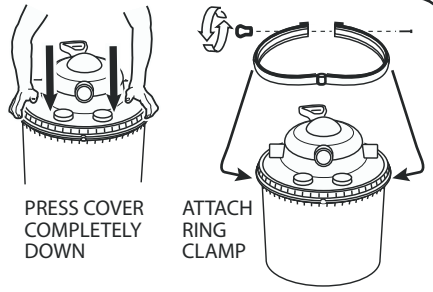

ULTRAVIOLET CLARIFIER INSTALLATION

If your pressure filter was supplied with a UV clarifier, the bulb must be installed. Unscrew the UV cap Lock-Ring and pull straight up. Insert lamp into socket and carefully lower into the quartz sleeve already mounted in the cover. Turn Lock ring clockwise until tight. Be cautious not to cross thread the lock ring before tightening. Check that extra UV port cap is tight before operating filter.

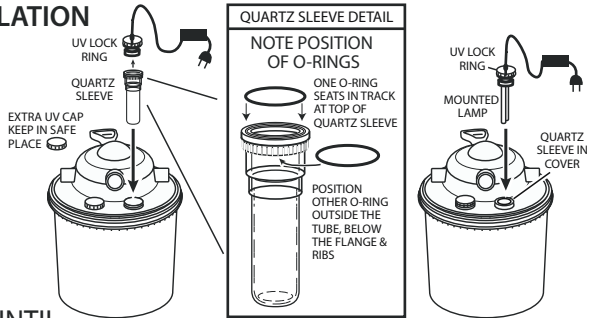

DO NOT OPERATE UV CLARIFIERS UNTIL

READING ELECTRICAL PRECAUTIONS AND UV CLARIFIER OPERATING INSTRUCTIONS

TUBING CONNECTION OPTIONS

The adaptors supplied with the pressure filters are configurable for connection to flexible hose using supplied barbed fittings or rigid PVC using PVC cement*.

Filter	Barb fitting / Flexible Hose		Slip fitting / Rigid PVC
	US	Metric	US
Model 2700	1 1/2"	32mm and 40 mm	1 1/2"
Model 5500	1 1/2" and 2"	32mm and 40 mm	1 1/2" and 2"
Model 8000	1 1/2" and 2"	32mm and 40 mm	1 1/2" and 2"
Model 16000	3"		3"

MODEL 16000

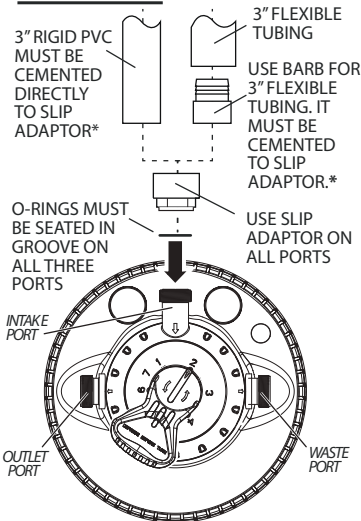

WHEN USING RIGID PVC PIPING, 3" UNION CONNECTIONS* MUST BE USED ON ALL 3 LINES FOR ABILITY TO DISCONNECT AND REMOVE LID.

MODEL 8000, 5500 & 2700

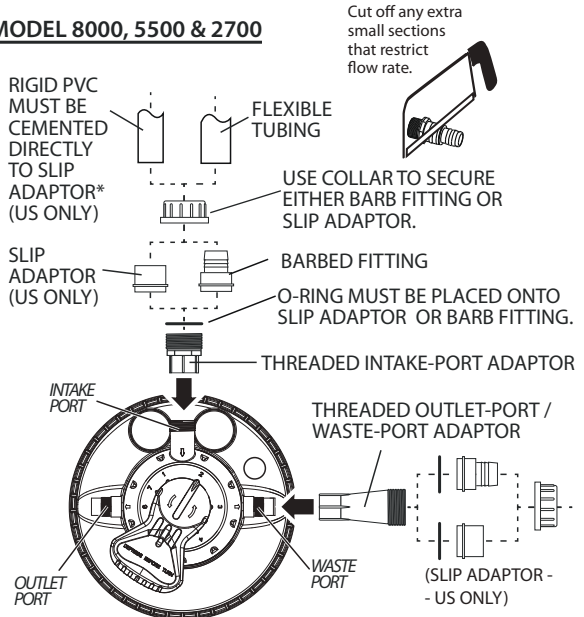

* 3" Unions & PVC Cement not included. Carefully follow the instructions supplied with PVC cement.

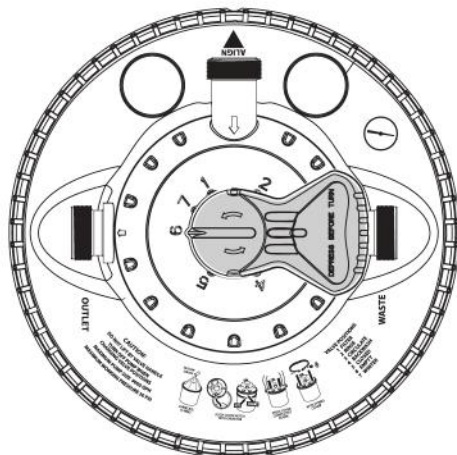

VALVE POSITIONS

The valve has 7 positions. They are numbered for identification.

CAUTION: Never lift filter using the valve position handle.

CAUTION: Always turn off pump when changing valve positions.

Change valve positions by pressing down on handle, rotating until pointer points to desired number and release. (In this illustration the pointer is at position 6.)

Check that handle is not in between settings when releasing handle.

1: FILTER: Water passes through media in filter drum and back up through UV/Clean-water chamber to water outlet port

2: RINSE: Water flows through valve and exits from the waste port. This is used to wash away dirt particles in the valve after a backwash cycle.

3: CIRCULATE (BYPASS): This setting passes water through the valve intake and exit through the outlet port directly without entering the filter chamber. It is useful if the pond is being medicated and filtration is undesirable.

4: BACKWASH: Water flow reverses through clean-water chamber then backwards through the filter media and exits through the waste port.

5: CLOSED: This position closes off the intake and stops water from entering the valve. The pump must be off when in this position. Use this setting temporarily when servicing the pump.

6: EMPTY (DRAIN): Water enters the intake and is directed to the waste port without filtration. This is used to empty the pond should the need arise.

7: WINTER: This is a neutral position that equalizes pressure between all three ports. Use this setting - with the pump off - when filter is shut down during winter.

FILTER OPERATING INSTRUCTIONS

1) Put the valve to position 1 "FILTER".

2) Turn on pump and check all connections. Check that pressure gauge pointer is in the Green zone. Run filter with Foam Filter pad and Biomatrix Ball media at first.

The Biomatrix Ball media works best when the filter's bacteria colonies are established. It takes a few weeks for the bacterial colonies to grow on the media and be effective for filtration. During the waiting period for biological filtration, the filter pad will collect debris and mechanically filter the water without disrupting the growing biological colony. If water flow becomes sluggish, the foam filter pad may have accumulated too much debris and should be removed, rinsed and replaced into filter. It may be necessary to do this several times until the biological filtration is established.

After a few weeks the filter pad can be removed, rinsed and set aside for future use. It can be used anytime the pond is stirred up or appears to be cloudy.

3) A backwash schedule should be established to maintain the bacteria colony level on the biomatrix ball media. This should be done every few weeks depending on your pond conditions. Bio load, sunlight, temperature and feeding habits all affect the need for backwash. The best way to tell when to backwash is to monitor water flow rate and the pressure gauge. If water flow rate diminishes or if the gauge indicator has moved to the top or past the green zone it is time to backwash. The backwash alone may not dislodge heavy bacteria colonies; it may be necessary to open the filter and stir up the Biomatrix media before backwashing. Note that for a more substantial power backwash, the Pondmaster Backwash Air kit can be attached to the drain valve to force air through the media releasing the excess waste. See Accessories section.

FILTER OPERATING INSTRUCTIONS (continued)

REMOVING and REPLACING COVER

Cover can be removed to perform filter maintenance. Follow these steps:

- 1) Turn off power to pump and UV units
- 2) Disconnect hoses that are attached to the cover.
- 3) Always lift cover straight upwards after removing clamp.
- 4) Place cover down carefully; UV quartz sleeves and flow diffuser protrude from the bottom of the cover.
- 5) Always make certain that O-Ring and track are clean and lubricated.
- 6) Align Tab & Notch and Place cover straight down - - DO NOT TWIST OR THE O-RING/GASKET MAY UNSEAT.
- 7) Reattach clamp.
- 8) Reattach hoses.
- 9) Turn on power. *Always check cover fit and hose connections before leaving unattended.*

BACKWASH CYCLE

**NOTE:
REMOVE FOAM FILTER PAD
BEFORE BACKWASHING**

To run a backwash cycle:

- 1) Turn off Pump.
- 2) Check that waste hose is properly directing waste water to a dry well or garden area.
- 3) Set valve to #4 BACKWASH and run the pump for a few minutes. *
- 4) Turn off pump.
- 5) Set valve to position 2 "RINSE".
- 6) Turn on pump for 20-30 seconds.
- 7) Turn off pump
- 8) Reset the valve to position 1 "FILTER"
- 9) Turn on pump.
- 10) Repeat Backwash. Multiple backwash cycles may be needed.

*NOTE: If filter media is extremely clogged, it may be necessary to open the filter and manually stir the media to loosen excess waste before back washing.

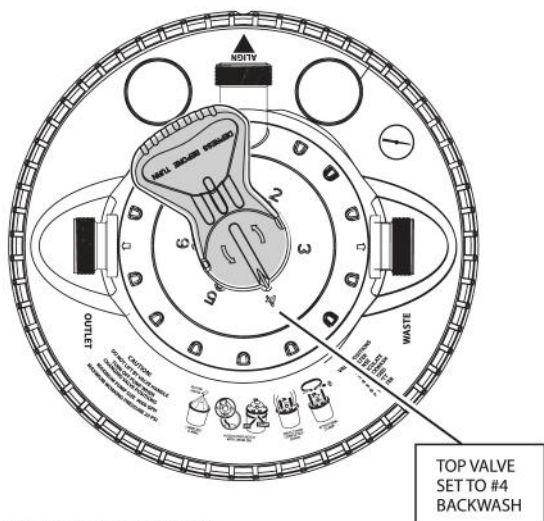

USING THE PRESSURE GAUGE:

The Pressure Gauge should be checked the first time the pump is turned on. The pointer should be in the green zone to ensure that the installation is correct.

The Gauge should not solely be relied upon to indicate the need for a backwash. Always monitor water flow and water clarity to determine when backwashing is necessary.

If reading on gauge is ever in RED zone, turn off the pump and check for the cause of the excessive back-pressure. Do not run the filter when the pointer is in the red zone.

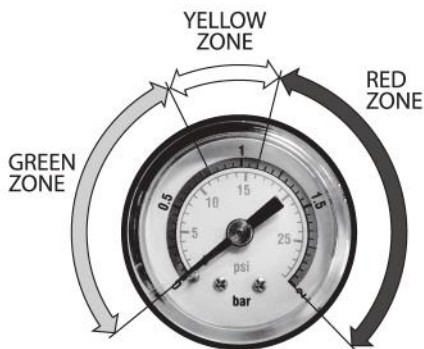

UV CLARIFIER OPERATING INSTRUCTIONS:

If your pressure filter was supplied with an UV clarifier or if you are adding a UV Clarifier, note the following: The UV Clarifier will not light up when removed from the pressure filter cover. It incorporates a safety switch to disable power when not assembled.

To use the UV feature, unscrew the UV cap/socket assembly from the cover and push the bulb into the bulb socket. Carefully reinsert the UV bulb straight down into the top opening with the quartz sleeve in place. Rotate the cap clockwise until tight. Plug the power cord into a grounded GFCI protected outlet to check. The top of the UV cap is clear for observation that UV is functioning. Disconnect power until the filter is running.

IMPORTANT NOTES:

- 1) If installing the UV quartz sleeve into the Filter Cover make certain that O-Rings are properly installed.
- 2) Completely assemble UV Clarifier into filter with Quartz sleeve installed before supplying power. This will assure that safety switch is engaged and unit will light. The light can be safely checked by viewing through the Clear plastic UV cap on the fixture.
- 3) Never stare at or expose skin to UV light. It can damage eyesight or burn skin.
- 4) Do not defeat the safety features by bypassing the built in safety switch.
- 5) A second port is available to install an additional UV unit. The 16000 model uses both ports. See Optional Accessories.

Ballast is enclosed in a double insulated case. Never cut power cord. Do not modify the plug provided with the appliance; if it will not fit the outlet, have a proper outlet installed by a qualified electrician.

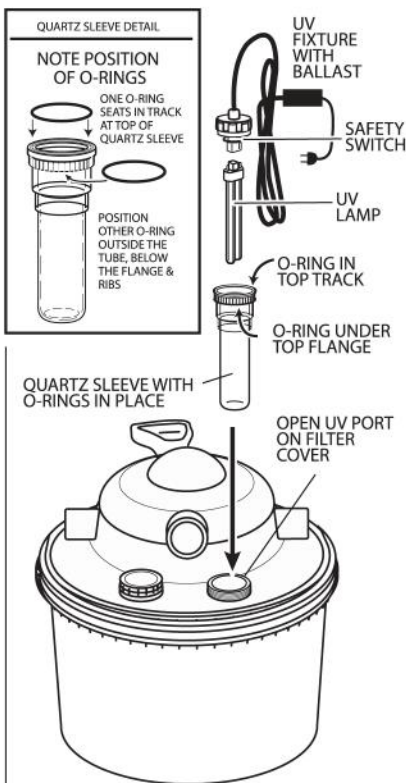

NOTE: YOUR FILTER AND UV ACCESSORIES MAY VARY FROM REFERENCE ILLUSTRATION.



DANGER: ULTRAVIOLET RADIATION. Disconnect Power Before Replacing Lamp. Connect only to a circuit that is protected by a ground-fault circuit-interrupter (GFCI). **WARNING:** Risk of Electric Shock. Disconnect power before servicing. Do not immerse in water. For household use only.

UV MAINTENANCE

- 1) Effective useful bulb life is one season. The bulb will continue to illuminate long after the UV radiance has diminished. For best results replace bulb annually.
- 2) Periodically clean the quartz sleeve. Always allow unit to cool before disassembly. Carefully disassemble and clean outside using a solution of 30% white vinegar to water. Allow to soak to soften scale or build-up. Use a bottle brush and mild detergent to clean inside of quartz sleeve. Make certain inside of tube is dry before reassembly. Lubricate O-Rings with **Silicone grease** before reassembling. **NEVER USE PETROLEUM BASED LUBRICANTS ON O-RINGS.** Note that if Quartz sleeve or UV lamp shows any signs of cracks or fissures it cannot be used and must be replaced.

Hg

MERCURY WARNING: LAMP CONTAINS MERCURY, MANAGE IN ACCORDANCE WITH DISPOSAL LAWS. WWW.LAMPRECYCLE.ORG

WINTERIZATION

CAUTION: During harsh winters, water left in the drum may freeze, expand and crack the drum. If necessary, the filter can be drained and winterized at the end of the season. If you live in an area that doesn't experience freezing temperatures, you may never need to do this. To empty the water from the filter drum, it is not necessary to open the filter.

- 1) Turn off the pump and disconnect the power source to the UV.
- 2) Turn the Valve to position #7 WINTER.
- 3) Remove the drain plug at the bottom of the filter to empty the filter from the bottom. Note that the drain plug adaptor has a 1/2" NPT female thread for attachment to 1/2" NPT male fittings. If you want to attach a hose to the bottom drain, you can purchase a 1/2" NPT fitting to connect to the bottom drain adaptor and to a hose. 1/2" NPT fitting are available at hardware stores or irrigation supply centers
- 4) If your set-up includes a UV Clarifier, rotate the lock ring counter clockwise to remove it. Pull the socket cap/light unit assembly straight up, being careful not to break the UV lamp. Disconnect lamp from socket by grasping the plastic base of the lamp and carefully pulling it straight apart from the socket cap. Remove the quartz sleeve from the filter cover by pulling straight upwards. Pack the quartz sleeve and UV lamp carefully and store it with the O-ring and socket cap/ ballast for winter. Cover the open UV port with the clear extra UV port cap that was placed in storage. DO NOT ALLOW WATER TO GET INTO UV QUARTZ SLEEVE AND FREEZE. IT WILL CRACK WHEN WATER FREEZES.

OPTIONAL ACCESSORIES

CLEARGUARD BACKWASH AIR KIT: For more thorough backwashing and agitation in the media filter chamber to break up the stubborn debris. It connects through the drain plug at the bottom of the pressure filter.

Pond Filter Capacity	Maximum water pump size	Clearguard Backwash Air Kit Item #	
		No airpump included	Airpump included (120V)
2700 GAL / 10000 L	3000 GPH / 11350 LPH	15675	15660
5500 GAL / 20000 L	6000 GPH / 22700 LPH	15675	15660
8000 GAL / 30000 L	8000 GPH / 30300 LPH	15675	15670
16000GAL / 60000 L	9000 GPH / 34000 LPH	15675	15670



UV Clarifier - Upgrade your filter by adding an ultraviolet clarifier to a non UV unit or add a second UV clarifier using the extra port for additional algae control.



Filter Item #	Wattage	Voltage	
		120V	230V
2700	9W	15610	15611
5500	18W	15620	15621
8000	18W	15620	15621
16000	18W	15620	15621

Replacement Filter Pads -

Available to replace the filter pads that were supplied with the pressure filters. For 2700, 5000 & 8000 series Pressure filter use ITEM15640. For 16000 Pressure filters use ITEM 15645.

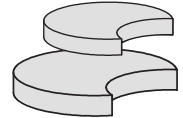

Biomatrix 1 1/4" (32mm) Ball Media - Increase the biological filtration by adding more media. The Biomatrix Ball media is the only media recommended for use with ClearGuard pressure filters. Available in bags of 300 ITEM # 15650.

Caution: Do not use undersized media; it will get caught in valve and possibly damage the filter.

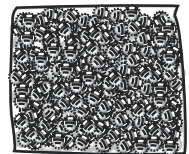

TROUBLE SHOOTING

CONCERN	POSSIBLE CAUSE	SOLUTION
Filter output is sluggish.	Filter Pad is clogged.	Remove rinse and replace filter pad.
	Media needs cleaning.	Backwash filter. See BACKWASH CYCLE.
	Pump intake is clogged, Pump is undersized or requires maintenance.	Check pump and clear debris. Use a Pump Bag around pump to prevent future clogging. See pump manual.
	Discharge is clogged.	Remove blockage from discharge
	Tubing is too small, too long or kinked.	Test filter with valve positioned to #3 Circulate (Bypass) position. This tests your hose and pump set-up by passing water directly through valve, not filter. If still slow, make adjustments to set-up.
Pressure Gauge pointer does not move	Filter has no active bacterial colonies yet.	Gauge may not show back pressure if filter is operating normally. Check weekly.
Pressure Gauge pointer is in yellow zone.	Debris has grown too thick.	Remove and rinse the filter pad. Backwash. If necessary, stir up Bio-Media manually or with Air turbulence before backwashing. Check weekly.
	Pump is oversized.	Replace with a recommended pump or split water flow between pump and filter intake using a Valved Bypass.
	Set-up causes excessive back pressure.	Test filter with valve positioned to #3 Circulate position. This tests your hose and pump set-up by passing water directly through valve, not filter. If still slow, make adjustments to set-up.
	Outlet is clogged	Check for obstructions and clear outlet.
Filter drum is leaking at perimeter.	O-Ring or Gasket is missing, twisted, dirty or was not lubricated.	Turn off pump. Open filter and remove, clean, re-seat and lubricate O-Ring/gasket. Attach cover, checking alignment of tab & slot and thoroughly tighten clamp knob.
	Water pressure is too high.	Pump is too large. Install a Valved Bypass to redirect excessive water pressure buildup. Water can be diverted directly to your waterfall. Set-up is creating back pressure due to hose configuration. Redo set-up to eliminate back pressure on the outlet port of the filter.
UV does not light.	Power supply problem	Check GFCI, Confirm all plugged connections.
	Improper installation sequence.	Always have unit completely installed before powering up the UV. It will not light if plugged in first and then assembled.
	Bulb has dislodged from socket.	Turn off pump, open UV and reattach bulb. Reassemble and apply power.
Filter Clogs right away.	Pressure filter is clogged with leaves or other large waterborne debris.	Never use the filter as a "Vacuum". For a pond with a lot of debris use or rent a "pond vac" or remove the heavy debris manually.
		Use a pond skimmer and/or pump bag to prevent large debris from entering pump.

WARRANTY

Pondmaster Filtration systems are warranted against failure due to defects in materials and/or workmanship for one year from date of purchase. This warranty covers defects occurring under normal use and applies to the original purchaser at retail and may not be transferred. The warranty and remedies set forth herein are conditional upon proper installation, use, maintenance, storage, and conformance with the applicable use. It will be based upon Danner Mfg. discretion as to whether the defects are of manufacturing origin. Any damages due to improper installation are not covered by this warranty. This warranty does not apply to appearance or accessory items. This warranty does not include damage due to handling, transportation, unpacking, setup, installation, repair or replacement of parts supplied by any other than Danner Mfg.; improper maintenance, modification or repairs by the purchaser; abuse, misuse, neglect, accident, fire, flood, or other acts of God. Any oral statements about this product made by the seller, the manufacturer, their representatives or any other parties do not constitute warranties and shall not be relied upon by the user and are not part of this contract. Neither the seller nor the manufacturer shall be liable for any injury, loss or damages, direct, incidental, or consequential, including but not limited to incidental or consequential damage for lost profits, lost sales, injury, and inability to use the product and the user agrees that no other remedy is available. Before using, the user shall determine the suitability of the product for their intended use and the user shall assume all risk liability whatsoever in connection therewith. To validate this warranty, keep your proof of purchase (copy of sales receipt from a certified Pondmaster dealer). Warranty covers the repair or prorated replacement of the Danner Mfg. products. Danner Mfg. denies all liability for any other loss including but not limited to loss of equipment, income, livestock, or personal injury.

THE FOLLOWING VOIDS WARRANTY:

PRODUCT LABELS ARE DEFACED OR REMOVED. PRODUCT IS IMPROPERLY INSTALLED OR MAINTAINED BY USER OR THEIR AGENT. PRODUCT IS ABUSED, MISUSED, OR DAMAGED BY USER OR THEIR AGENT. PRODUCT IS NOT WINTERIZED OR REMOVED FROM SERVICE AND DRIED DURING FREEZING CONDITIONS. PRODUCT DAMAGE IS CAUSED BY OVER-TIGHTENING FITTINGS ON VALVE PORTS.

