

Birch 26' H x 16' W	Redwood 36' H x 8' W	Spruce 34' H x 12' W	Balsam 21' H x 36' W	Linden 26' H x 46' W
------------------------	-------------------------	-------------------------	-------------------------	-------------------------

Quick Facts

Complete Package Includes: <ul style="list-style-type: none"> • Motor Unit • Control Panel • Float with Screens & Mooring Lines • UL, CSA & NEC Approved Underwater Rated Cable • 5 Interchangeable Nozzles 		<ul style="list-style-type: none"> • Total Package Listed by ETL to UL/CSA Standards • Top Intake for Shallow Operation • Salt Water Compatible • Packaged for Convenient Shipping 	
Motor Unit <ul style="list-style-type: none"> • 7.5HP, Voltage Operating Range of 208-240V, 3 Phase • Class B Insulation • 1750 RPM Avg, 1800 Nominal • Oil Cooled • Continuous Duty Rated • 17mm Top and 20mm Bottom Bearings • Thermal Overload Protection • Dual, Fully Unitized Heavy-Duty Carbon Ceramic Mechanical Seal • Series 300 Austenitic Stainless-Steel Can • Cast Stainless Steel Motor Top • Sacrificial Zinc Anode Installed on 316 SST Shaft 		Float <ul style="list-style-type: none"> • UV Resistant High-Density Polyethylene • Single Piece • 300 Series Stainless Steel Hardware • Protective Coated, 300 Series Stainless Steel Bottom Screen • ¾" Mesh Overlay Screening • ¼" Mesh Overlay Screening • Three 50' Braided Nylon Mooring Ropes 	
Fountain Components <ul style="list-style-type: none"> • Custom Thermoplastic Impeller • UV Resistant Thermoplastic Cone & Fountain Housing • 300 Series Stainless Steel Hardware • 5 Interchangeable Thermoplastic Nozzles • Tool-Free Nozzle/Pattern Changing • Additional Premium Nozzles Available 		Power Cable <ul style="list-style-type: none"> • UL, CSA & NEC Approved Underwater Rated Cable • 4 Wire (L1, L2, L3, G) • Quick Disconnect • Stainless Steel Strain Relief • 6' Flex Sleeving Protection • Optional Flex Sleeve for entire cord length available 	
Power Control Center <ul style="list-style-type: none"> • UL 508 Listed • NEMA Type 3r/4x Thermoplastic Enclosure • GFCI Protection with 5ma Trip Level • Surge Protector • Motor Starter with Adjustable Overload • Hand-Off-Auto Switch • 24 Hour Mechanical Timers for Fountain & Light • Terminal Block Wiring • 5 Wire Power Required (L1, L2, L3, N, G) 		Optional Lighting <ul style="list-style-type: none"> • See Lighting Specs 	

Model #	HP	Cord Length (Feet)	Cord Gauge*	Voltage/Phase/Hz	Running Amps	Lock Rotor Amps	Sugg. Pond Size (SA)*	Min Depth of Operation (Inches)	Shipping Weight (Lbs)	Number of Boxes
7.3JF100	7.5	100	12/4	208-240V 3/60	20	97	3.5	28		4**
7.3JF150		150	10/4							
7.3JF200		200	10/4							
7.3JF250		250	8/4							
7.3JF300		300	8/4							
7.3JF400		400	6/4							
7.3JF500		500	6/4							

* Actual shape, depth, & oxygen demand should be considered when selecting a unit size.

** Ships motor freight only.

500' and longer cord lengths available by custom order only.

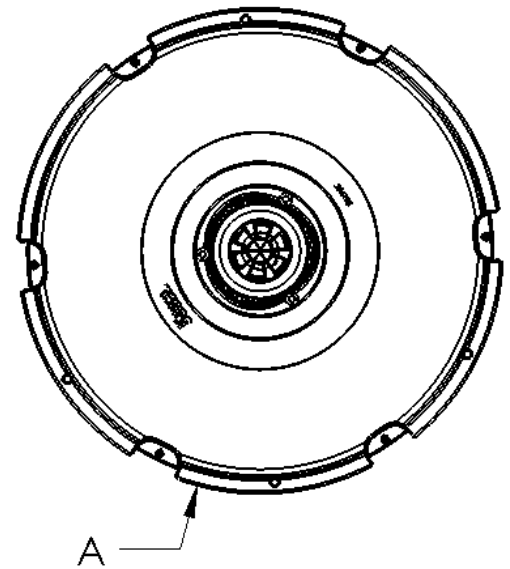
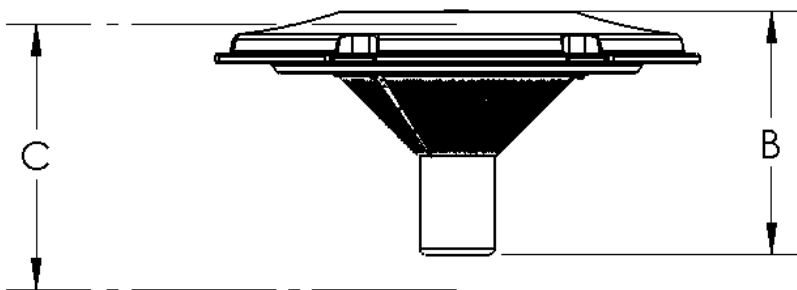

A	Float Diameter	47.5 Inches
B	Unit Height	24 Inches
C	Min Operating Depth	28 Inches