

Birch 24' H x 14' W	Redwood 32' H x 6' W	Spruce 31' H x 12' W	Balsam 18' H x 34' W	Linden 24.5' H x 46' W
------------------------	-------------------------	-------------------------	-------------------------	---------------------------

**Quick Facts**

<p><b>Complete Package Includes:</b></p> <ul style="list-style-type: none"> <li>• Motor Unit</li> <li>• Control Panel</li> <li>• Float with Screens &amp; Mooring Lines</li> <li>• UL, CSA &amp; NEC Approved Underwater Rated Cable</li> <li>• 5 Interchangeable Nozzles</li> </ul>		<ul style="list-style-type: none"> <li>• Total Package Listed by ETL to UL/CSA Standards</li> <li>• Top Intake for Shallow Operation</li> <li>• Salt Water Compatible</li> <li>• Packaged for Convenient Shipping</li> </ul>	
<p style="text-align: center;"><b>Motor Unit</b></p> <ul style="list-style-type: none"> <li>• 5HP, Voltage Operating Range of 208-240V, Single Phase</li> <li>• Class B Insulation</li> <li>• 1750 RPM Avg, 1800 Nominal</li> <li>• Oil Cooled</li> <li>• Continuous Duty Rated</li> <li>• 17mm Top and 20mm Bottom Bearings</li> <li>• Thermal Overload Protection</li> <li>• Dual, Fully Unitized Heavy-Duty Carbon Ceramic Mechanical Seal</li> <li>• Series 300 Austenitic Stainless-Steel Can</li> <li>• Cast Stainless Steel Motor Top</li> <li>• Sacrificial Zinc Anode Installed on 316 SST Shaft</li> </ul>		<p style="text-align: center;"><b>Float</b></p> <ul style="list-style-type: none"> <li>• UV Resistant High-Density Polyethylene</li> <li>• Single Piece</li> <li>• 300 Series Stainless Steel Hardware</li> <li>• Protective Coated, 300 Series Stainless Steel Bottom Screen</li> <li>• 3/4" Mesh Overlay Screening</li> <li>• 1/4" Mesh Overlay Screening</li> <li>• Three 50' Braided Nylon Mooring Ropes</li> </ul>	
<p style="text-align: center;"><b>Fountain Components</b></p> <ul style="list-style-type: none"> <li>• Custom Thermoplastic Impeller</li> <li>• UV Resistant Thermoplastic Cone &amp; Fountain Housing</li> <li>• 300 Series Stainless Steel Hardware</li> <li>• 5 Interchangeable Thermoplastic Nozzles</li> <li>• Tool-Free Nozzle/Pattern Changing</li> <li>• Additional Premium Nozzles Available</li> </ul>		<p style="text-align: center;"><b>Power Cable</b></p> <ul style="list-style-type: none"> <li>• UL, CSA &amp; NEC Approved Underwater Rated Cable</li> <li>• 3 Wire (L1, L2, G)</li> <li>• Quick Disconnect standard</li> <li>• Stainless Steel Strain Relief on 12 AWG &amp; Larger Cords</li> <li>• 6' Flex Sleeving Protection</li> <li>• Optional Flex Sleeving for entire cord length available</li> </ul>	
<p style="text-align: center;"><b>Control Panel</b></p> <ul style="list-style-type: none"> <li>• UL 508 Listed</li> <li>• UL Type 3r/4x Thermoplastic Enclosure</li> <li>• 30 Amp Class A Human Rated GFCB</li> <li>• Surge Protector</li> <li>• 24 Hour Mechanical Fountain Timer</li> <li>• Terminal Block Wiring</li> <li>• 24 Hour Mechanical Timer for Optional Lighting</li> <li>• 4 Wire Power Required (L1, L2, N, G)</li> </ul>		<p style="text-align: center;"><b>Optional Lighting</b></p> <ul style="list-style-type: none"> <li>• See Lighting Specs</li> </ul>	

Model #	HP	Cord Length (Feet)	Cord Gauge*	Voltage/Phase/Hz	Running Amps	Lock Rotor Amps	Sugg. Pond Size (Surface acre)*	Min Depth of Operation (Inches)	Shipping Weight (Lbs)	Number of Boxes
5.1JF100	5	100	12/3	208-240V 1/60	20	97	Up to 2.5	26		4**
5.1JF150		150	10/3							
5.1JF200		200	10/3							
5.1JF250		250	8/3							
5.1JF300		300	6/3							
5.1JF400		400	6/3							
5.1JF500		500	6/3							

\* Actual shape, depth, & oxygen demand should be considered when selecting a unit size.

\*\* Ships motor freight only.

500' and longer cord lengths available by custom order only.

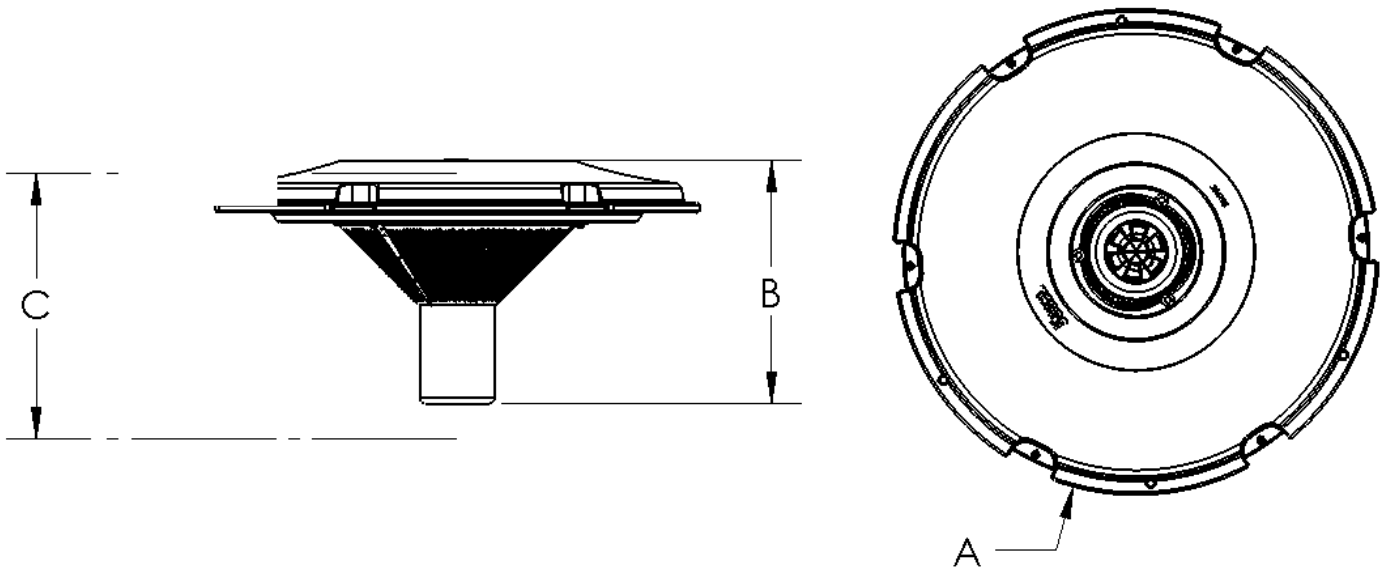

A	Float Diameter	47.5 Inches
B	Unit Height	24 Inches
C	Min Operating Depth	26 Inches