



## 8-PN Check Valve 2.0 Installation



**Dual Union Check Valve 2.0**  
Item #48026

### Installation

#### STEP 1

- Glue and insert a 2.5" section of 2" Flex PVC Pipe into the PVC Male Pipe Adapter 2" x 2" (Ex. 1). Then, glue and insert the other end of the PVC Pipe into the 2" slip on the 1.5" FPT x 2" Slip Fitting with the Threaded Collar attached (Ex. 1).

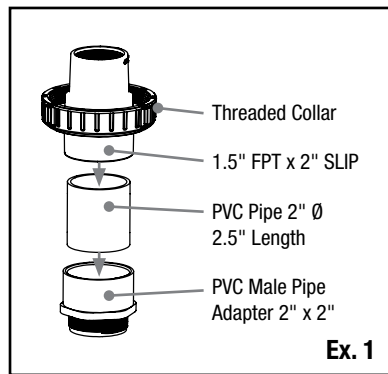

**Ex. 1**

**NOTE:** Prime and glue all glued connections or use a self-priming PVC glue, such as Christy's Red Hot Blue Glue (#29969).

#### STEP 2

- Thread the PVC Male Pipe Adapter 2" x 2" securely into the outlet of the pump (Ex. 2).

**NOTE:** Orient the threaded collar at an angle while threading the adapter into the outlet of the pump.

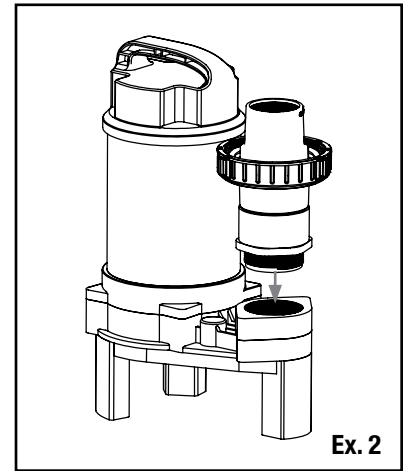

**Ex. 2**

#### STEP 3

- While holding the threaded collar securely, thread the Check Valve 2.0 body onto the threaded collar (Ex. 3).

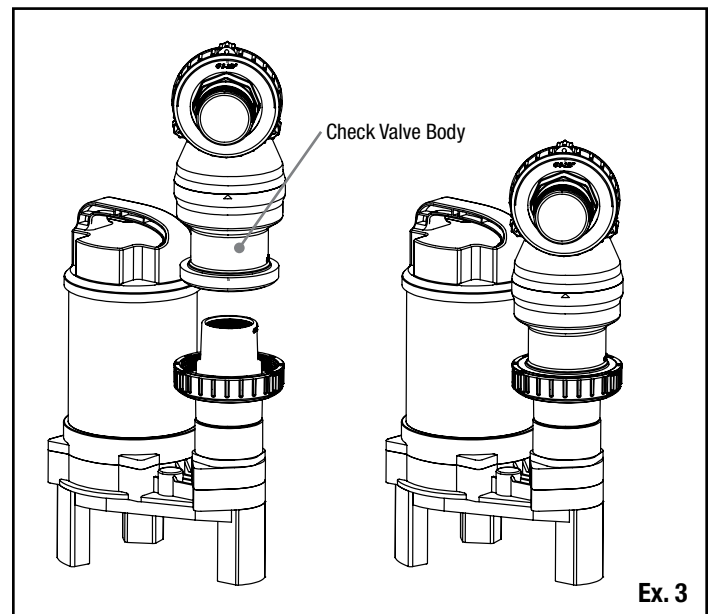

**Ex. 3**

**NOTE:** Due to the tight fit of the valve and collar, be sure to thread the valve body onto the collar.

#### Contact Us

For more information about our company or products, please visit our website at [aquascapeinc.com](http://aquascapeinc.com) or call US (866) 877-6637 CAN (866) 766-3426.

#### Find us on:



[facebook.com/AquascapeInc](https://facebook.com/AquascapeInc)  
[youtube.com/aquascape4](https://youtube.com/aquascape4)  
[twitter.com/AquascapeInc](https://twitter.com/AquascapeInc)

For more information about our company or products, please visit our website at [aquascapeinc.com](http://aquascapeinc.com) or call us at US (866) 877-6637 CAN (866) 766-3426