



Owners Manual

VFX Series Aerators

2400VFX, 3400VFX, 4400VFX

3400HVFX, 4400HVFX



Intertek

3020379
ANSI/UL 778: 2016
Ed.6+R:22Feb2017
CSA C22.2 #108: 2014 Ed.5

Kasco Marine, Inc.
800 Deere Rd.
Prescott, WI 54021
PH (715) 262-4488
www.kascomarine.com

Manual Number
884170

Rev. 7-2020

Contents

Important Safety Instructions. . . .	pg2
General Owner's Instructions. . . .	pg2
Unit Specs. . . .	pg4
VX Pattern Sizes. . . .	pg4
2400VFX, 3400(H)VFX, 4400(H)VFX Parts Included. . . .	pg5
2400VFX, 3400(H)VFX, 4400(H)VFX Assembly. . . .	pg6
VFX Installation Instructions. . . .	pg8
Control Panel Installation. . . .	pg9
C-25 Timer Control Instructions. . . .	pg10
C85 / C95 non-metallic Control Panel Timer. . . .	pg11
2400, 3400, 4400 Parts Diagram. . . .	pg12
Maintenance Recommendations. . . .	pg13
Warranty Policy. . . .	pg14
Troubleshooting Tips. . . .	pg15
Customer Repair Form. . . .	pg17
Registration Information. . . .	pg18

THANKS

We at Kasco Marine, Inc. would like to both thank and congratulate you on your purchase of the VFX model aerator. We appreciate you choosing Kasco and for your purchase. Your decision to purchase Kasco's VFX model Aerator will not disappoint you. The VFX model Aerator will be a great addition to your body of water. It will help improve the water quality by adding much needed oxygen and circulation. It will also enhance the aesthetics of the pond or lake with a beautiful pattern. The lighting package (if purchased) will illuminate your aerator for beauty at night. We thank you for choosing Kasco for your aerator needs and want you to be completely satisfied with your purchase.

Important Safety Instructions

Please read and follow these extremely important safety and handling instructions for your Kasco equipment. Following these instructions will help ensure your safety and the quality performance of your equipment.

- Under NO circumstances should anyone enter the water with the electrical equipment plugged in and/ or in operation. Kasco equipment is ETL approved to UL and CSA standards for safety in water. However, it is NEVER recommended to enter the water with the equipment in operation.
- Caution should be used when dealing with any electrical equipment with moving parts.
- NEVER run the unit out of water. It will damage the seals and create a dangerous situation for the operator.
- Extreme caution should be used around water, especially cold water, such as in Spring, Fall, and Winter, which poses a hazard in and of itself.
- NEVER lift or drag the aerator by the power or light cord. If you need to pull the unit to the side of the pond, use the anchoring ropes.
- Do not use waders in deep ponds/lakes or ponds/lakes with drop-offs, drastic slopes, or soft bottom material.
- Do not use boats that tip easily for aerator installation, such as a canoe, and follow all boating safety rules and regulations, including wearing a PFD. (Personal Flotation Device)

- Single phase aerators are supplied with an internal grounding conductor and/or a grounding-type attachment plug. To reduce the risk of electrical shock, be certain the aerator is properly connected to the Kasco supplied control panel. (refer to the C-25, C-85 & C-95 Control instructions)
- 3 phase aerators (2.3VFX, 5.3VFX) require a startup test after wiring to ensure proper rotation of the propeller. If the propeller is rotating in the opposite direction, the unit will not perform properly and internal damage to the unit may occur. (See 3 phase startup procedure)
- Control panels must be installed a minimum of 5ft(3m in Canada) from the inside wall of the pond, unless separated from the body of water by a fence wall, or other permanent barrier that will make the unit inaccessible to persons in the water.
- Control panels must be installed by a qualified electrician.
- Ground Fault Circuit Interrupters (GFCI) should be tested upon each installation and every month thereafter to ensure proper operation.

General Owner's Instructions

INSPECT THE SHIPMENT

Immediately inspect your Kasco Aerator shipment for any visible damages. Also cross reference the parts supplied with the Parts Included sheet to check for shortages. Shortages should be reported immediately to your Kasco Marine distributor or representative and damages reported to your carrier and Kasco Marine.

CAUTION

WARNING: Under NO circumstances should anyone enter the water with the unit in operation. Always operate the unit in the water and keep people and objects clear of the propeller. Do not lift or pull the unit by the electrical cord. Always use extreme caution around electrical equipment and water situations.

ASSEMBLY & INSTALLATION

Please see the proper Assembly and Installation Instructions enclosed in this manual. Each is specific for your model and size of aerator. Note: Use a nylon tie to help keep the power cords for the unit and lights free of the propeller by tying each cord to either side of the float. If you have a light kit, make sure that the unit cord is tied to one side of the float and the light cord to the other for balance. Note: It is extremely important to test the GFI breaker in the control panel upon each installation/reinstallation of the unit to ensure proper functioning.

WARRANTY

Kasco aerators are the result of over 35 years of design and engineering. Kasco products are built to withstand the toughest conditions. Kasco Marine backs each VFX model aerator with either a 2 Year or 3 Year Warranty depending on the model. This warranty covers any and all manufacturers defects within the warranty period from the date of purchase (See Warranty Section).

USE AND OPERATION

Kasco aerators are designed and engineered for continuous duty, such as on fish farms or other aquaculture applications, or on-demand use, as needed in a recreational water feature. During flotation operation, the water is pulled from 360 degrees around the unit and from below the unit. The water is pulled upward and thrust through the flotation collar into the air. Your Kasco Marine aerator is ready for immediate use (after installation). Make sure to keep the motor housing clean from hard water deposits and/or algae. (See Maintenance Recommendations.) It is extremely important that proper and sufficient voltage is supplied to the aerator motor. Unit should be protected by a GFCI. Control panels must be installed by a qualified electrician. (See Installation instructions).

UNIT STORAGE

When storing units during the offseason, it is important to store them upside down if they are going to be sitting for long periods of time. Units that sit upright on a shelf for many months, or even years have a greater likelihood of seals drying out. Storing upside down will ensure oil is lubricating the seals and prevent drying.

Unit Specs

Model	Voltage	Amps	Lock rotor amps	Control box connection	Aerator connection
single phase aerators					
2400VFX	110-120	5.6	12	C-25 plug in	Plug into C-25
3400VFX	110-120	7.3	18	C-25 plug in	Plug into C-25
3400HVFX	208-240	3.7	9	Hardwire C-85	plug into or hardwire C85
4400VFX	110-120	11.3	40	C-25 plug in	Plug into C-25
4400HVFX	208-240	5.7	20	Hardwire C-85	plug into or hardwire C85

VX Pattern Sizes

NOTE: Pattern sizes listed are approximate. Variations in voltage caused by regional electrical differences or voltage drop due to long power cords may result in reduced pattern sizes.

Model	Height	Width
2400VFX	5'	15'
3400VFX	5.5'	21'
3400HVFX	5.5'	21'
4400VFX	8'	26'
4400HVFX	8'	26'

2400VFX, 3400(H)VFX and 4400(H)VFX Parts Included

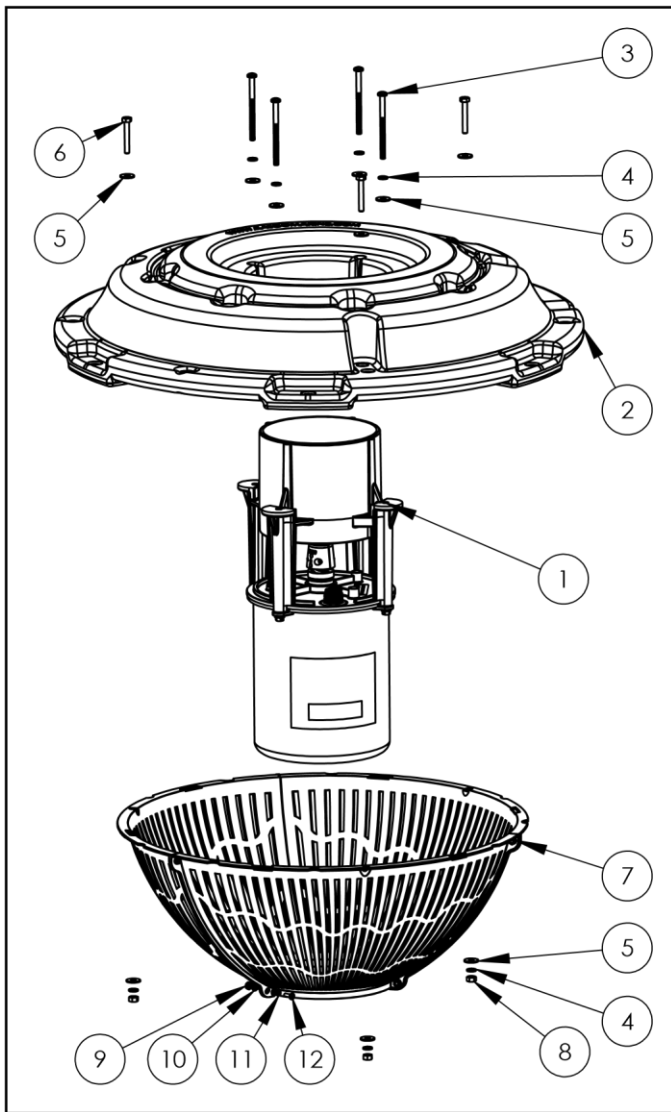

#	Item	Part#	Qty
1	Aerator		1
2	Float	242001	1
3	1/4-20 x 3 1/2" Phillips Pan Head Screw	251210	4
4	1/4" split washers	840537	7
5	1/4" (3/4" OD) Flat Washer	251300	10
6	1/4 -20 x 1-3/4" Hex Head Bolt	475630	3
7	Bottom Screen Section	361540	3
8	1/4"-20 Nut	840536	3
9	#8 nut	771034	6
10	#8 flat washer	361543	12
11	#8 lock washer	771033	6
12	#8 x 3/4" screw	361545	6
Not pictured			
Mooring ropes	990700		2
cable ties	415038		9

Also Included:

- Cord in separate box (1) (depending on size of cord)
- Control Box (C-25 for 120V units in Float box or C-85 for 240V units in separate box) (1) (Not Pictured)

TOOLS & SUPPLIES NEEDED

- Anchors or stakes for installing unit (2)
- # 2 Phillips head screw driver
- 120V or 240V Electrical Supply near pond on a post with room for mounting the C-25 or C-85
- Two 12" pieces of 1" galvanized pipe for weighting ropes (optional)
- #10 x 1" long or longer screw(s) for mounting the C-25 (3) or C-85 (4)
- 7/16" Socket and Ratchet
- 7/16" Wrench
- 11/32" wrench (for #8 fasteners)

2400VFX, 3400(H)VFX, 4400(H)VFX Assembly

1. Rest the float on the 4 legs of the housing.

Align power cord with notch

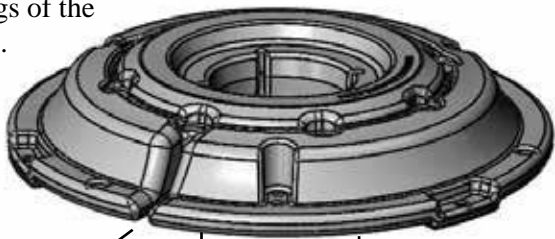

Align bolt holes with legs

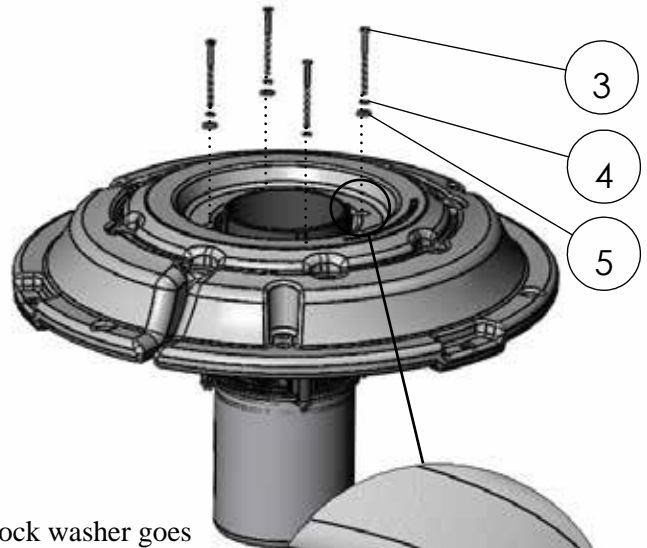

2. Lock washer goes between bolt and flat washer. Tighten down in 4 places

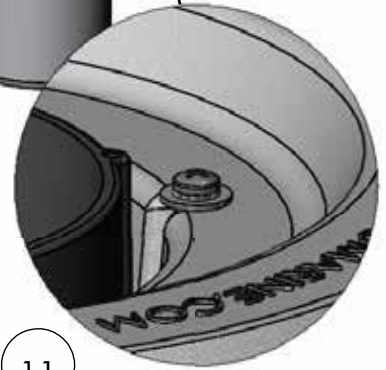

3. Turn over. Bring bottom screen sections together

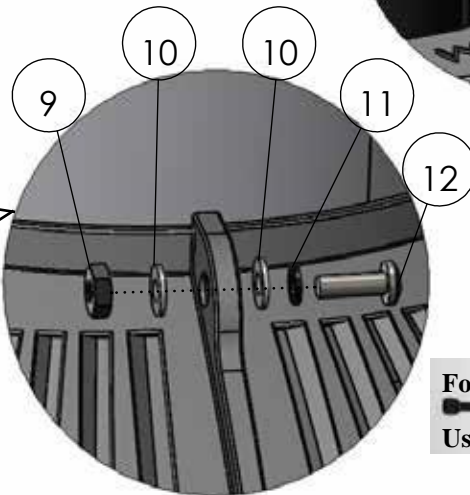
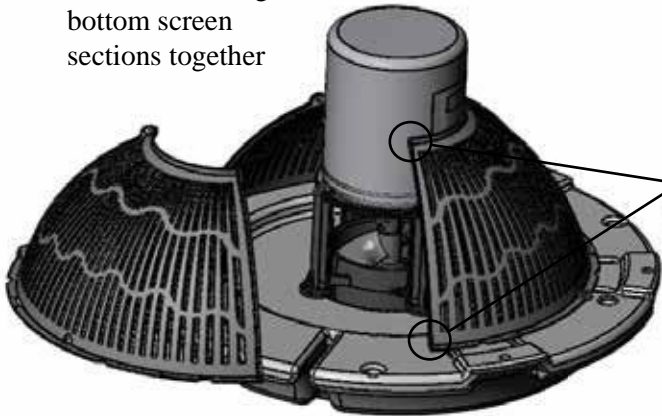

4. Tighten down in 6 places to hold the screen together.

For quicker assembly:

Use cable tie instead

5. Secure the bottom screen to the float in 3 places.

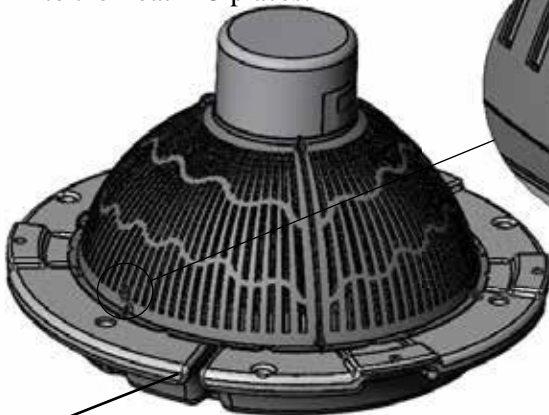

Make sure cord is sticking out of notch

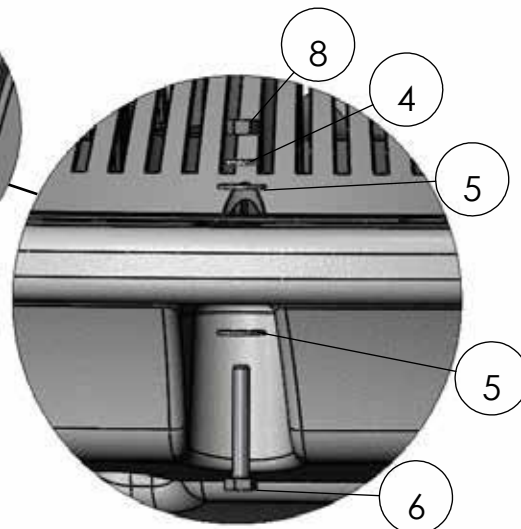
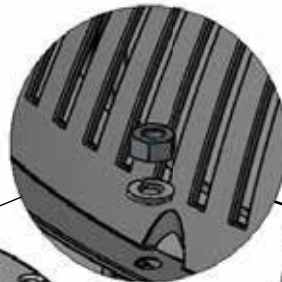

6. Turn upright. Secure power cord to rope hole

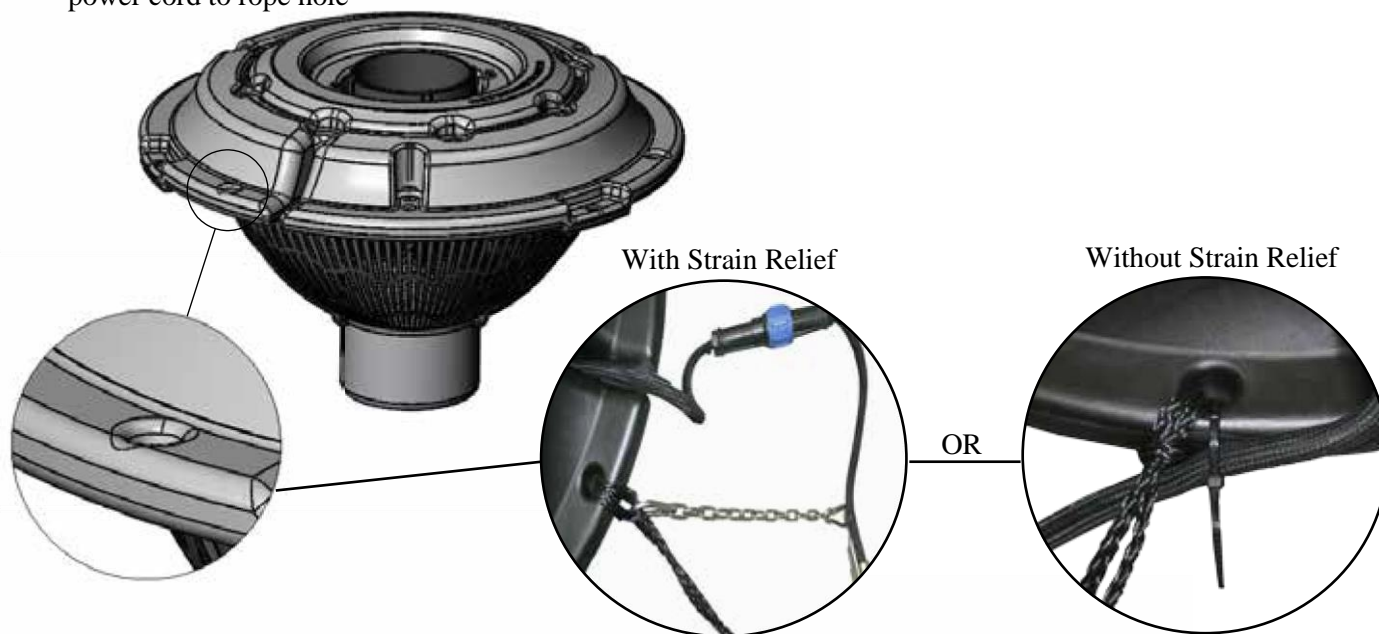

7. If ready to install in the pond, go to Installation instructions. Light Kits can also be installed at this time, go to Light kit instructions.

VFX Installation Instructions

Use the ropes to position the aerator in the desired location in the pond/lake. Anchor the ropes or secure them to the shoreline so the ropes are free of slack, but not tight. To prevent twisting of the unit due to torque, you should place the anchor at least 3 feet from the float for each foot of depth (Ex. A 6 foot deep pond would require an anchor 18 feet horizontally from the float.)

Alternate Installation Instructions:

In ponds where the water level fluctuates significantly, you may need to suspend a small weight (12" of 1" galvanize pipe works well) at the mid-point of the rope to take up any slack as the water level drops. The weight should be light enough so the aerator can rise as the water level rises. This can also help hide ropes by sinking them further below the surface.

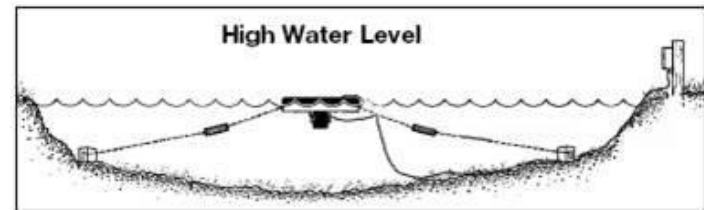
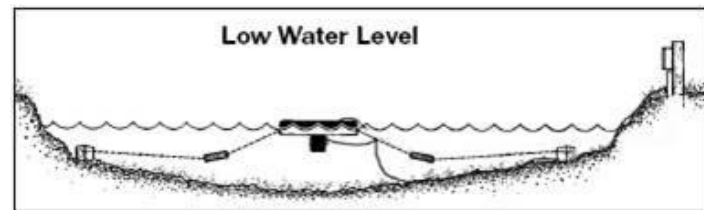
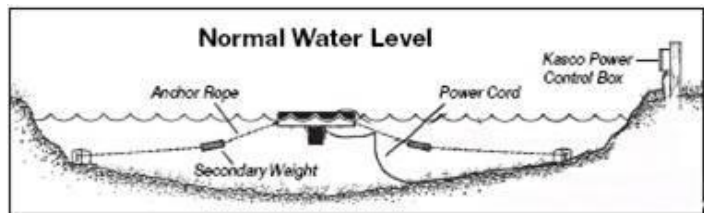
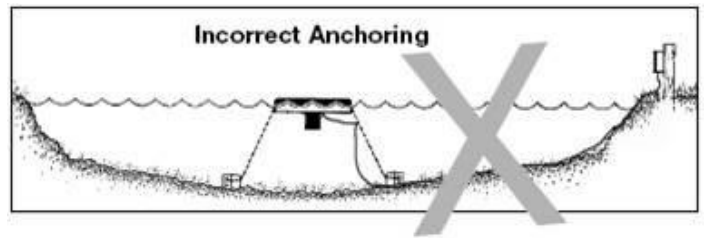
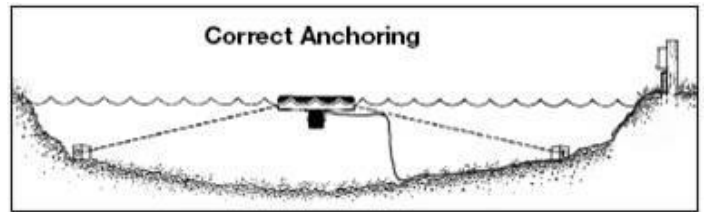

Control Panel Installation

1. Inspect the panel for any damage and any components that may have loosened during shipping. Control panel must be installed a minimum of 5ft (3m in Canada) from the inside wall of the pond, unless separated from the body of water by a fence wall, or other permanent barrier that will make the unit inaccessible to persons in the water. Install the control panel to a post structure, side of a building, or other reliable means. This structure must support the panel and prevent movement/flexing of the panel. Use #10 x 1" or longer screws in the mounting points of the control panel to secure to the post structure. NOTE: The control panel must be hung upright to be waterproof. It is also advised to mount the panel out of direct sunlight if possible by mounting the panel in a North direction. Also, mount the panel above the potential flood plain to prevent water entry during a possible flood event.
2. Set Timer in the control panel to desired ON and OFF times per the Instructions for each specific timer.
3. **Follow all local and national electrical codes for this installation and Consult a qualified electrician or service person if needed.**
 - a. (For 120V Installations) Plug the aerator cord into the C-25 outlet labeled "UNIT". If lights are included, plug the Transformer cord into the C-25 outlet labeled "LIGHT". Now you are ready to plug the C-25 into the 120V power supply on the post and ENJOY YOUR NEW KASCO AERATOR!
 - b. (For 240V Installations – 3400H, 4400H) All electrical connections to this panel must be made with proper strain relief cord grip fittings or with conduit connections as required by local and national electric codes. The bottom of the enclosure is reserved for field installation of these connections.
 - i. *C85 / C95 non-metallic control panel:* Incoming power connection: (Power feed) This control panel requires a 240V or 208V - 4 wire service (L1, L2, N, & G) and must be fed with a power circuit protected by a circuit breaker or a fused disconnect switch to provide circuit protection and a disconnection means. C-85 panel requires at least a 30amp protected circuit feeding the panel. C-95 panel requires at least a 40amp protected circuit feeding the panel. Connect your power feed as detailed in the wiring diagram provided with this panel. L1 connects to Terminal #1 L2 connects to Terminal #2 N connects to Terminal N G connects to Terminal GROUND - located on chassis plate Be sure to provide adequately sized power conductors to prevent excessive voltage drop. Consult with your electrician to properly size power feed conductors. Use copper conductors only. Aerator power cord connection: Your aerator (pump) will be provided with a flexible power cord for connection to this control panel. If the power cord has a plug, you will need to cut it off. The power cord conductors (black, white, green) will need to be stripped back 1/2". The outer black jacket should be stripped back at least 3inches. Follow the connection diagram for terminating these three wires to the terminal blocks in the control panel. Black connects to Terminal #4, White connects to Terminal #5, Green connects to Terminal G.
 1. This control panel requires a hardwire connection for the light kit(s). To connect the light kit(s) you will need to cut off the power cord plug that is molded to the light kit power cord. Strip back the black outer jacket of the light kit power cord at least 3 inches to reveal the three internal wires of the power cord. (black, white, and green conductors). These three wires will need to be stripped back 1/2". Follow the connection diagram for terminating these three wires to the terminal blocks in the control panel. Light kit connections: Black connects to Terminal #6, White connects to Terminal #7, Green connects to Terminal G.
4. Test the GFCB with the test button now and every 30 days. If lights are installed, they can now be installed per Instructions included with the lights. Once completed, power can be restored to the panel. Record the following data while the Aerator is operating in the water under load:

Voltage:

L1-L2 _____

L1-N _____

L2-N _____

Amperage:

L1 _____

L2 _____

Date installed ____/____/____

Any unauthorized modifications to this control panel will void the UL listing and the Kasco warranty.

C-25 Timer Control Instructions

Portable Timer with Ground Fault Interrupter

IMPORTANT

This portable timer is designed for CONTROLLING the connected equipment only. Unplug timer before servicing the unit or the equipment it controls. For maximum protection against electrical shock hazard, perform test procedure on G.F.C.I. at least once a month. Mount at least 5 ft. from open water.

G.F.C.I. TEST PROCEDURE

The G.F.C.I. should be checked every month to make sure that it is operating properly. Just follow the simple instructions below. It is recommended to maintain a maintenance diary of your monthly safety check.

1. Push TEST button, RESET button should pop out from inner surface. This should result in power being OFF at the outlet protected by the G.F.C.I. Verify by plugging a test lamp into the outlet. Be sure the timer is in the ON position.
2. If the G.F.C.I. tests okay, restore power by pushing the RESET button back in. THE RESET BUTTON MUST BE PUSHED FIRMLY AND FULLY INTO PLACE UNTIL IT LOCKS AND RE-MAINS DEPRESSED AFTER PRESSURE HAS BEEN REMOVED.

DANGER: IF RESET BUTTON DOES NOT POP OUT, IF TEST LAMP REMAINS LIT WHEN RESET BUTTON DOES POP OUT, OR IF THE G.F.C.I. FAILS TO RESET PROPERLY, DO NOT USE TIMER! CONTACT A QUALIFIED SERVICE TECHNICIAN!

Failure to use the C-25 with Kasco Fountains will void the warranty and cause the Fountain to not be listed to UL and CSA standards via ETL.

UNDER NO CIRCUMSTANCES SHOULD ANYONE ENTER THE WATER WHEN A UNIT IS IN OPERATION!

TIMER-OPERATION INSTRUCTIONS

C-25 Control Box will turn the aerator/fountain ON & OFF with the TIMER. Kasco lights will turn ON with the PHOTO EYE and OFF with TIMER. C-25 Control Box is to be used with Kasco Approved Lights ONLY!

- See Control panel label for instructions to set the timer
- Plug aerator/fountain cord into the RIGHT hand outlet (labeled UNIT).
- Plug transformer light cord into LEFT hand outlet (labeled LIGHT).

C85 / C95 non-metallic Control Panel Timer

TIME CLOCK SETTING

To set the current time, turn the inner dial clockwise. Do not set the time by rotating "outer" dial. Turn the minute hand or small plastic inner dial clockwise until the time of day on the outer dial is aligned with the triangle marker on the inner dial (two o'clock position). Example for 10:00 AM: Turn the minute hand clockwise until 10:00 AM is aligned with the triangle on the inner dial. The hour and the minute dial will show exactly 10:00.

PROGRAMMING

The 24-hour dial has quarter-hour divisions and AM/PM indications. The time switch is programmed by pushing the captive trippers to the outer ring position for the entire period that the aerator is to be turned "ON," i.e. 15min for each tripper on the 24-hour dial. When the tripper is pushed to the inside, the switch is in the "OFF" position.

PROGRAMMING WITH MANUAL OVERRIDE SWITCH

Your Timer may have a 3-way manual switch or a 2-way manual switch.

AUTOMATIC MODE In order to operate the time clock in the automatic mode, the manual switch must be in the automatic position- see diagram.

MANUAL MODE For the 3-way switch, with the manual override switch in the lower position, marked "O", the time clock output will remain Permanently OFF. In the upper position, marked "I", the time clock output will remain permanently ON. For the 2-way switch, with the manual override switch in the lower position, marked "ON" the time clock output will remain permanently ON.

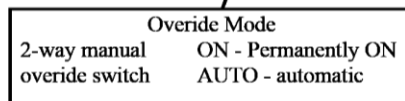
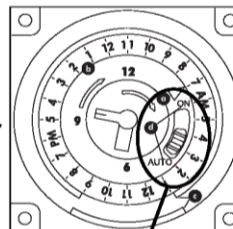
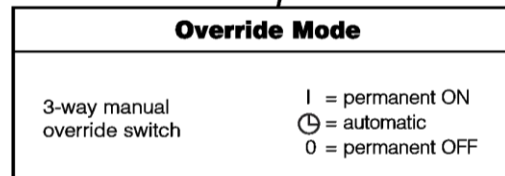
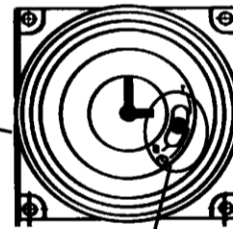
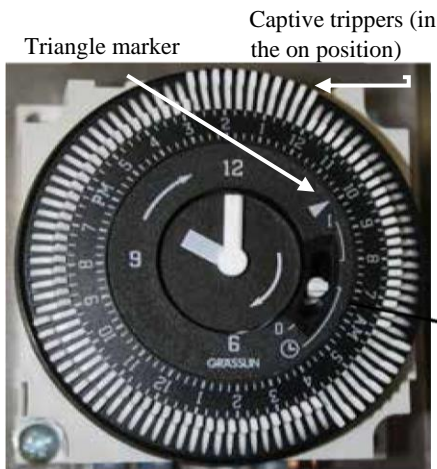

2400VFX, 3400VFX, 3400HVFX, 4400VFX, 4400HVFX
REPLACEMENT PARTS

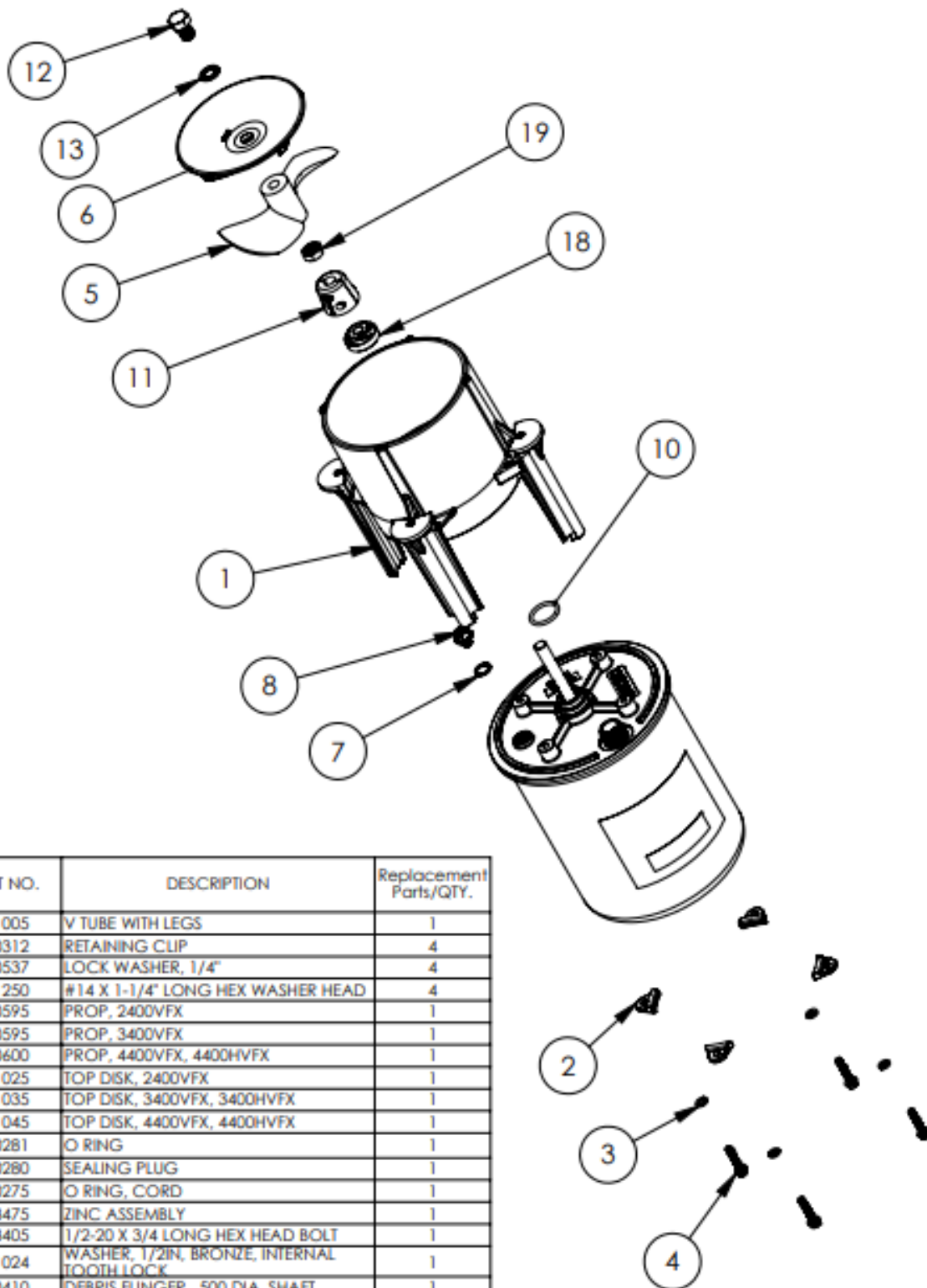

ITEM NO.	PART NO.	DESCRIPTION	Replacement Parts/QTY.
1	241005	V TUBE WITH LEGS	1
2	140312	RETAINING CLIP	4
3	840537	LOCK WASHER, 1/4"	4
4	251250	#14 X 1-1/4" LONG HEX WASHER HEAD	4
5A	240595	PROP, 2400VFX	1
5B	340595	PROP, 3400VFX	1
5C	440600	PROP, 4400VFX, 4400HVFX	1
6A	241025	TOP DISK, 2400VFX	1
6B	241035	TOP DISK, 3400VFX, 3400HVFX	1
6C	241045	TOP DISK, 4400VFX, 4400HVFX	1
7	990281	O RING	1
8	990280	SEALING PLUG	1
10	990275	O RING, CORD	1
11	243475	ZINC ASSEMBLY	1
12	243405	1/2-20 X 3/4 LONG HEX HEAD BOLT	1
13	241024	WASHER, 1/2IN, BRONZE, INTERNAL TOOTH LOCK	1
18	990410	DEBRIS FLINGER, .500 DIA. SHAFT	1
19	342058	1/2-20 JAM NUT	1

Maintenance Recommendations

**** Under No Circumstances should anyone enter the water while a aerator is operating. ** ** Please keep the original box for maintenance shipping. ****

The following maintenance procedures can be utilized to ensure many years of quality performance from your Kasco aerator and reduce the need for more costly repair work.

PROPER INSTALLATION: Proper installation of Kasco equipment will include a power source with ground fault interruption (GFI). For aerator models, the C-25 control (120V) or C-85 (240/208V) included with the unit have built-in ground fault interruption that is sufficient. Ground fault interrupters are a safety feature that can also alert you to electrical leaks in the equipment. It is extremely important to test the GFI upon installation, each reinstallation, and monthly thereafter to ensure proper operation. If you have repeat, consistent trips on your ground fault, the equipment should be disconnected and removed from the water. The power cord should be inspected for damage and you should call Kasco Marine at 715262-4488 for further instructions or email Kasco at returns@kascomarine.com.

OBSERVATION: Operating equipment should be observed on a regular basis (daily, if possible) for any reduction or variation in performance. If a change in performance is observed, the equipment should be disconnected from power and inspected for any material that may have clogged the system or wrapped around the shaft of the motor, especially plastic bags and fishing line. Even though Kasco Aerators and aerators are among the most clog-resistant on the market, it is impossible to protect against all items that can clog equipment and still maintain a flow of water. These materials can be very damaging to the equipment under continued operation and must be removed as soon as possible. **ALWAYS UNPLUG THE UNIT BEFORE ATTEMPTING TO REMOVE CLOGS.**

WINTER STORAGE: In regions where there is significant freezing in the wintertime, the aerators should be removed from the water to protect them from the expansion pressure of the ice. In many areas, aerators will keep some amount of ice open through the winter.

However, when the water is thrust into the air, it is exposed to the colder air temperatures longer and can actually make ice thicker on the pond/lake. Storage over winter is best in a location that is out of the sun and cool, but above 32°F. When storing units during the offseason, it is important to store them upside down if

they are going to be sitting for long periods of time. Units that sit upright on a shelf for many months, or even years have a greater likelihood of seals drying out. Storing upside down will ensure oil is lubricating the seals and prevent drying.

CLEANING: Aerators should be removed from the water at least once per year (at the end of the season in cold climates) to clean the exterior of the system, especially the stainless steel motor housing (can). The motor housing is the surface that dissipates heat into the water and any algae, calcium, etc. build-up will become an insulator that blocks heat transfer. In warmer regions it is recommended that the motor is removed and cleaned at least two to three times per year depending on conditions. In most cases a power washer will be sufficient if the unit and algae are still wet.

SEAL AND OIL REPLACEMENT: This is a sealed motor assembly and seals will wear out over time (similar to brake pads on a car). Replacement of the seals and a change of oil after three years may add longevity to the operation of the motor, saving you the cost of more expensive repairs. In warmer climates where the aerator runs most or all of the year, it is a good idea to replace seals more regularly than you would need to in colder climates where the unit is removed from the water for several months.

ZINC ANODE: A Sacrificial Zinc Anode is supplied on the shaft of all VFX Model aerators for protection of the equipment from corrosion and electrolysis. The zinc anode should be updated (replaced) if reduced to half the original size or if white in color. Corrosion from electrolysis is more commonly associated with saltwater or brackish water, but as a matter of precaution, it is important to periodically check the zinc anode in all installations (at least every two to three months).

Seal replacement and all other repair services should be performed by Kasco Marine or a Kasco trained Authorized Repair Center. Any alterations or changes made to Kasco units by an unauthorized source will void the warranty. This includes tampering with the unit, power cord, and/or control box. Please contact Kasco Marine, Inc. at 715-262-4488 for your nearest Authorized Repair Center.

Warranty Policy

Warranty Period:

Models: 2400VFX, 3400(H)VFX, 4400(H)VFX

- 2 years

Models: 8400VFX, 2.3(H)VFX, 5.1VFX,

5.3(H)VFX - 3 years

Kasco® Marine, Inc. warrants this aerator to be free from defects in material or workmanship (except for the ropes, power cord, and propeller) under normal use and service. The Kasco Marine, Inc. obligation under this warranty is limited to replacing or repairing free of charge any defective part within the warranty period from the date of shipment. Customer shall pay shipping charges for returning the unit to Kasco or an Authorized Repair Center.

THIS WARRANTY IS IN LIEU OF ANY OTHER WARRANTIES, EXPRESSED OR IMPLIED, AND ANY OTHER OBLIGATION OR LIABILITY WHATEVER ON THE PART OF KASCO MARINE, INC. AND IN NO EVENT SHALL KASCO MARINE, INC. BE LIABLE FOR ANY SPECIAL OR CONSEQUENTIAL DAMAGES.

Warranty is void if:

- The aerator is not maintained properly according to the Maintenance Recommendations supplied in this Owners Manual.
- The aerator is returned for repair without the power cord or if the unit, control box, or power cord are altered in any way from original shipment. Cuts in the power cord are not covered under warranty.
- The aerator is damaged by unauthorized tampering.
- The Sacrificial Zinc Anode around the propeller shaft shows significant deterioration. (The Anode must be inspected periodically and replaced if necessary.)

Warranty Claim Procedure:

The best method for establishing warranty period is by keeping your original receipt. Also register the aerator online at: www.kascomarine.com

Once the warranty coverage has been established, the unit may be sent to any Kasco Authorized Repair Center for evaluation and repair. Please call Kasco Marine at 715-262-4488 prior to shipping.

Kasco Marine, Inc. 800
Deere Rd.
Prescott, WI 54021 Attn:
Repairs

Or call Kasco Marine at 715-262-4488 to locate your nearest Authorized Repair Center. You can also email Kasco at returns@kascomarine.com

Note: Only complete motor assemblies will be accepted for warranty repair. The power cord and all other components must be returned with the motor as originally assembled. Any missing parts will be replaced at the customer's expense and, if determined to have caused the failure, could void the entire warranty. Some parts are essential for structural support during shipping and others, such as the power cord, are essential to properly diagnose potential causes of failure. It is not necessary to return the control box or float with the motor assembly.

Please include the Repair Form received from Kasco Marine or your local distributor with the shipment. If no Repair Form is available, include your name and physical address for return delivery of the repaired unit and a daytime phone number and/or e-mail address for correspondence regarding the warranty claim.

Any expedited shipping method for the return of the unit is at the customer's expense. Kasco Marine will return units repaired under warranty at our expense via ground freight within the continental United States.

Other Repairs:

Most failed equipment can be repaired at substantially lower costs than replacement with new. Please ship according to the instructions in the previous section. Again, it is best to call ahead for a Return Authorization Number and/or Repair Form so we know the repair is coming.

Kasco Marine does estimates on repairs at the request of the customer. The request for estimate should be included in the letter that accompanies the returned unit and must include a daytime phone number and/or e-mail address. Estimate options are as follows:

We will contact the customer with a total after the unit has been evaluated, but before the work is performed. We will repair the unit only if repair costs are under a stated dollar amount. Example: "Please repair if total is under \$150.00 before shipping charges."

All estimates that are rejected for repair will be destroyed unless otherwise directed by the customer. If the customer would like the unit returned, the unit will be restored as closely as possible to the condition in which it was received and shipped at the customer's expense for shipping and handling charges.

Billing:

All non-warranty repairs will be returned to the customer prepaid with Visa or Mastercard or shipped C.O.D. with C.O.D. charges unless otherwise directed. Kasco Marine will contact for credit card information upon completion of the estimate at the customer's request.

All other warranty and repair inquiries should be directed to Kasco Marine, Inc. at 715-262-4488 or returns@kascomarine.com

Troubleshooting Tips

Below are some helpful troubleshooting tips. If a problem occurs, please double check the assembly and installation instructions as well as the instructions for the proper control panel. More troubleshooting tips can be found at www.kascomarine.com (under the technical tab)

"My Aerator trips the ground fault interrupter in the C-25, C-85, or C-95."

This is the most common symptom of several possible problems. To correctly diagnose the problem, you will need to collect more information. A Ground Fault Interrupter (GFI) breaker that trips can indicate an electrical service problem, water contamination in the unit and/or cord, bad breaker, control box problems, motor problems, etc. Try to find out the answers to these questions before you contact Kasco to narrow down the problem.

- How long does it take to trip the breaker?
- Does it always take the same amount of time to trip?
- How many times has it tripped?
- Has there been any electrical problems in the area recently?

"My Aerator seems to run slowly."

This can also be a symptom of several possible problems. There could be an electrical problem where the unit is not getting the proper voltage. This could also indicate a problem with the motor of the unit, which needs to be looked at by an Authorized Repair Center. Check that the unit is receiving the proper voltage, and, if so, contact Kasco for further steps.

"My Aerator hums, but will not start. When I spin the prop with a stick, it starts up." (single phase units only)

This indicated a problem with the Starting Capacitor. Each Kasco aerator is equipped with a Starting Capacitor to get the unit going when it is first plugged in. If it is

operating, but not spinning and can be started by spinning the prop with a stick, the Starting capacitor needs to be replaced by an Authorized Repair Center.

"My Aerator turns itself off and back on without the timer and without tripping the GFI breaker." (single phase units only)

Each Kasco aerator has a Thermal Overload built in that will turn the unit off when it overheats. Once the unit has cooled down, it will start back up. If you are noticing these symptoms, the unit should be unplugged immediately because the Thermal Overload will continue to turn on and off until it burns out and damages the motor. The unit should be unplugged and taken out of the water to find the cause of the problem. The problem could be one of many, such as, low water levels, build-up on the unit to prevent heat dissipation, something inhibiting the free rotation of the shaft, etc. If something is caught in the unit or there is a build-up of algae, calcium or organic matter on the unit, remove the debris and, if caught early enough, the unit should be fine. Contact a Kasco representative before restarting the unit.

"My Aerator flow seems to fluctuate and/or be less than usual."

This can occur because of a few different reasons. Most of the time, this symptom is caused from unit being clogged with debris. A mat of weeds, many leaves, plastic bags, etc. can clog up the unit and cause it to be starved of water. If the unit does not have the proper amount of water, the flow or pattern will fluctuate up and down and look sporadic. If you are seeing these symptoms, unplug the unit and clean away the debris that is clogging up the screen. Another possibility if these symptoms are noticed, is a chipped or damaged prop that is causing the unit to wobble and not pump properly. When the unit is unplugged, check the prop for damages and replace if damage is found.

"The GFI breaker trips randomly and sporadically. Sometimes it is a few hours of operation, other times it can be days or weeks."

This is referred to as a Nuisance Trip. This usually occurs where the unit is installed a great distance from the initial electric service on the property where the ground stake is placed. It is caused by either induced current in the ground wire or a base voltage difference due to soil pH levels. To resolve the problem, contact an electrician and install a local grounding stake. This may eliminate the induced current and any base voltage differences. This problem can also be caused by a bad breaker or receptacle or having unbalanced incoming voltage lines.



800 Deere Rd

Prescott, WI 54021

Phone: 715-262-4488 Fax: 715-262-4487

www.Kascomarine.com Sales@kascomarine.com

Repair Contact Form

- ❖ Kasco requires all Repairs sent in **MUST** be accompanied by this form and marked to Repairs attention. (ex. Attn: Repairs)
- ❖ Repairs returned should include upper pump housing or wire basket for Aerators and De-Icers. These parts protect the motor during shipping.
- ❖ Kasco is **NOT** responsible for shipping damage accrued in return shipment.
- ❖ It is the responsibility of customer to ship and pay freight to Kasco.
- ❖ Do not ship float or control panel with unit, unless otherwise instructed
- ❖ **A fee of \$60 per hour will be assessed for cleaning excessively dirty units and float disassembly**
- ❖ Refer to the Owner's manual for easy-to-follow troubleshooting rule out site issue.

Note: Contact Information Should be that of the person or company to contact for repair.

Company	First Name	Last Name	
Address	City	State	
Zip code	Phone #	Alternate Phone #	
Email Address	Preferred method of contact (Circle)		Purchase order #
	Phone	Email	
Submersible Pump Information (Complete if sending unit)	Light kit Information (complete if sending lights)	Parts Included (For office use)	
Model #	Model #	Unit	<input type="checkbox"/>
Serial #	Serial #	Cord	<input type="checkbox"/>
Cord Length:	Cord Length:	Light Kit	<input type="checkbox"/>
Purchased from:	Purchased From	Float	<input type="checkbox"/>
Purchase Date:	Purchase Date:	Control Panel	<input type="checkbox"/>

Additional notes for technician.

Registration Information

Fill in the information below and keep for your records.

Model # (Ex. 5.1VX) _____

Serial # (Ex. 5101VX511725) _____

Purchase Date: _____

Purchased From: _____

Registration Date: _____