

# Swan | activair



## 20L Dehumidifier

Model: SH16810N

Help line

**0333 220 6050**



We love  
what we do



We're proud  
of our quality



## IMPORTANT INFORMATION - RETAIN FOR FUTURE USE

- When using the unit, please observe the following safety precautions:
- Unplug the power supply cord before cleaning or storage.
- The appliance can be used indoors but not in laundry rooms.
- Do not set the unit close to heat-generating devices or near flammable and dangerous materials.
- Never put your fingers or objects into the intake or discharge ducts.
- Do not sit or stand on the unit.
- Discard water that has collected in the tank as required
- Do not operate the dehumidifier in a closed area such as inside a closet, as it may cause a fire
- Do not sue the unit near edible items, objects of art, or scientific materials
- Install drain piping at a downhill grade to make sure that condensed water can be drained continuously.
- If the power supply cord is damaged it must be replaced by the manufacture or a similarly qualified person in order to avoid a hazard.
- The appliance must be positioned so that the plug is accessible.
- Please keep a distance 20 cm around unit and the wall or other objects to ensure air circulation.
- The appliance shall be installed in accordance with local national wire regulations.
- The appliance cannot be used in public transportation.
- This appliance can be used by children aged from 8 years and above if they have been given supervision or instruction concerning use of the appliance in a safe way and if they understand the hazards involved. Cleaning and user



## IMPORTANT INFORMATION - RETAIN FOR FUTURE USE

maintenance shall not be made by children unless they are older than 8 and supervised. Keep the appliance and its cord out of reach of children aged less than 8 years.

- Appliances that are obviously damaged must not be operated.
- **WARNING:** Do not use means to accelerate the defrosting process or to clean, other than those recommended by the manufacturer.
- The appliance shall be stored in a room without continuously operating ignition sources (for example: open flames, an operating gas appliance or an operating electric heater).
- Do not pierce or burn.
- Be aware that refrigerants may not contain an odour.
- Appliance shall be installed, operated and stored in a room with a floor area larger than 4 square metres.
- Servicing shall be performed only as recommended by the manufacturer.
- The appliance shall be stored so as to prevent mechanical damage from occurring.
- Any person who is involved with working on or breaking into a refrigerant circuit should hold a current valid certificate from an industry-accredited assessment authority, which authorizes their competence to handle refrigerants safely in accordance with an industry recognized assessment specification.
- Servicing shall only be performed as recommended by the equipment manufacturer. Maintenance and repair requiring the assistance of other skilled personnel shall be carried out under the supervision of the person competent in the use of flammable refrigerants.







## IMPORTANT INFORMATION - RETAIN FOR FUTURE USE

- Appliance is filled with flammable gas R290.
- Any repairs you need, contact the nearest authorised Service Centre.



Caution: Risk of fire



 <p>Caution: Risk of fire</p>	<p><b>The refrigerant gas</b> contained in the circuit of this device is isopropane (R290), low pollutant but flammable gas.</p> <p>When transporting and installing the unit, take care not to damage any part of the refrigerant circuit.</p>		<p><b>User Manual.</b> Identify the location where the user manual is stored or identify information about the instructions for use. Indicate that the operating instructions must be taken into account when using the device or control near the location of the symbol</p>
	<p><b>Read the instructions for use:</b></p> <p>Read and observe the safety instructions before using the device. Keep this leaflet and inform potential users as it contains important information.</p>		<p><b>Service manual;</b> Read the technical manual: To indicate that a machine or equipment requires service. To indicate that the service manual should be consulted. To identify the location where the service manual is stored.</p>



## TECHNICAL DATA

Description: 20L Dehumidifier

Model: SH16810N

Input Voltage: 220-240V ~ 50Hz

Power: 310 Watts

Water tank capacity: 4 Litres

Refrigerant/charge: R290 / 80g



The dehumidification capacity is rated at a room temperature of 30C with a relative humidity of 80%.

The operational temperature is in the range of 5 - 35C and max relative humidity of 80%. If the room temperature is outside of this range, the unit will not operate normally.

### Low Temperature Operation with Automatic Defrost

When the unit is running in a room temp. between 5 - 12C, it will stop to defrost for every 30 minutes

When the unit is running in a room temp between 12 - 20C, it will stop to defrost for every 45 minutes

## CLEARANCE

Maintain the minimum clearance around the dehumidifier when the unit is operating as shown in the drawing.

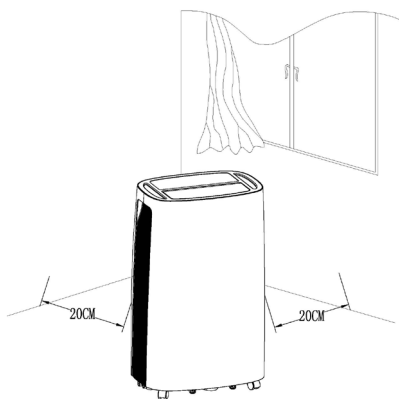



## GET TO KNOW YOUR PRODUCT

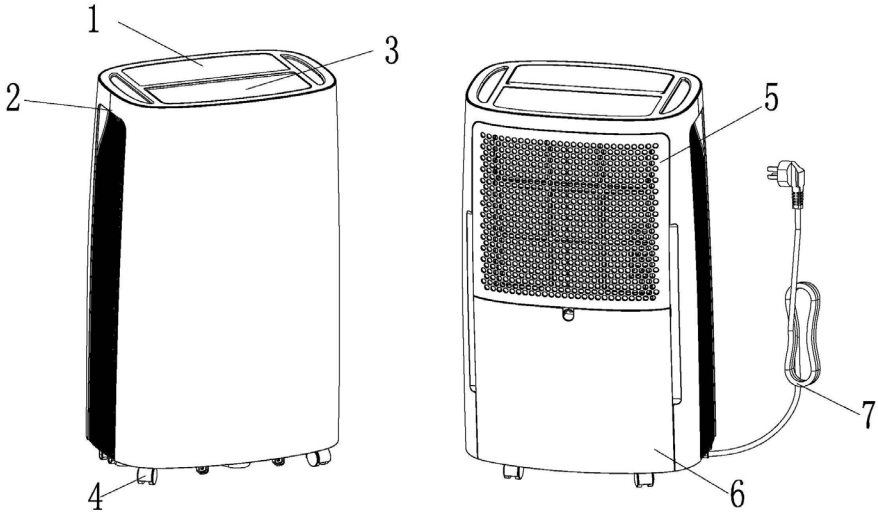

1. Control panel
2. Handle
3. Wind deflector
4. Castor

5. Filter compartment
6. Water tank
7. Power cord

## CONTROL PANEL





## OPERATION



The Digital display has numerous functions:

1. When the unit is plugged in, it will indicate the room humidity level.
2. When you set the humidity, it will indicate the humidity that you have selected
3. When you program the time for the unit to turn on and off, it will show the hours.
4. When the room humidity is lower than 35%, it will show "35"
5. When the room humidity is higher than 95%, it will show "95"

### OPERATING INSTRUCTIONS

The buzzer will sound several times when the unit is powered on. The LED will show the room humidity for 3 seconds, then it will automatically turn off.

1. **Turn on/off**, press:

2. **Humidity setting**, press: Then press: or to select humidity level. 40% to 80%, in 5%, increments. The LED display will flash when adjusting. Stop pressing for 5 seconds, it will return to normal display. The default value of humidity is 55%.

3. **Fan speed setting**, press: Press repeatedly to cycle through the fan speeds. The corresponding LED light will illuminate.

4. **Swing setting**, press: After the machine has started the louvres will swing back and forth. Press again to stop.

5. **Timer setting**, press: when the unit is stopped, then press or to set **start time**. Start time range is between 1 - 24 hours.

To set **run time**: With machine running press then press or to set how long the unit will run for before it switches itself off. Run time range is 1 - 24 hours.

**Please note:** if the tank gets full during the selected run time, the unit will stop, a buzzer will sound and the tank full indicator will illuminate.



## OPERATION

### Emptying the Drainage Tank

1. Lightly press on the sides of the tank with both hands and pull the tank out gently.

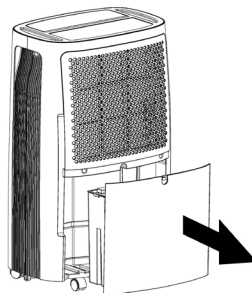

2. Discard the collected water.



3. **If the drainage tank is dirty, wash it with cold or lukewarm water.** Do not use detergent, scouring pads, chemically treated dust cloths, gasoline, benzene, thinner, or other solvents, as these can scratch and damage the tank and cause water leakage

4. **When replacing the drainage tank,** press the tank firmly into place with both hands. If the tank is not positioned properly, the "TANK FULL" sensor will be activated, and the dehumidifier will not operate.

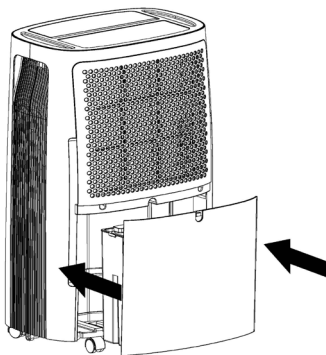





## OPERATION

### Continuous Water Drainage

The unit features a continuous drainage port. Using a plastic pipe not included (inner diameter of 10mm) inserts into the drain hole (on intermediate plate), site the other end of the pipe to a permanent drain.

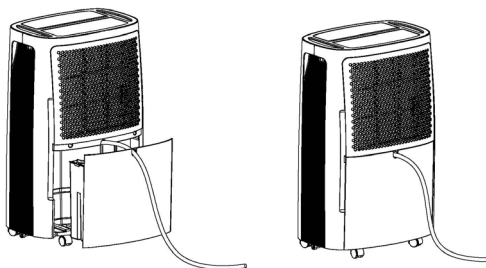

## CLEANING & MAINTENANCE

Always unplug the appliance and keep it away from any socket before cleaning.

- To clean the outer surface of the appliance, use a lightly damp cloth. Then, dry it thoroughly with a soft, dry cloth before using again.
- Do not use any cleaning or chemical products of any kind. Do not let water enter the openings on the dehumidifier.
- When the appliance is not being used for prolonged periods, ensure that the filter and water tank is cleaned well. **Don't allow water to sit in the appliance for long periods!**
- Unplug from the socket and store in its packaging.

### To clean the air filter:

- Open the inlet grille first and remove the air filter.
- Run a vacuum cleaner lightly over the surface of the air filter to remove dirt. If the air filter is exceptionally dirty, wash it with warm water and a mild cleanser and dry thoroughly.

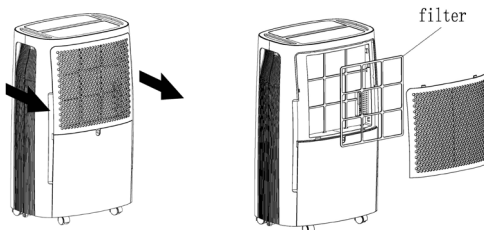

**To re-fit**, offer the filter up to the front of the humidifier and fit the grille over it. Then snap into place.





## TROUBLE SHOOTING

Problem	Possible cause	Solution
The unit doesn't operate	Check power cord	Connect power cord
	Is the tank full indicator blinking? Is tank properly fitted?	Empty tank. Refit tank correctly.
	Is temperature of the room above 35C or below 5C?	Unit cannot run in these temperatures
Dehumidifying function doesn't work.	Is the air filter clogged?	Clean the air filter
	Is the intake duct or discharge duct obstructed?	Remove the obstruction
No air is discharged	Is the air filter clogged?	Clean the air filter
Operation is noisy	Is the unit tilted or unsteady?	Move unit to a more suitable location
	Is the air filter clogged?	Clean the air filter.



## SPARES

The following spares are available via our web site:

SH16810N01 - air filter

[www.swan-brand.co.uk](http://www.swan-brand.co.uk)



## WARRANTY

This product is guaranteed for 2 years from the date of original purchase. If any defect arises due to faulty materials or workmanship the faulty products must be returned to the place of purchase. Refunds or replacement is at the discretion of the store.

The following conditions apply:

- The product must be returned to the retailer with proof of purchase.
- The product must be installed and used in accordance with the instructions contained in this instruction guide.
- It must be used only for domestic purposes.
- It does not cover wear and tear, damage, misuse or consumable parts.
- Swan Products Ltd has limited liability for incidental or consequential loss or damage.
- This guarantee is valid in the UK and Eire Only.



## BS PLUG

The wires in the mains lead are coloured in accordance with the following code:

BLUE	NEUTRAL
BROWN	LIVE

As the colours of the wire in the mains lead of this appliance may not correspond with the colour markings identifying the terminals on your plug, proceed as follows:

The wire which is coloured BLUE must be connected to the terminal which is marked with the letter N or coloured black. The wire which is coloured BROWN must be connected to the terminal which is marked with the letter L or coloured red.

**WARNING: THIS APPLIANCE IS DOUBLE INSULATED. DO NOT CONNECT ANY WIRE TO THE EARTH PIN**



## DISPOSAL OF UNIT



Appliances bearing the symbol shown here may not be disposed of in domestic rubbish. You are required to dispose of old electrical and electronic appliances like this separately. Please visit [www.recycle-more.co.uk](http://www.recycle-more.co.uk) or [www.recyclenow.co.uk](http://www.recyclenow.co.uk) for access to information about the recycling of electrical items. Please visit [www.weeeireland.ie](http://www.weeeireland.ie) for access to information about the recycling of electrical items purchased in Ireland. The WEEE directive, introduced in August 2006, states that all electrical items must be recycled, rather than taken to landfill. Please arrange to take this appliance to your local Civic Amenity site for recycling, once it has reached the end of its life.



[www.swan-brand.co.uk](http://www.swan-brand.co.uk)



Scan this QR code  
to hear about  
our story



We love  
what we do



we're proud  
of our quality



Find us on Facebook

\* on selected products

Copyright © Swan Products Ltd.  
PO Box 3117, Stoke-on-Trent ST4 9GD

