



800W
MICROWAVE
INSTRUCTION MANUAL



V1.0

SM22030CELN
HELPLINE: 0333 220 6050

Officially Licensed
Product



IMPORTANT SAFEGUARDS

Please retain these instructions for future use.

INSTALLATION

- 1.** Read all instructions before using.
- 2.** Make sure the voltage in your living area corresponds to the one shown on the rating label of the appliance, and the wall socket is properly earthed.
- 3.** Take out all the packing. If there is a safe film over the oven, tear it off before use. Check carefully for damage. If any, immediately notify dealer or send to the manufacturer's service centre.
- 4.** Microwave ovens must always be placed in dry and non-corrosive environments and kept away from heat and humidity, such as gas burners or water tanks.
- 5.** To ensure sufficient ventilation, the distance of the back of microwave to the wall should be at least 10cm, the side to the wall should be at least 5cm, the free distance above the top surface at least 20cm, the distance of the microwave to the ground should be at least 85cm.
- 6.** The microwave oven should always be positioned far from TVs, radios or antennas as picture disturbance or noise may occur.
- 7.** The appliance must be positioned so that the plug is accessible, and must ensure a good earth connection.
- 8.** The microwave oven must be operated with the door closed.
- 9.** The microwave oven must not be placed in a cabinet. The microwave oven is intended to be used freestanding.
- 10.** The back of the oven must be placed against a wall.
- 11.** Do not use outdoors.



IMPORTANT SAFEGUARDS

When using this microwave oven some basic safety precautions must be followed.

1. To reduce the risk of fire:

- Do NOT use the oven to heat empty plates or utensils. This will damage the microwave generator and will cause failure and risk of melting or fire.
- Do not overcook the food.
- Remove wire twist-ties from paper or plastic bags before placing bags in the oven.
- Do not heat oil or fat for deep frying as the temperature of oil cannot be controlled.
- After use, wipe the internal cavity with a damp cloth, followed by either a drying with a paper towel or leaving the door open to allow full drying. Built-up grease may cause smoke or catch fire.
- If materials inside the oven should smoke or ignite, keep oven door closed, turn oven off and disconnect the power supply.
- Close supervision is necessary when using disposable containers made from plastic, paper or other combustible material.

2. To reduce the risk of explosion and sudden boiling:

- Do not place sealed containers in the oven. Baby bottles fitted with a screw cap or teat are considered to be sealed containers.
- When boiling liquid in the oven, use a wide-mouthed container and leave to stand for about 20 seconds at the end of cooking to avoid delayed eruption of boiling liquids.
- Potatoes, sausage and chestnuts should be peeled or pierced before cooking. Eggs in their shell and whole hard-boiled eggs should not be heated in microwave ovens since they may explode, even after microwave heating has ended.



IMPORTANT SAFEGUARDS

3. Don't operate the oven further if the door or door seal is damaged, or if the oven is malfunctioning, or supply cord is damaged. Return the appliance to the nearest authorised service centre for repair and maintenance. Never try to adjust or repair the oven yourself.
4. If the supply cord is damaged, it must be replaced by the manufacturer or its service agent or a qualified technician in order to avoid a shock hazard.
5. After cooking, the container could be very hot. Use gloves to take out the food and avoid steam burns by directing steam away from the face and hands.
6. Slowly lift the furthest edges of dish cover and microwave plastic wraps and carefully open popcorn and oven cooking bags away from the face.
7. To prevent the turntable from breaking:
 - Let the turntable cool down before cleaning.
 - Do not place hot foods or utensils on the cold turntable.
 - Do not place frozen foods or utensils on the hot turntable.
8. Make sure the utensils do not touch the interior walls during cooking.
9. Wipe clean and dry the cavity after each use. Failure to do so will result in a fire risk and corrosion.
10. Only use utensils that are suitable for use in microwave ovens.
11. Do not store food or any other things inside the oven.
12. This appliance is not intended for use by young children or infirm persons without supervision.
13. Any accessories not recommended by the manufacturer may cause injuries to persons.
14. **WARNING:** Only allow children to use the oven without supervision when adequate instructions have been given so that the child is able to use the oven in a safe way and understands the hazards of improper use.
15. **WARNING:** Accessible parts may become hot during use. Young children should be kept away.



IMPORTANT SAFEGUARDS

16. Children should be supervised to ensure that they do not play with the appliance.
17. The appliance is not intended to be operated by means of an external timer or separate remote control system
18. This appliance is intended to be used in household and similar applications such as:
 - Staff kitchen areas in shops, offices and other working environments;
 - Farm houses;
 - By clients in hotels, motels and other residential environments;
 - Bed and breakfast type environments.
19. The microwave oven is intended for heating food and beverages. Drying of food or clothing and heating of warming pads, slippers, sponges, damp cloth and similar items may lead to risk of injury, ignition or fire.
20. This appliance can be used by children aged from 8 years and above and persons with reduced physical, sensory or mental capabilities or lack of experience and knowledge if they have been given supervision or instruction concerning use of the appliance in a safe way and understand the hazards involved. Children shall not play with the appliance. Cleaning and user maintenance shall not be made by children unless they are older than 8 and supervised. Keep the appliance and its cord out of reach of children less than 8 years. Cleaning and user maintenance shall not be made by children without supervision.
21. The door or the outer surface may get hot when the appliance is operating.

Household use only.



TECHNICAL DATA

Description:	800W Microwave
Model:	SM22030CELN
Capacity:	20L
Output:	800 Watts
Input Voltage:	220-240V
Frequency:	50
Input Power:	1150 Watts
Microwave Frequency:	2450MHz



WARNING!
HOT SURFACES



CAUTION!
Do not immerse in water

DOCUMENTATION

We at Swan Products Ltd declare that this product conforms to the following product legislation in accordance with the following directive(s):

- 2014/30/EU The EMC Directive (the Electromagnetic Compatibility Directive)
- 2014/35/EU. The LVD Directive (Low Voltage Directive)
- 2011-65-EU. The RoHS directive (Restriction of Hazardous Substances Directive)
- EC 1935/2004 Food Contact
- 2009/125/EC Eco Design Regulation

GET TO KNOW YOUR MICROWAVE

UTENSILS GUIDELINE

It is strongly recommended to use containers which are suitable and safe for microwave cooking. Generally speaking, the containers which are made of heat-resistant ceramic, glass or plastic are suitable for microwave cooking. **Never use metal containers** for microwave cooking and combination cooking as sparks are likely to occur.

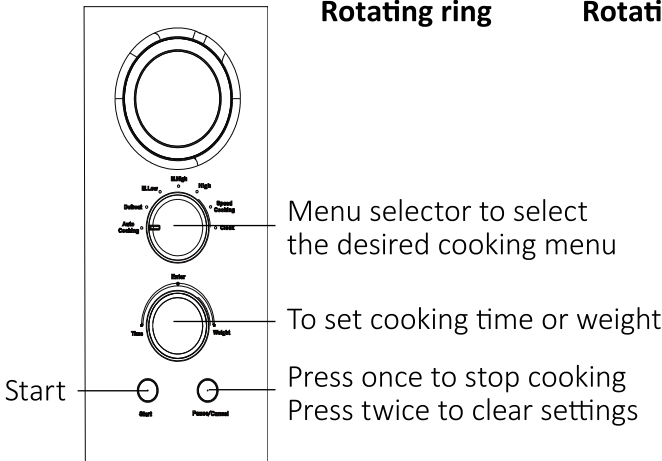
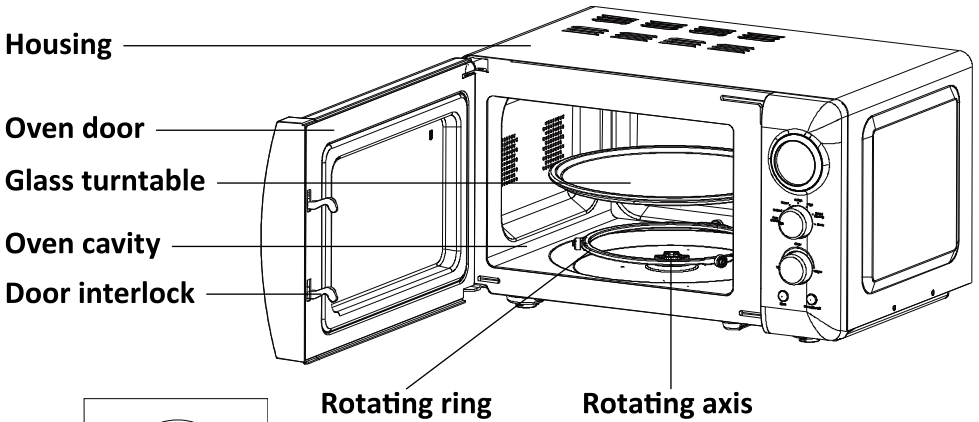

Control Panel



WARNING!

Do not remove the Waveguide cover during cleaning.

Make sure the Waveguide cover is properly in place during cooking.



HOW TO USE YOUR MICROWAVE

CAUTION!

The LED flashes 3 times when plugged into a power supply. It then shows **00:00**, prompting you to input the cooking menu and time. During setting the cooking process, it will return to standby state automatically if no entry is made within 2 minutes.

1. Auto reminder

When your preset cooking selection has finished, the LED display will show **End** and three beeps will sound, to prompt you to take out food. If you do not press **Pause/Cancel** button once or open the door or turn the **Menu Selector**, the beep will sound at an interval of 3 minutes.

2. Speed cooking

The oven will start express cooking by selecting this menu. After setting this menu by turning the **Menu Selector** dial, press the **Start** button to start cooking. Its default cooking time is 30 seconds. You can increase the cooking time by pressing the **Start** button, each press will increase the cooking time by 30 seconds, up to a maximum setting of 10 minutes.

3. Clock setting

Turning the **Menu Selector** to **Clock** enables you to input current time.

For example: to set 12:30

	Action	Display
1	Power up the oven.	00 : 00
2	Turn the Menu Selector to Clock .	00 : 00
3	Press Enter for 3 seconds to enter the clock setting.	
4	Turn Time/Weight dial to set the exact hours.	12 : 00
5	Press the Enter button once again.	12 : 00
6	Turn Time/Weight dial to set the exact minutes.	12 : 30
7	Press the Enter button once again or wait for 1 minute for the clock to operate from this setting.	



HOW TO USE YOUR MICROWAVE

MICROWAVE COOKING

This function is used for cooking and heating food. There are three selections for microwave cooking by turning the **Menu Selector**.

High power	100% Microwave power. Applicable for quick and thorough cooking
Medium high power	80% Microwave power. Applicable for medium express cooking.
Medium power	60% Microwave power. Applicable for steaming food.
Medium low power	40% Microwave power. Applicable for defrosting food.



CAUTION!

- a. The max time which can be set is 60 minutes.
- b. Never operate the oven when empty.
- c. If you turn the food during operation, press the **Start** button once and the preset cooking procedure will continue.
- d. If you intend to remove the food before the preset time, you must press the **Pause/Cancel** button once to clear the preset procedure to avoid unintended operation during next use.



HOW TO USE YOUR MICROWAVE

For example: to cook at P80 for 10 minutes

Press		Display
1	After power-up, the colon flashes.	:
2	Select the desired microwave power by pressing the Micro Power button consecutively.	80P
3	Set cooking time by turning Time/Weight dial.	10 : 00
4	Press Instant/Start button and the LED display will count down to show running time.	

CAUTION!

You may change the cooking time during cooking. It is recommended to turn or stir the food halfway through. After you turn or stir the food, press the **Start** button once to continue.

DEFROST

This function is used to defrost food, turn the **Menu Selector** to **Defrost** to carry out this function. The weight range suitable for defrosting is 0.1 kg - 2.0 kg.

For example: to defrost 0.4kg poultry

Press		Display
1	Power up the oven.	:
2	Turn the Menu Selector to Defrost .	dEF
3	Turn Time/Weight dial to set the defrost weight.	0 . 4
4	Start cooking by pressing the Start button.	5 : 16
5	Half way through the defrosting process, 3 beeps will sound to prompt you to turn the food over. Open the door and turn the food over, shielding the warm portion. Then close the door. Press Start button again to continue defrosting.	



HOW TO USE YOUR MICROWAVE

CAUTION!

- a. For even defrosting, it is necessary to turn the food over during operation.
- b. Defrosting will typically take longer than the cooking of food.
- c. If the food can be cut with a knife, the defrosting process can be considered complete.
- d. The microwave penetrates around 4cm into most food.
- e. Defrosted food should be consumed as soon as possible, it is strongly not advised to put the food back into a fridge or refreeze.

AUTO COOKING

The oven has a default cooking menu for simple operation. When the oven is in standby, turn the **Menu Selector** to **Auto Cooking**, then turn **Time/Weight** dial to select the auto cooking menu.

Choose the appropriate menu according to the food type and weight and strictly observe the directions in the following table, otherwise cooking efficiency could be effected.

Display	Kind	Weight
A-01	Popcorn	Two options (3.0 oz and 3.5 oz)
A-02	Potato	Two options (0.45 kg and 0.65 kg)
A-03	Vegetable	Five options (0.1 kg, 0.2 kg – 0.5 kg)
A-04	Meat	Six options (0.2 kg, 0.3 kg – 0.7 kg)
A-05	Fish	Six options (0.2 kg, 0.3 kg – 0.7 kg)
A-06	Chicken	Six options (0.2 kg, 0.3 kg – 0.7 kg)
A-07	Reheat	Five options (0.2 kg, 0.4 kg – 1.0 kg)



HOW TO USE YOUR MICROWAVE

A-08	Beverage	Two options (250ml and 500ml)
A-09	Rice	Five options (0.1 kg, 0.2 kg – 0.5 kg)
A-10	Pasta	Five options (0.1 kg, 0.2 kg – 0.5 kg)
A-11	Bread	Five options (0.1 kg, 0.2 kg – 0.5 kg)
A-12	Pizza	Two options (1 share and 2 share)

For example: to steam 0.4kg fish

Press		Display
1	Power up the oven.	00 : 00
2	Turn the Menu Selector to Auto Cooking .	A-01
3	Turn the Time/Weight dial to select the auto cooking menu.	A-05
4	Press Enter to confirm.	A-05
5	Turn Time/Weight dial to set the weight.	0 . 4
6	Start cooking by pressing the Start button.	10 : 00

CHILD LOCK FUNCTION

Use this feature to lock the control panel when you are cleaning or so that children can not use the oven unsupervised. All the buttons are rendered inoperable in this mode.

1. To set child lock, press and hold **Pause/Cancel** button about 3 seconds.
2. To cancel child lock, press and hold **Pause/Cancel** button about 3 seconds.



HOW TO USE YOUR MICROWAVE

COOKING TIPS

The following factors may affect the cooking result:

Food arrangement

Place thicker areas towards the outside of the dish and thinner parts towards the centre. Spread it evenly. Do not overlap if possible.

Cooking time length

Start cooking with a short time setting, check the food after the cooking time ends and extend the timing as needed. Over cooking may result in smoke and/or burning.

Cooking food evenly

Food such as chicken, hamburger or steak should be turned once during cooking. Depending on the type of food, if applicable, stir it from the outside to the centre of the dish once or twice during cooking.

Allow standing time

After the cooking time ends, leave the food in the oven for an adequate length of time, this allows it to complete its cooking cycle and cools it down in a gradual manner.

Check the food is done

Colour and hardness of food can help to determine if it is done, these include:

- Steam coming out from all parts of food, not just the edge.
- Joints of poultry can be moved easily.
- Pork or poultry shows no signs of blood.
- Fish is opaque and can be sliced easily with a fork in a gradual manner.



HOW TO USE YOUR MICROWAVE

Browning dish

When using a browning dish or self-heating container, always place a heat-resistant insulator such as a porcelain plate under it to prevent damage to the turntable and rotating ring.

Microwave safe plastic wrap

When cooking food with high fat content, do not allow the plastic wrap to come into contact with food as it may melt.

Microwave safe plastic cookware

Some microwave safe plastic cookware might not be suitable for cooking foods with high fat and sugar content. Also, the preheating time specified in the dish instruction manual must not be exceeded.



CLEANING & MAINTENANCE

The oven should be cleaned regularly and any food deposits removed.

CAUTION!

1. It is hazardous for anyone other than a competent person to carry out any service or repair operation that involves the removal of a cover which gives protection against exposure to microwave energy.
2. Remove the power cord from the wall outlet before cleaning. Do not immerse the appliance in water or other fluids when cleaning.
3. Failure to maintain the oven in a clean condition could lead to deterioration of the surface that could adversely affect the life of the appliance and possibly result in a hazardous situation.
4. The oven should be cleaned regularly and any food deposits removed.

Details for cleaning door seals, cavities and adjacent parts:

6. Never use harsh detergent, abrasive powder or sharp metal implements to clean any part of the appliance.
7. Do not remove the Waveguide cover.
8. When the microwave oven has been used for a long time, there may be some unpleasant odours existing in the oven. The following 3 methods can help to remove them:
 - a. Clean all interior surfaces with warm water and dish washing soap and fully dry.
 - b. Place a cup of water, with a tablespoon of white vinegar or lemon juice, on the turntable and operate on full power for 2-3 minutes. Leave door closed for a minimum of 15 minutes.
 - c. Wipe dry with a clean cloth or paper towel.

Wipe exterior parts with a dampened soft cloth.

Wipe clean the interior surfaces with a dampened soft cloth.

Wipe clean the Waveguide cover to remove any food splashed on it.

Turntable/rotation ring/rotation axis:

Wash with mild soapy water. Rinse with clean water and allow to dry thoroughly. The glass turntable is OK to put in the dishwasher.



SERVICING

Please check the following before calling for service:

- a. Place a glass measuring container of water (approx.150ml) in the oven and close the door securely. The oven lamp should go off if the door is closed properly. Let the oven work for 1 min.
- b. Does the oven lamp light?
- c. Does the cooling fan work? (Put your hand over the rear ventilation openings.)
- d. Does the turntable rotate? (The turntable can rotate Clockwise or counter Clockwise. This is quite normal.)
- e. Is the water inside the oven hot?

If “NO” is the answer to any of the above questions, please check your wall socket and the fuse in your meter box.

If both the wall socket and the fuse are functioning properly, contact our helpline on **0333 220 6050**.

WARNING!

If the door or door seals are damaged, the oven must not be operated until it has been repaired by a competent person.

Rusting inside the cavity

Rusting is a result of failure to dry or ventilate the cavity after use.

It can be resolved by removing all signs of rust and coating with a suitable microwave oven safe paint.



SERVICING SAFEGUARDS

CAUTION!

1. If LED displays **Err0** during working, it indicates that the sensor has been short circuited and you need replace it at the nearest repair department.
2. If LED displays **Err1** during working, it indicates that the sensor is open circuit and you need replace it at the nearest service centre.

DISPOSAL OF UNIT

Disposal instructions for Swan items in accordance with the WEEE directive. Appliances bearing the symbol shown here may not be disposed of in domestic rubbish. You are required to dispose of old electrical and electronic appliances like this separately. Please visit www.recyclemore.co.uk, or www.recyclenow.co.uk for access to information about the recycling of electrical items. The WEEE directive, introduced in August 2006, states that all electrical items must be recycled, rather than taken to landfill. Please arrange to take this appliance to your local Civic Amenity site for recycling, once it has reached the end of its life.





WARRANTY

This product is guaranteed for 2 years from the date of original purchase. If any defect arises due to faulty materials of workmanship the faulty products must be returned to the place of purchase. Refunds or replacement is at the discretion of the store.

The following conditions apply:

- The product must be returned to the retailer with proof of purchase.
- The product must be installed and used in accordance with the instructions contained in this instruction guide.
- It must be used only for domestic purposes.
- It does not cover wear and tear, damage, misuse or consumable parts.
- Swan Products Ltd has limited liability for incidental or consequential loss or damage.
- This guarantee is valid in the UK and Eire Only.



BS PLUG

The wires in the mains lead are coloured in accordance with the following code:

BLUE	NEUTRAL
BROWN	LIVE
GREEN/YELLOW	EARTH

As the colours of the wire in the mains lead of this appliance may not correspond with the colour markings identifying the terminals on your plug, proceed as follows:

The wire which is coloured BLUE must be connected to the terminal which is marked with the letter N or coloured black. The wire which is coloured BROWN must be connected to the terminal which is marked with the letter L or coloured red. The wire which is coloured GREEN/YELLOW must be connected to the terminal which is marked with the letter E (or earth symbol) and is coloured GREEN or GREEN/YELLOW.

WARNING: THIS APPLIANCE MUST BE EARTHED



PART OF THE
CELTIC FC RANGE



YOU'LL NEVER WALK ALONE



FOLLOW US ONLINE - CELTICFC

Copyright © Swan Products Ltd,
PO Box 3117, Stoke-on-Trent ST4 9GD