

# Swan | activair



## Air Purifier ECO 15

Model: SAC64010N

[www.swan-brand.co.uk/support](http://www.swan-brand.co.uk/support)



We love  
what we do



We're proud  
of our quality



### WARNING!

The product must be installed in accordance with the national wiring rules. This unit is intended for household and domestic indoor use only.

- Use the appliance in a room size corresponding to its cooling capacity.
- Do not use the appliance near gas appliances, fireplaces or flammable liquids.
- Handle the appliance with care.
- Keep your appliance about 1 meter away from any other electrical device to avoid the risk of electromagnetic interference.
- To avoid overheating, please put the appliance about 50cm away from a wall and do not cover it.
- Do not expose to direct or indirect heat sources.
- Do not use this appliance in wet area, and not to have contact with water.
- Do not submit the unit to strong shocks or vibrations.
- The plug must be easily accessible when the device is connected.
- Before connecting the appliance, check that:
  - The supply voltage is the same as the nameplate,
  - The power supply socket is suitable for the device,
  - The cable plug is adapted to the socket

The product is intended only for a socket with a mains voltage of 220-240 volts (50/60 Hz).



## IMPORTANT SAFEGUARDS

- Always remove the plug from the socket when not in use.
- Do not use the unit with a damaged cord or plug.
- The appliance should be unplugged when filling and cleaning.
- This appliance can be used by children aged from 8 years and above and persons with reduced physical, sensory or mental capabilities or lack of experience and knowledge if they have been given supervision or instruction concerning use of the appliance in a safe way and understand the hazards involved. Children shall not play with the appliance. Cleaning and user maintenance shall not be made by children without supervision.
- Never insert fingers, pencils or other objects through the grid when the appliance is running.
- This product complies with the requirements of directives 2014/35/EU (repealing Directive 73/23/EEC amended by Directive 93/68/EEC) and 2014/30/EU(repealing Directive 89/336/EEC).
- Never run the product in the presence or within reach of unsupervised children.
- If the power cord is damaged, it must be replaced by the manufacturer, its service or similarly qualified persons in order to avoid a hazard.
- User instructions should be provided with the device so that it can be used safely.
- Use the appliance on a flat surface.
- For cleaning and maintenance instructions, refer to the corresponding section.



### CAUTION

In order to prevent damage to users and other personnel and to avoid property damage, please be sure to observe the following:

- Never use liquids to clean air purifiers such as water, detergents or flammable solvents.
- When cleaning the air purifier, please disconnect the purifier from the power source. Wipe it only with a soft rag.
- The air purifiers use precision components. Please use it properly to prevent it from falling or being damaged!
- Keep the air purifiers surrounding area unobstructed. Do not cover the Air Purifier's air inlet and outlet.
- Never discard the purifier with household waste. Dispose of the purifier at a nearby official waste collection centre. Filters are classified as household rubbish.
- Do not use the unit with a damaged cord or plug.
- The appliance should be unplugged from the mains when filling and cleaning.



**Important:**

- Before using it for the first time, remove the plastic bag from the filter.
- Never obstruct the air inlets and outlets.
- Never use the appliance without the filter.
- Use on a stable, horizontal and flat surface.

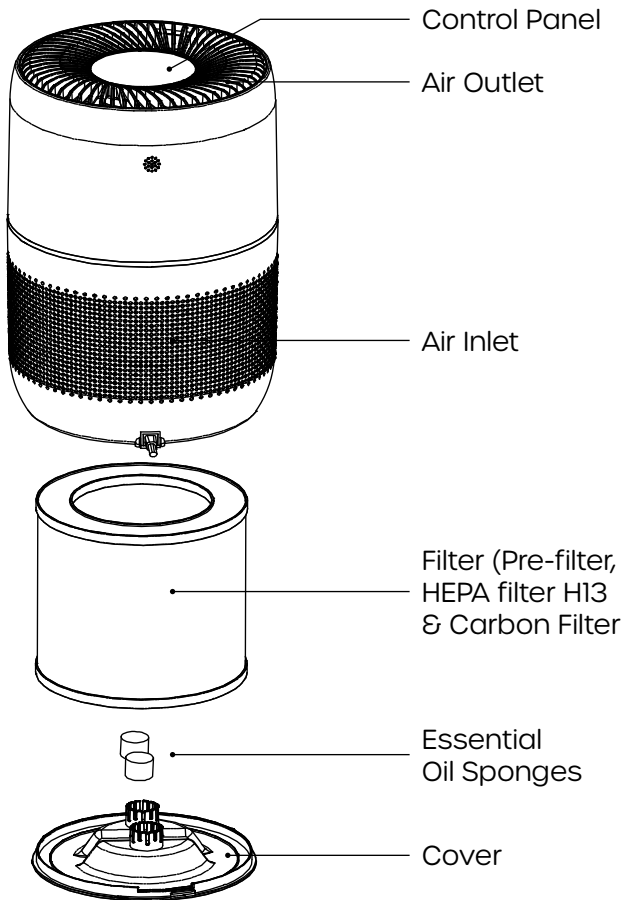







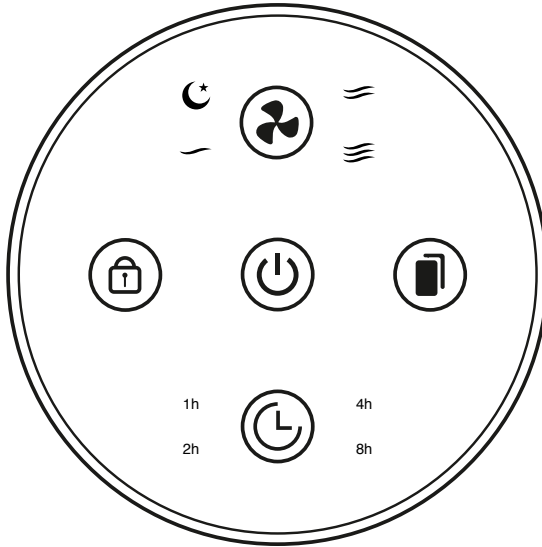



# OPERATING CHARACTERISTICS

## Control Panel



	On/Off
	Ventilation Speed Control: Sleep  → Low  Medium  → High 
	Child Lock
	Reset Filter Usage Count
	Timer 1 to 8 Hours



Before using for the first time, remove the plastic bag from the filter.

1. Filter installation

Turn the air purifier upside down, grasp the handle of the cover and turn the cover in the direction of the 'unlocked' lock  to the left.

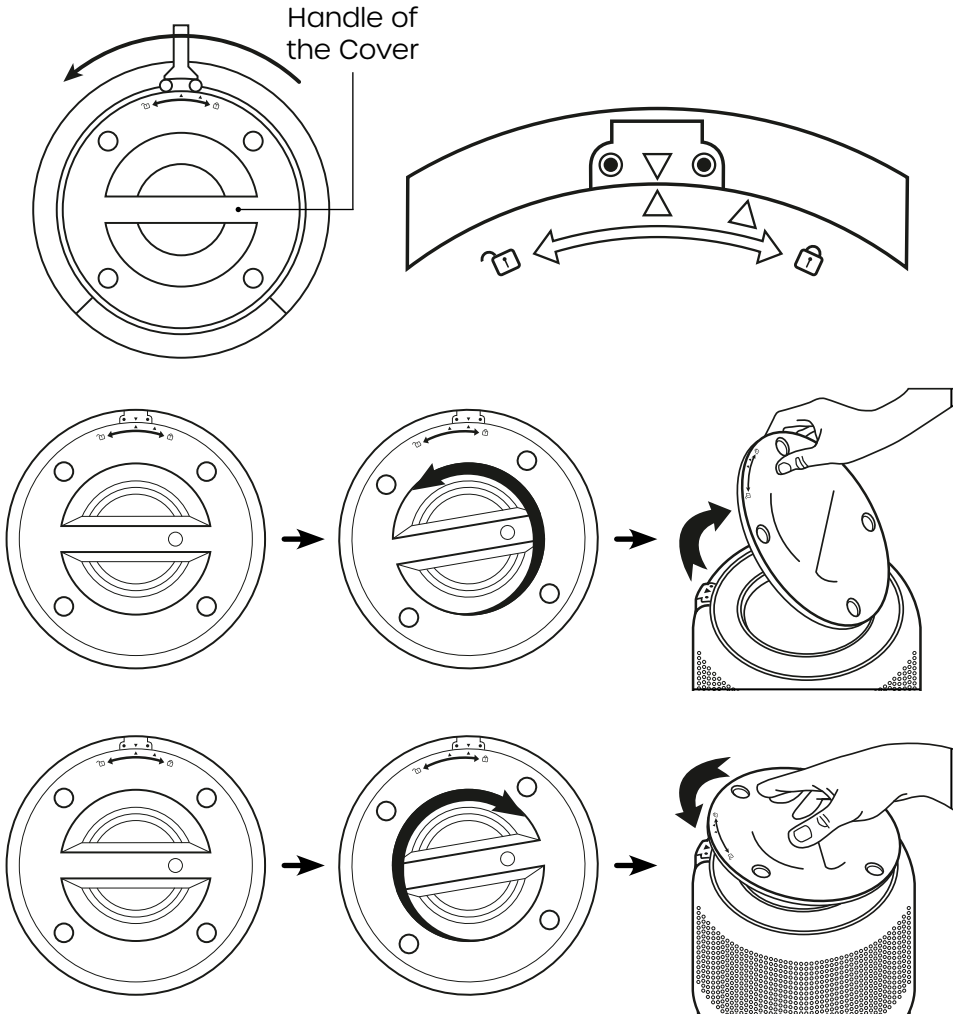



## 2. Filter installation

Then take out the filter, remove the plastic bag, and put the filter back into the compartment. Then close with the cover and turn the handle in the direction of the 'locked' lock  to the right.

Turn the appliance back to the upright position.

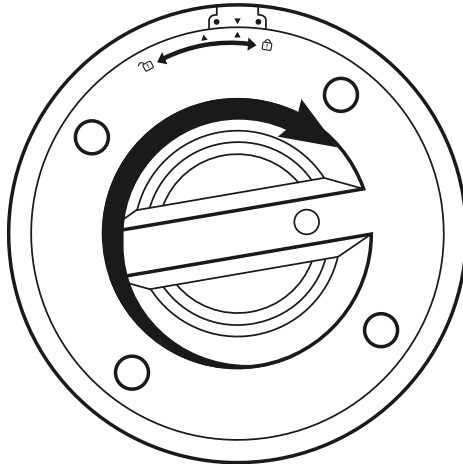
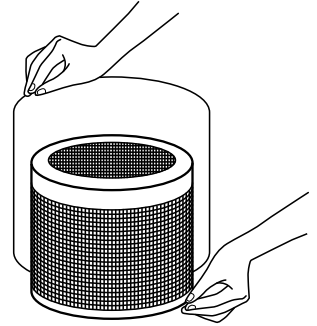
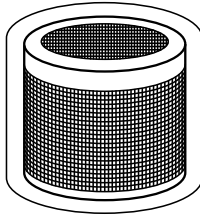
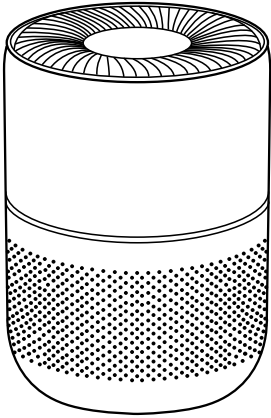





### 3. Essential oil sponges

Two sponge diffusers are inside the product at the back of the cover. Applying a few drops of essential oils on the sponges allows the diffusion of a perfume.

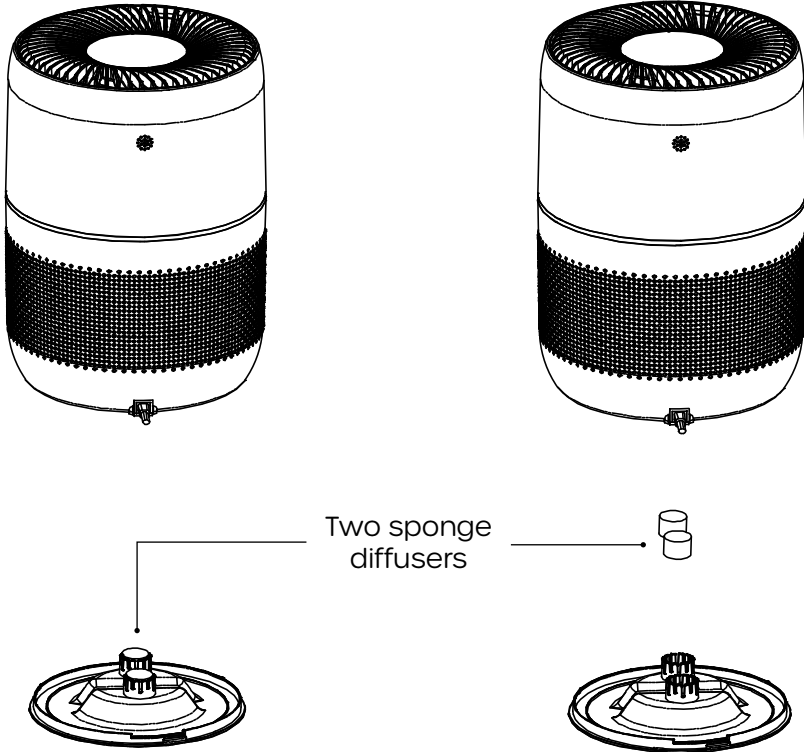



## 4. Operation

Plug-in the unit, a slight beep sounds.



Press the On/Off button to switch on.

By default, the fan speed is medium. 



### **Sleep/speed button**

Allows to select the silent speed suitable for sleep (reduced brightness of the control panel) and the 3 other speeds:

Low  Medium  High 



### **Child lock button**

Press the button for five seconds to activate/deactivate the child safety function.

The indicator will flash indicating that the childproof lock function is activated.

Press and hold for five seconds, the indicator will stop flashing, meaning that the child lock function is deactivated.



### **Filter button**

When the air purifier is switched on, a counter records the number of hours of use.

When the 2000 hours of use are reached, the filter replacement indicator will be in red colour and a sound will be heard. After replacing the filter, press the button for 3 seconds to reset the filter counter. The indicator will light up back to white, and the sound will stop.



### **Timer button**

Press repeatedly to set the timer to automatically turn off the unit between 1h and 8h. Press again to cancel the timer. The selected time is indicated by the corresponding indicator(s).



## CLEANING AND MAINTENANCE

1. Before cleaning the appliance, switch it off and unplug it from the mains.
2. Do not use chemicals or detergents for cleaning that could easily damage or deform your appliance.  
Use a vacuum cleaner to remove dust from air inlet holes.  
Take the filter out of the compartment and remove the dust around the pre-filter.  
Clean the unit with a slightly damp cloth and allow it to dry.  
**Never use the unit without the filter.**



## TECHNICAL SPECIFICATIONS

Description: Air Purifier ECO 15

Model: SAC64010N

Input Voltage: 220-240V

Frequency: 50-60Hz

Power: 30W

Class: II





<b>Problems</b>	<b>Possible reasons</b>	<b>Solutions</b>
Ventilation does not work.	The inlet or outlet of the unit has been blocked. The plastic packaging is not removed.	Remove obstructions around the appliance. Remove the plastic wrapping from the filter.
The performance is poor or the purification capacity is not the best.	The space around the unit is not suitable. The filters are not replaced.	Remove other objects or replace with a new filter.
The machine emits a sound.	Filter is not replaced, filter indicator flashes.	Replace with a new filter, press for 3 seconds to reset the counter.



## DISPOSAL OF UNIT



Appliances bearing the symbol shown here may not be disposed of in domestic rubbish. You are required to dispose of old electrical and electronic appliances like this separately.

Please visit [www.recycle-more.co.uk](http://www.recycle-more.co.uk) or [www.recyclenow.co.uk](http://www.recyclenow.co.uk) for access to information about the recycling of electrical items. Please visit [www.weeeireland.ie](http://www.weeeireland.ie) for access to information about the recycling of electrical items purchased in Ireland. The WEEE directive, introduced in August 2006, states that all electrical items must be recycled, rather than taken to landfill. Please arrange to take this appliance to your local Civic Amenity site for recycling, once it has reached the end of its life.



## WARRANTY

This product is guaranteed for one year from the date of original purchase. If any defect arises due to faulty materials or workmanship the faulty product will be repaired, refunded or replaced at our discretion.

The following conditions apply:

The product must have been purchased from new. Proof of purchase will be required. The product must be installed and used in accordance with the instructions contained in this instruction guide. It must be used only for household and similar purposes such as:

- Staff kitchen areas in shops, offices and other working environments;
- Farm houses and by clients in hotels, motels and other residential type environments;
- Bed and breakfast type environments;
- Catering and similar non-retail applications.

The appliance has not been altered, serviced, dismantled or otherwise interfered with by any person not authorised by Swan.

Any repair work must be undertaken by us or our appointed agent.

Any parts removed during repair work or any appliance that is replaced becomes our property. It does not cover wear and tear, damage, misuse or consumable parts. Swan Products Ltd has no liability for incidental or consequential loss or damage.

This guarantee is valid in the UK and Eire Only.

Helpline: 0333 220 6050

Find advice online: [www.swan-brand.co.uk/support](http://www.swan-brand.co.uk/support)



## BS PLUG

The wires in the mains lead are coloured in accordance with the following code:

BLUE - NEUTRAL

BROWN - LIVE

As the colours of the wire in the mains lead of this appliance may not correspond with the colour markings identifying the terminals on your plug, proceed as follows:

The wire which is coloured BLUE must be connected to the terminal which is marked with the letter N or coloured black. The wire which is coloured BROWN must be connected to the terminal which is marked with the letter L or coloured red.

**WARNING: THIS APPLIANCE IS DOUBLE INSULATED. DO NOT CONNECT ANY WIRE TO THE EARTH PIN.**



## SWAN BRAND HERITAGE



Camden St, Birmingham

## Did you know...

Components for the Swan Teasmade were still being made at the original Bullpitt & Sons factory on Camden St, Birmingham as recently as 2006.



[www.swan-brand.co.uk](http://www.swan-brand.co.uk)

Follow us online



We love  
what we do



Scan this QR code  
to hear about  
our story



we're proud  
of our quality

Copyright © 2022

Swan Products Ltd. PO Box 3117, Stoke-on-Trent ST4 9GD