

**Challenger MDC-2-Pedestal Model &
Challenger MDC-2-Counter Model
Owner's Manual**



Table of Contents

Introduction.....	3
Safety Precautions.....	4
Installation Instructions.....	5
Electrical Connections.....	7
Operating Instructions.....	8
Parts lists	9
Ordering Replacement Parts..	11



Introduction

Miracle Paint Rejuvenator's Challenger MDC-2 mixers are heavy duty quality built machines that offer dependable operation throughout their lifetime.

To take full advantage of your mixer's capabilities, you should understand its features and proper operation. Before operating mixer read this manual completely and save for future reference.

Machine Models

This manual includes instructions and replacement parts information for the MDC-2 Pedestal Base and Counter Base models.

- 110V 60 Hz mixers.
- Mounting bases: Counter-base, Pedestal base.
- 30 minute dial timer.

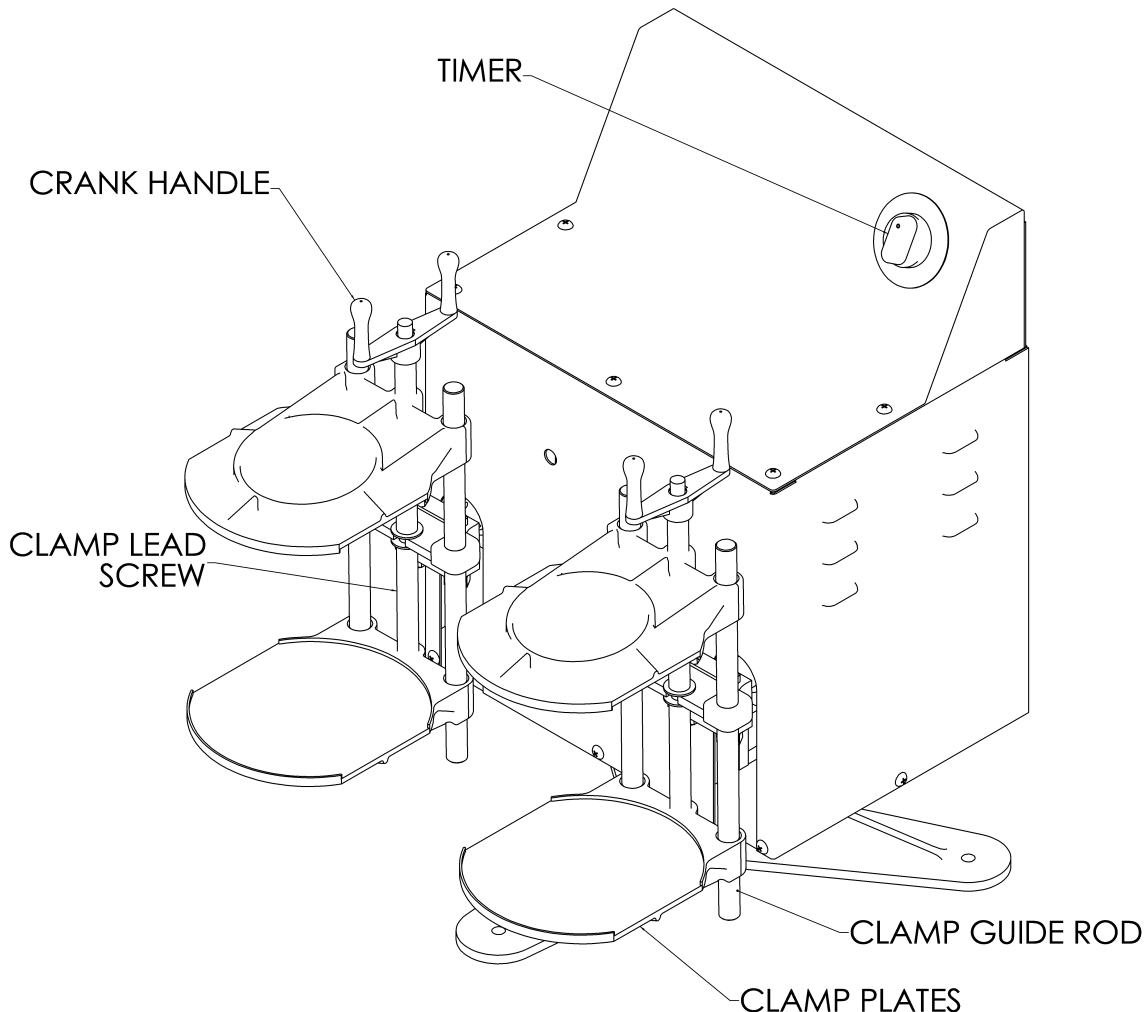



Safety Precautions

Follow these safety precautions when operating the Miracle Paint Rejuvenators MDC-2 Dual Arm Mixer.

Installation

1. Before operating the machine, read this Owner's manual carefully.
2. Ground the machine properly. Be sure to follow proper grounding and electrical procedures.
3. Avoid dangerous environments. Do not use the machine in a damp or wet environment.
4. Use the proper power source. Plug mixer into 110V grounded outlet.
5. Avoid extension cords. To minimize the risk of circuit overload, or improper electrical grounding do not use extension cords.

Operation

6. Ensure the can being mixed is securely clamped.
7. Keep customers away from mixing area. Only trained personnel should operate the mixer.

Maintenance

8. Do not get the timer, control panel or wiring wet. Failure to do so could result in electric shock.
9. Clean all surfaces of the machine with soap and water. Do not use any solvent-based cleaners or thinners.
10. Disconnect machine from power source before cleaning or servicing mixer.
11. Be sure to maintain the mixer on a regular basis. Follow the maintenance procedures on page 8.

SAFETY INSTRUCTIONS

- Review Owner's Manual before operating.
- Ensure container is securely clamped.
- Use of clamp safety covers are recommended.
- Disconnect power source before servicing machine.

! WARNING

EXPLOSION HAZARD



- Consult the Owners Manual before installing or operating.
- Do Not use in hazardous environment where dust or flammable vapors are present.
- Do Not mix flammable materials or materials with a low flashpoint per the material safety data sheet.



Installation Instructions

Installing counter stand model mixer:

1. The counter stand model mixer is shipped fully assembled.
2. Place mixer on counter or table top.
3. Make sure the (4) 3/8-16 hex head screws and (4) jam nuts are full tightened before operation.
4. Plug the power cord into a grounded receptacle (see page 7).
5. Anchor Mixer to table top with appropriate hardware (not included).
6. Use of isolator cup feet is optional (sold separately).

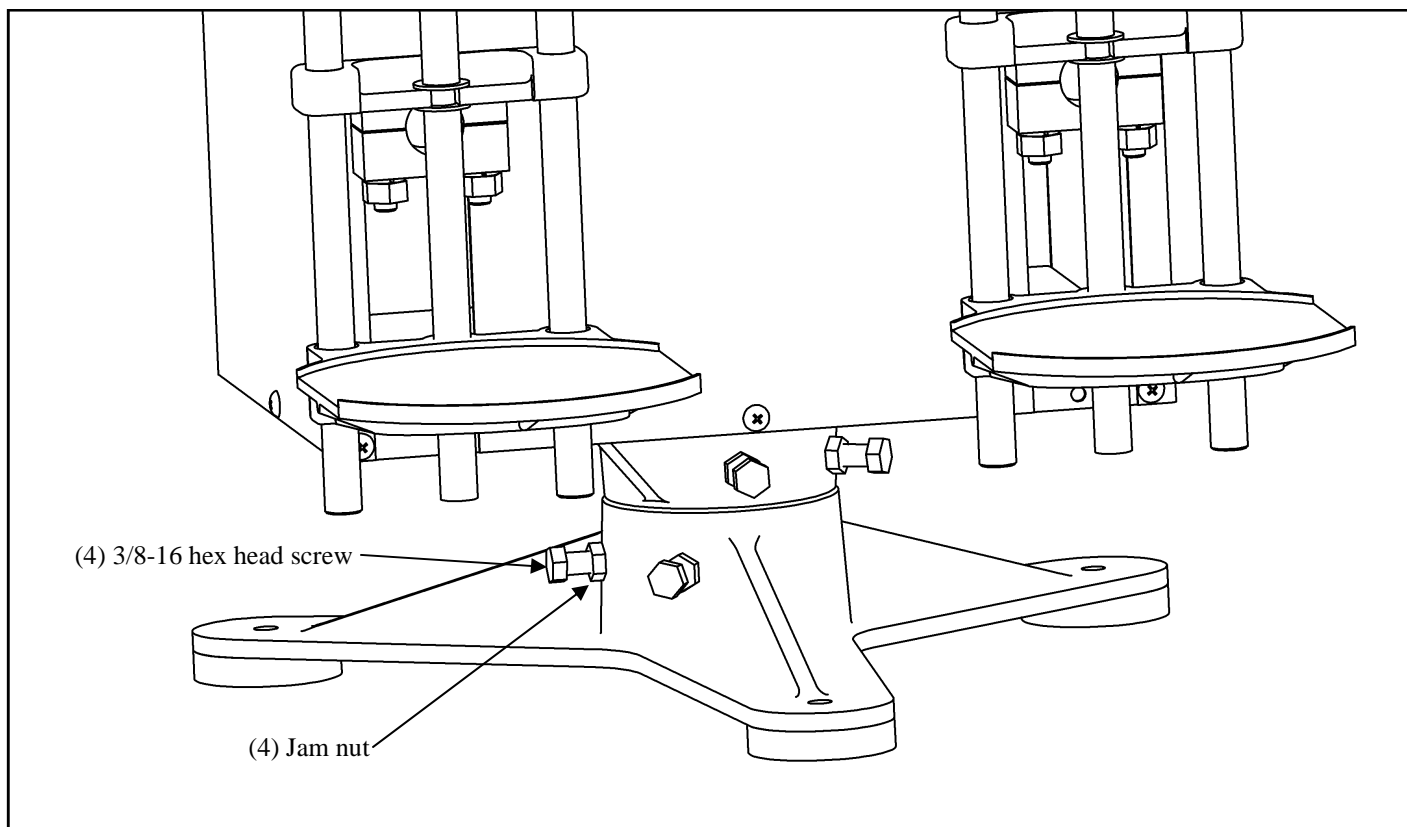

Installing pedestal stand model mixer:

1. Loosen the (2) 3/8-16 hex head screws and (2) jam nuts on the bottom base.
2. Loosen the (2) 3/8-16 hex head screws and (2) jam nuts on the top base.
3. Insert the pedestal tube into the bottom base. Fully tighten (2) 3/8-16 hex head screws against the pedestal tube. Tighten the (2) jam nuts against bottom base.
4. Repeat step 3 for top base.
5. Set mixer in place on floor.
6. Make sure the (4) 3/8-16 hex head screws and (4) jam nuts are full tightened before operation.
7. Plug the power cord into a grounded receptacle (see page 7).
8. Anchor Mixer to floor with appropriate hardware (not included)
9. Use of isolator cup feet is optional (sold separately).

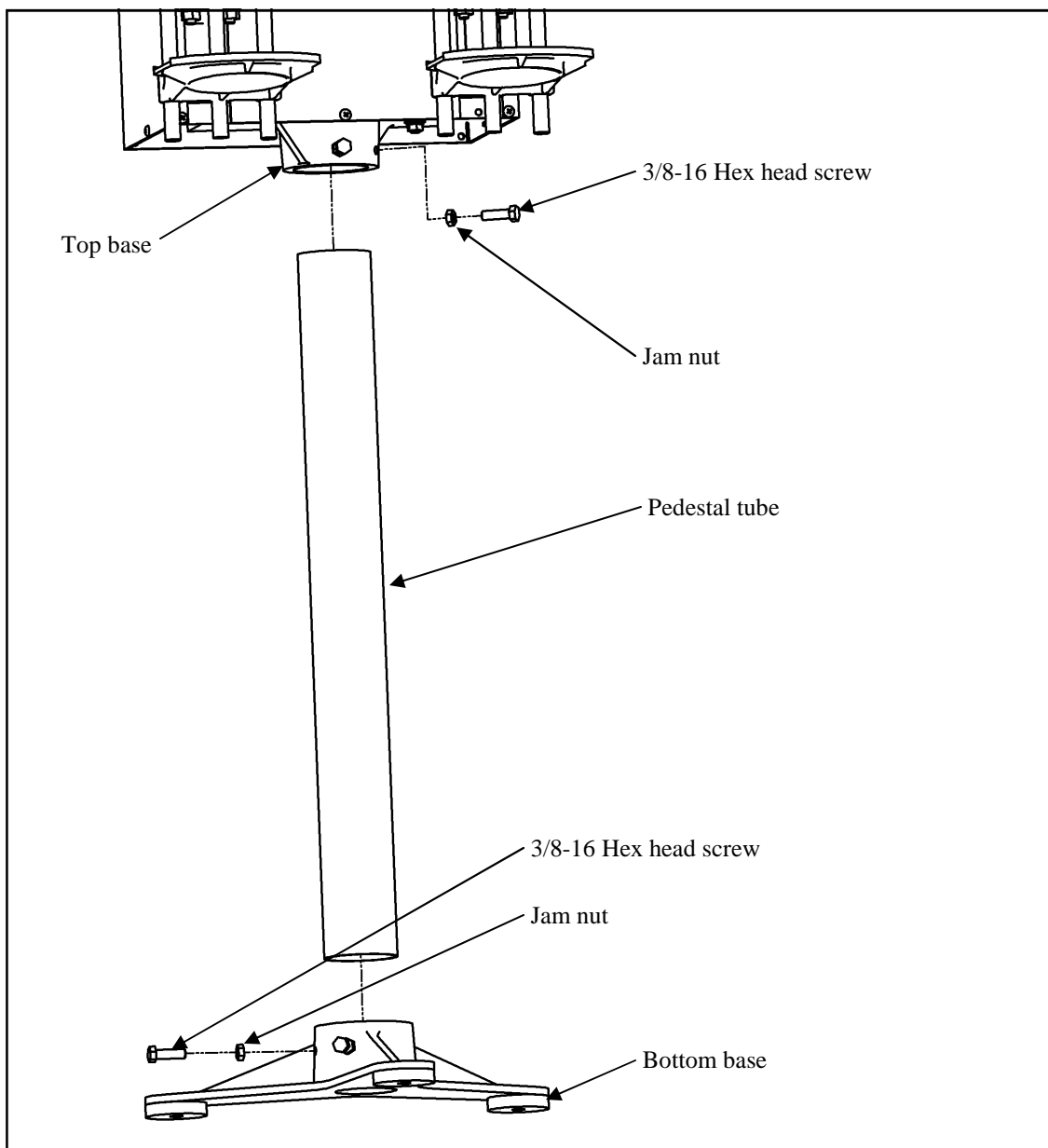



Electrical Connection and Grounding Requirements

⚠ WARNING
RISK OF ELECTRIC SHOCK.
ALWAYS HAVE MACHINE PROPERLY GROUNDED.

Your mixer **MUST BE PROPERLY GROUNDED**. If there is an electrical short circuit, grounding reduces the risk of electric shock.

The machine's power cord has a grounded plug. This plug must be inserted into an electrical outlet that is properly installed and grounded according to all local codes and ordinances.

If you must repair or replace the power cord or plug, do not connect the grounding wire to either flat-blade terminal. The wire with insulation having an outer surface that is green (with or without yellow stripes) is the grounding wire. Check with a qualified electrician if you don't completely understand these grounding instructions, or if you are not sure whether the machine is properly grounded. **DO NOT MODIFY** the plug provided: if it won't fit the outlet, have a proper outlet installed by a qualified electrician.

Extension Cords

Avoid using extension cords. If an extension cord is unavoidable, consult a qualified electrician to determine what type of extension cord will satisfy the grounding, current capacity, and other requirements of the particular situation.



Operation

Safety Precautions

1. Before operating the machine, read this Owner's manual carefully.
2. Ground the machine properly. Be sure to follow proper electrical connection and grounding requirement procedures.
3. **Do not use in hazardous environment where dust or flammable vapors are present. Do not mix flammable materials or materials with a low flashpoint per the material safety data sheet.**
4. Make sure can lids are tightly closed.
5. Do not mix breakable containers such as glass, porcelain, etc.
6. Ensure container is securely clamped.
7. All customers should be kept away from the work area.
8. The mixer should be operated by trained personnel only.

NOTE: The motor is protected by a thermal overload cutoff switch. If the temperature of the motor gets too hot it will automatically shut off. The motor will not start again until it has cooled down.

Mixing Procedure

1. Turn the clamp handle counter-clockwise to open the clamp.
2. Place the container to be mixed in the clamp and turn the clamp handle clockwise until the container is secured.
3. If mixing only one container, clamp an empty can (or a piece of 2" x 4" board) in the other clamp.
4. After the containers are secured, set the timer for desired mix time.
5. The mixer will turn off after the mix time has elapsed.

Maintenance Procedures

Always disconnect machine from power source before maintaining or servicing.

Cleaning:

Keep the machine clean. Colorant or paint spilled on the machine can be cleaned with warm soapy water and/or mineral spirits. After washing, oil the clamp plate guides and clamp lead screw with 3in1 oil. Be careful not to get the timer wet.

Lubrication:

Keep the clamp guide rods and clamp lead screws free of dirt, dried paint, and other materials. Remove any small nicks with a fine file. **Once a week apply a thin film of 3in1 oil to the clamp guide rods and clamp lead screws.**

Frame & Drive Assembly

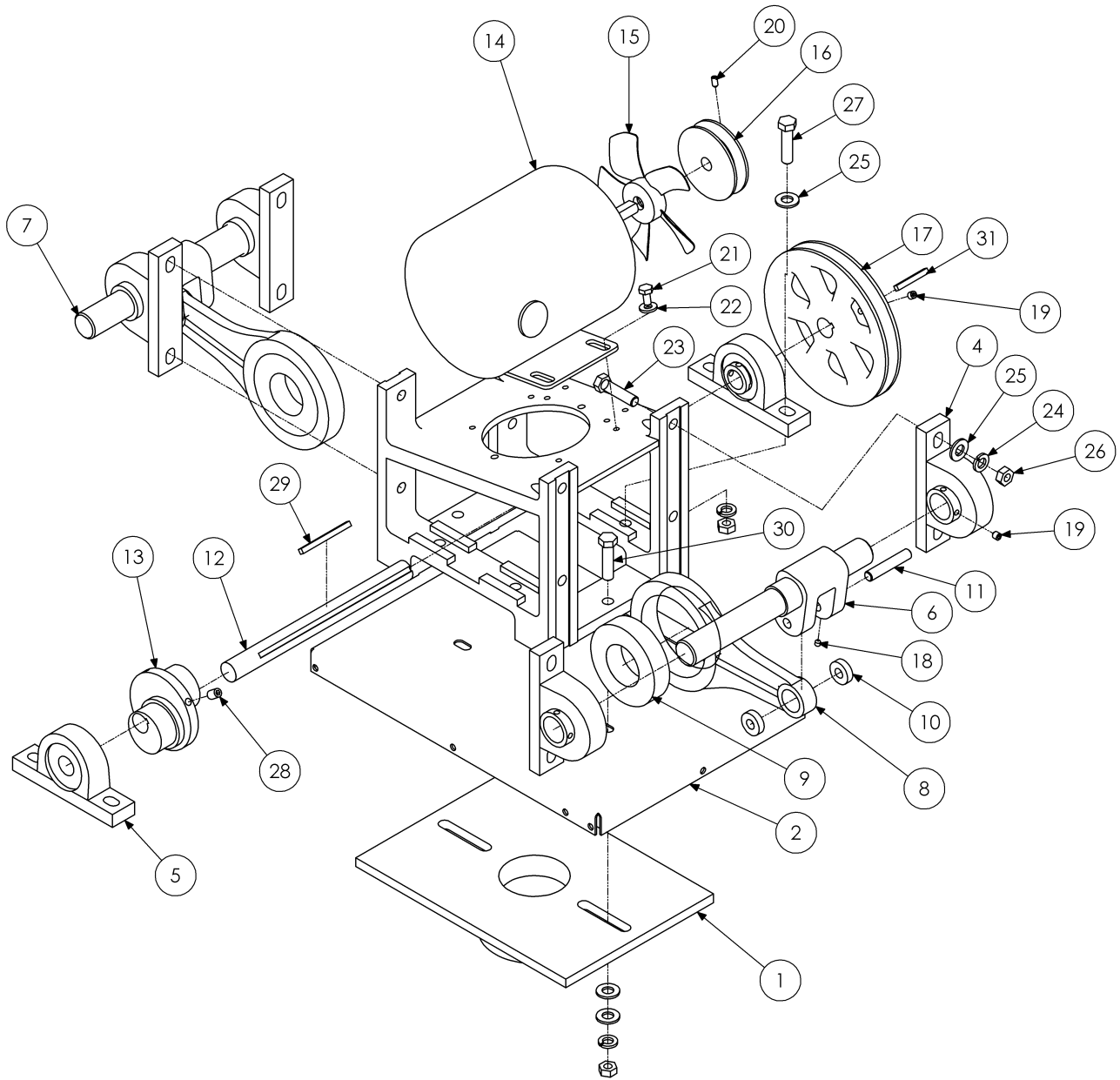

Item	Qty.	Part Number / Description
1	1	Base casting
2	1	Sheet metal base
3	1	C3 Frame
4	4	DC-4 1" Pillow block bearing
5	2	DC-2 3/4" Pillow block bearing
6	1	DC-10 1" Steel shaft (L5)
7	1	DC-9 1" Steel shaft (R6)
8	2	DC-6 Pitman
9	2	DC-5 Pitman main bearing
10	4	DC-8 Pitman bearing
11	2	DC-7 3/8" Dowel pin
12	1	DC-1 3/4" Steel shaft
13	1	DC-3 Two-way eccentric
14	1	110V/60Hz Motor
15	1	Motor fan
17	1	DC-13 Drive pulley
18	4	Set screw, 10-32 x .187
19	9	Set screw, 1/4-20 x .25
20	1	Set screw, 10-32 x .375
21	4	Hex head screw 1/4-20 x .50
22	4	1/4" Flat washer
23	8	Hex head screw 3/8-16 x 1.50
24	14	3/8" Lock washer
25	16	3/8" Flat washer
26	14	3/8-16 Hex nut
27	4	Hex head screw 3/8-16 x 2.00
28	2	Set screw 5/16-18 x .50
29	1	Square key 3/16" x 2.50
30	2	Hex head screw 3/8-16 x 1.75
31	1	Square key 3/16" x 1.50

Enclosure Assembly

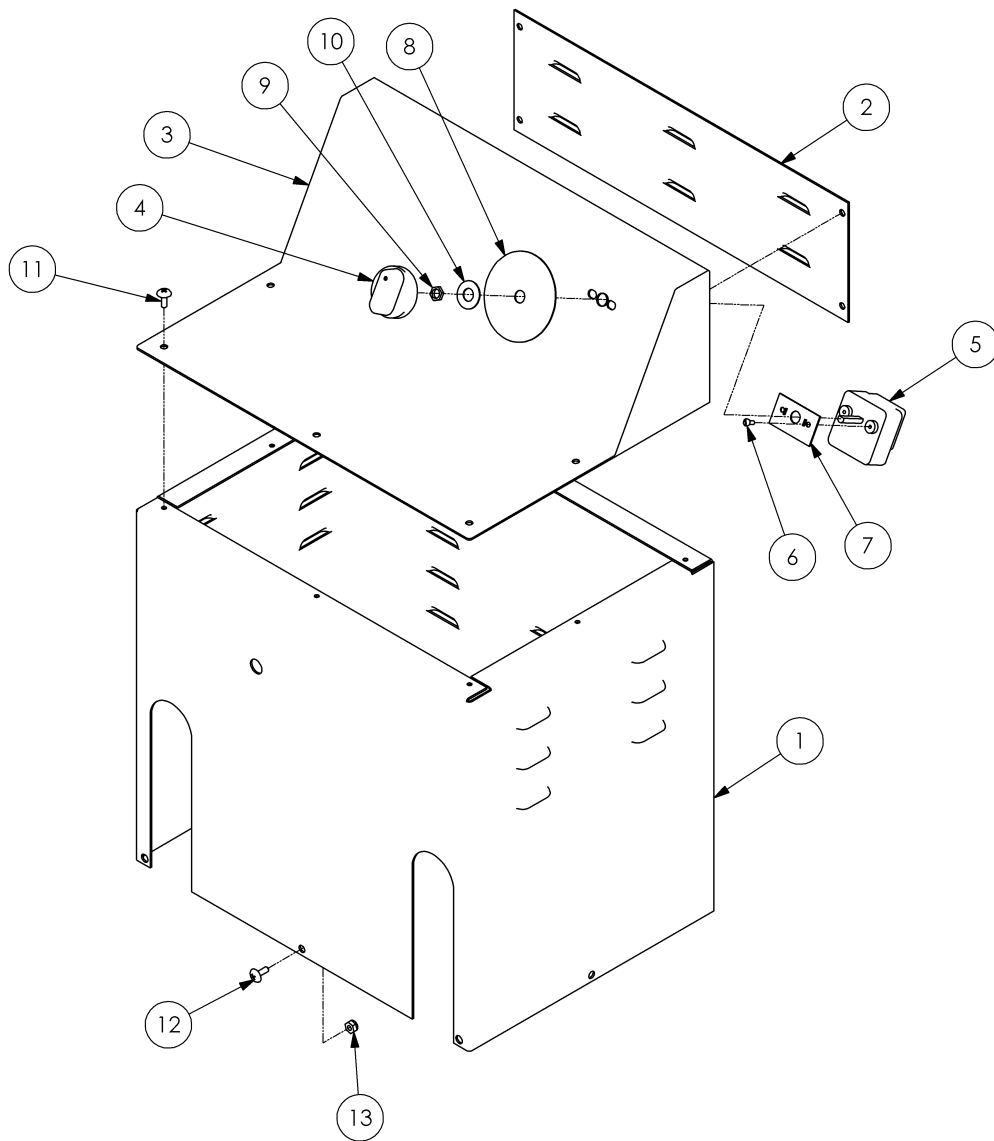

Item	Qty.	Part Number / Description
1	1	Main enclosure
2	1	Rear panel
3	1	Top panel
4	1	Timer knob
5	1	Timer
6	2	Self tapping screw #4 x 5/16"
7	1	Timer backing plate
8	1	Timer faceplate
9	1	Timer nut
10	1	Flat washer
11	9	Truss head sheetmetal screw #10 x .50
12	8	Truss head screw 10-32 x .50
13	8	Keps nut 8-32

DC-50 Clamp Assembly

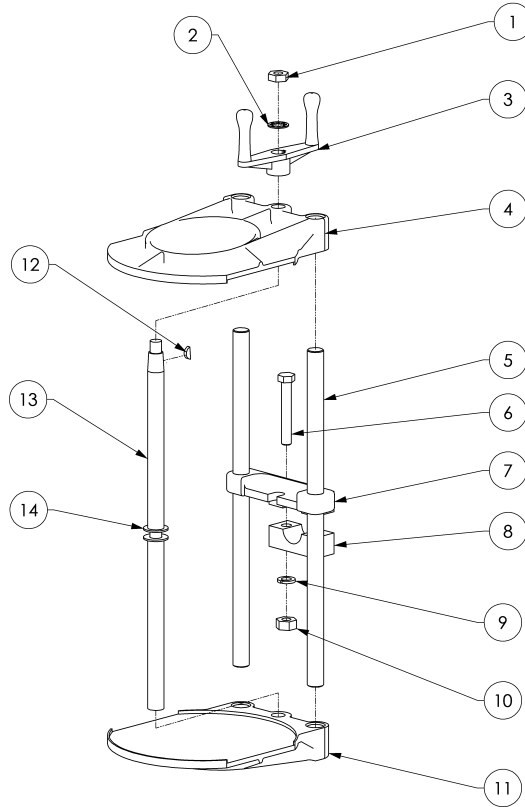

Item	Qty.	Part Number / Description	Item	Qty.	Part Number / Description
1	1	7/16-20 Jam hex nut	8	1	PIM-10242 Clamping block
2	1	7/16" Lock washer, internal tooth	9	2	3/8" Lock washer
3	1	MDC-104 Clamp handle, MDC	10	2	3/8-24 Hex nut
4	1	MDC-101 MDC Clamp plate, top	11	1	MDC-102 MDC clamp plate, bottom
5	2	MDC-103 Guide rod, MDC	12	1	#404 Woodruff key
6	2	Hex head tap bolt 3/8-24 x 2.50	13	1	MDC-106 Clamp lead screw, MDC
7	1	MDC-105 Guide rod holder, MDC	14	2	Thrust bearing, MDC clamp



Ordering Replacement Parts

Contact our Customer Service Department at:

Miracle Paint Rejuvenator Company
 6160 Claude Way East
 Inver Grove Heights, Minnesota 55076

Ph: 651-222-1900 or 888-236-1143
 Fax: 651-222-8549