

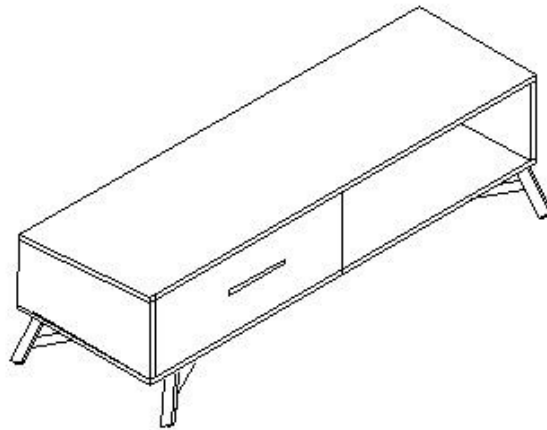

W A Z O
ASSEMBLY INSTRUCTIONS



MAURA

MAURA MANGO 1 DWR COFFEE TABLE
T5903



W A Z O

MAURA MANGO 1 DWR COFFEE TABLE

Page 2 of 4

ASSEMBLY INSTRUCTIONS

Read these instructions carefully and keep for future reference. Ensure that you have all the Pieces before starting assembly by referring to the parts inventory. When starting assembly, Place all pieces on a soft, clean, and flat surface like a carpet to prevent scratches or damage.

If you are having difficulty, our VIP Team is always here for you. Call us at **1-800-684-6014** During business hours or email us at service@wazofurniture.com.

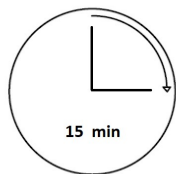

TIME

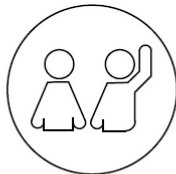

OF PEOPLE

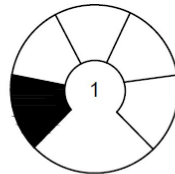

DIFFICULTY



REQUIRED TOOL
ALLEN KEY



ANTI-TIP
Installation Required

PARTS INVENTORY		
ID	DESCRIPTION	QTY
A	1 DWR COFFEE TABLE	1
B	IRON LEG SET OF 2	1



W A Z O

MAURA MANGO 1 DWR COFFEE TABLE

Page 3 of 4



IMPORTANT NOTES

1. Please check that all parts are present before starting assembly.
2. For the protection of your furniture and to ensure it is not damaged in the assembly process, place all parts on a clean, smooth surface.
3. In order to align all screws properly, tighten all screws halfway first until product frame is assembled and then tighten fully when all screws are aligned.
4. Do not use power tools for assembly.
5. Please periodically check all fittings and re-tighten as necessary.
6. Do not use furniture unless all bolts and screws are firmly secured.



Structural integrity is warranted only if all fasteners are properly installed & tightened, and the product is moved only per instructions.



HARDWARE / TOOLS INVENTORY		
ID	DESCRIPTION	QTY
A	ALLEN KEY BOLT 8X12 	8
B	ALLEN KEY 5MM 	1



W A Z O

1

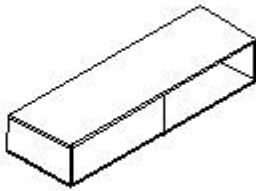

2

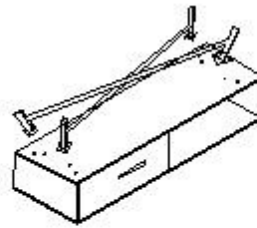

3

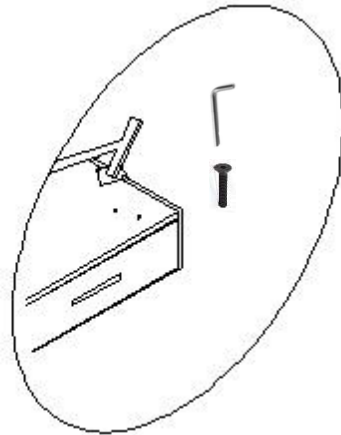

4

