

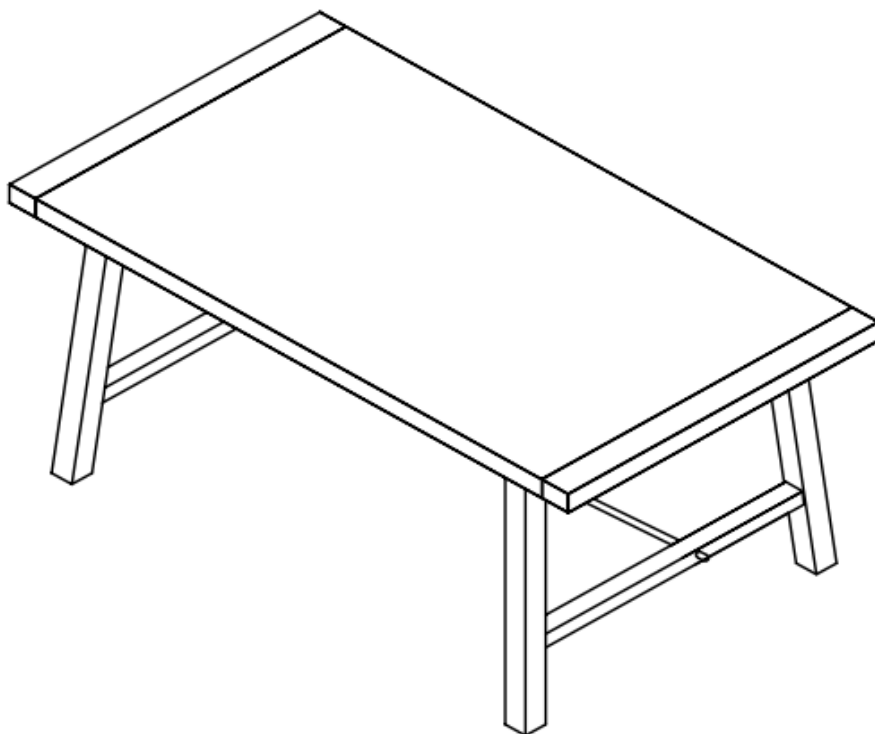

**W A Z O**

ASSEMBLY INSTRUCTIONS



**COUNTRYSIDE**

Dining Table

### ASSEMBLY INSTRUCTIONS

Read these instructions carefully and keep for future reference. Ensure that you have all the pieces before starting assembly by referring to the parts inventory. When starting assembly, place all pieces on a soft, clean, and flat surface like a carpet to prevent scratches or damage.

If you are having difficulty, our VIP Team is always here for you. Call us at **1-800-684-6014** during business hours or email us at **service@wazofurniture.com**.



15 min



TIME







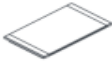

OF PEOPLE



DIFFICULTY

NO.	NAME	QTY	Visual
①	Table Top	1	
②	Table Base	2	
③	Stretchers	1	

NO.	NAME	QTY	Visual
A	Bolt	8	
B	Spring Washer	8	
C	Washer	8	
D	Nut	2	
E	Flat Washer	2	
F	Allen Key	1	



---

### IMPORTANT NOTES

1. Please check that all parts are present before starting assembly.
  2. For the protection of your furniture and to ensure it is not damaged in the assembly process, place all parts on a clean, smooth surface.
  3. In order to align all screws properly, tighten all screws halfway first until product frame is assembled and then tighten fully when all screws are aligned.
  4. Do not use power tools for assembly.
  5. Please periodically check all fittings and re-tighten as necessary.
  6. Do not use furniture unless all bolts and screws are firmly secured.
- 

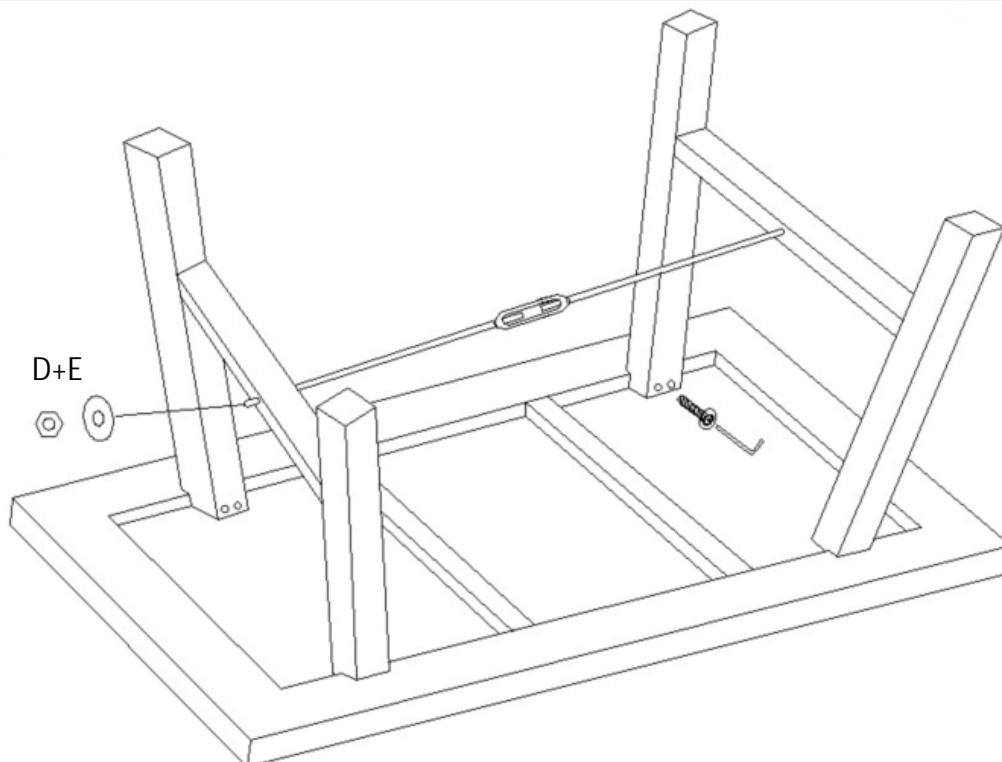

1. Assemble Stretcher(3) to Leg (2) by inserting the dowel at two ends of the stretcher(3) into pre-drilled holes at center of the leg. lock it by nut(D) and Flat washer(E).
2. Secure by washer(C), spring washer(B) and the Bolt(A) as diagram, using Allen Key(F).