

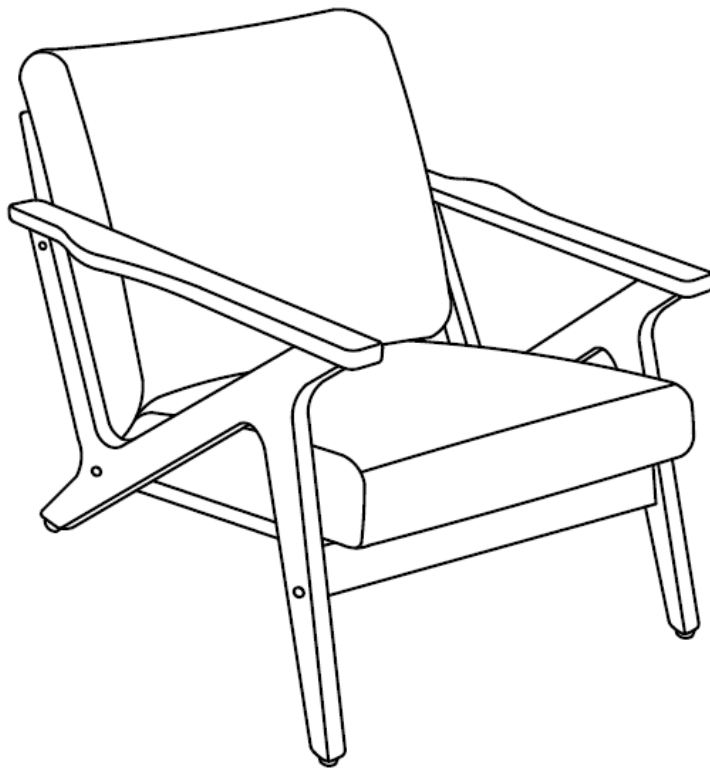

W A Z O

ASSEMBLY INSTRUCTIONS

VERSION1.0



T6362-1/2 BIANCA

1 SEATER SOFA



ASSEMBLY INSTRUCTIONS

Read these instructions carefully and keep for future reference. Ensure that you have all the pieces before starting assembly by referring to the parts inventory. When starting assembly, ace all pieces on a soft, clean, and flat surface like a carpet to prevent scratches or damage.

If you are having difficulty, our VIP Team is always here for you. Call us at **1-800-684-6014** during business hours or email us at **service@wazofurniture.com**.



TIME



2 OF PEOPLE







DIFFICULTY

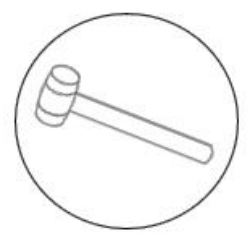

REQUIRED TOOL



| PARTS INVENTORY | | |
|-----------------|---|-----|
| ID | DESCRIPTION | QTY |
| A | SOFA LEG (L/R)  | 2 |
| B | FRONT RAIL  | 1 |
| C | BACK FRAME  | 1 |
| D | SEAT FRAME  | 1 |

**IMPORTANT NOTES**







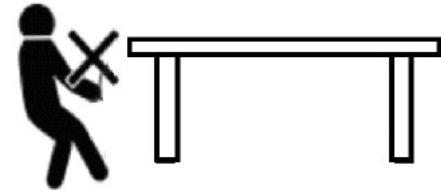

1. Please check that all parts are present before starting assembly.
2. For the protection of your furniture and to ensure it is not damaged in the assembly process, place all parts on a clean, smooth surface.
3. In order to align all screws properly, tighten all screws halfway first until product frame is assembled and then tighten fully when all screws are aligned.
4. Do not use power tools for assembly.
5. Please periodically check all fittings and re-tighten as necessary.
6. Do not use furniture unless all bolts and screws are firmly secured.



Structural Integrity is warranted only if all fasteners are properly installed & tightened, and the sideboard is moved only per instruction.



DO NOT DRAG TABLE, ALWAYS LIFT WITH AT LEAST TWO PEOPLE BEFORE MOVING

| HARDWARE / TOOLS INVENTORY | | |
|----------------------------|--|------|
| ID | DESCRIPTION | QTY |
| 1 | JCBC M6 x 50mm + S/W M6 + F/W M6 x 13mm  | 6PCS |
| 2 | ALLEN KEY M4 (BALL SHAPE)  | 1PC |
| 3 | BARREL NUT M6 x 13mm  | 4PCS |
| 4 | WOOD BUTTON Ø14.5  | 6PCS |
| 5 | FH SCREW #8 x 32mm  | 2PCS |
| 6 | WOOD DOWEL M10 x 40mm  | 4PCS |
| 7 | L BRACKET  | 2PCS |
| 8 | CSK SCREW M3.5 x 16mm  | 4PCS |
| 9 | PVC NAIL 5/8" (WITH PIN)  | 4PCS |



1

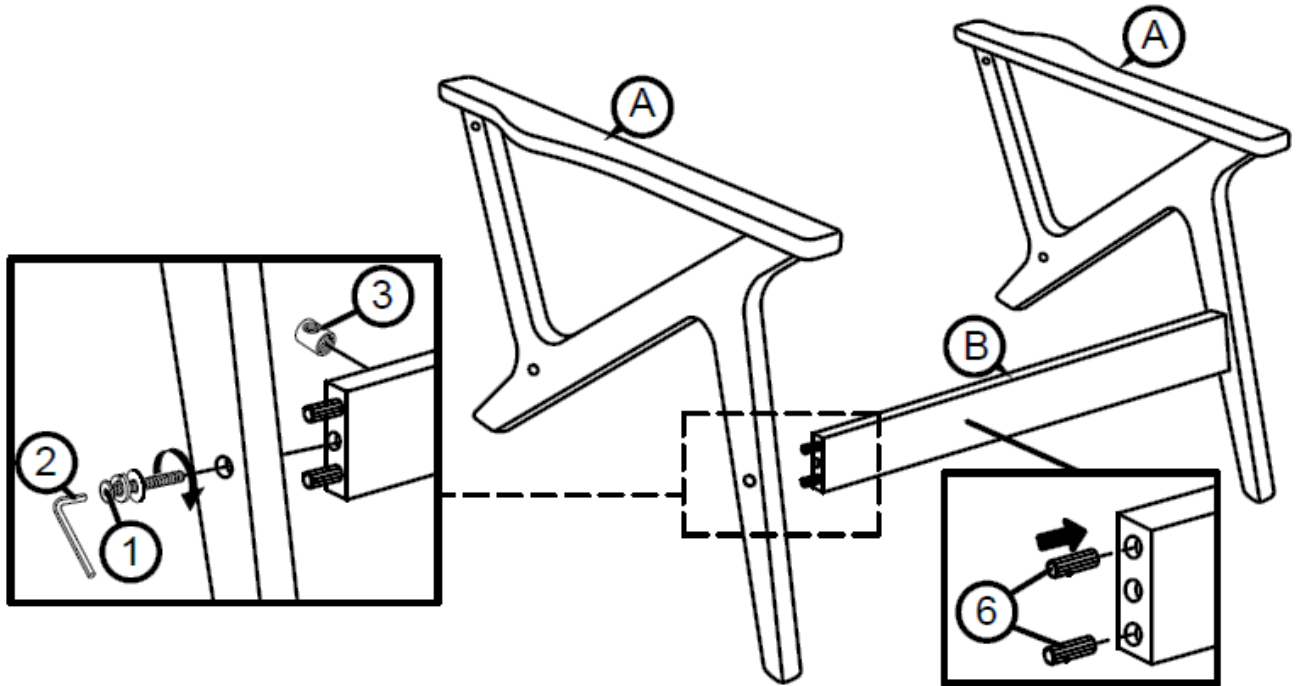

DO NOT FULLY TIGHTEN THE BOLT

2

(NEED 2 PERSONS)

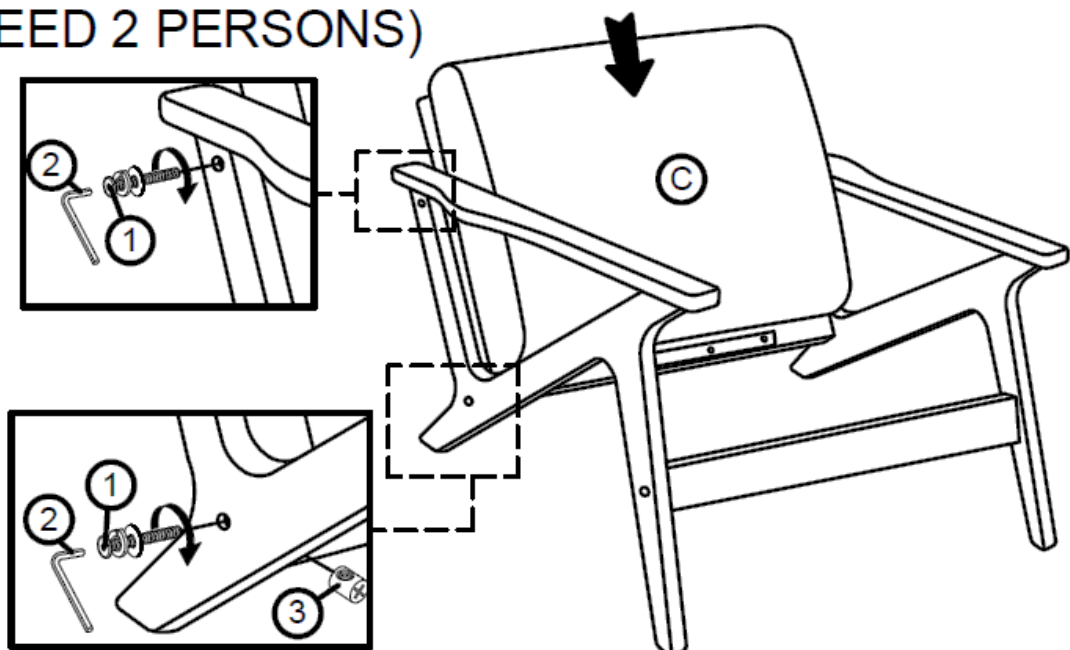



3

(NEED 2 PERSONS)

Note:
Push the cushion seat
harder before fixing the
screws (step 3.a).

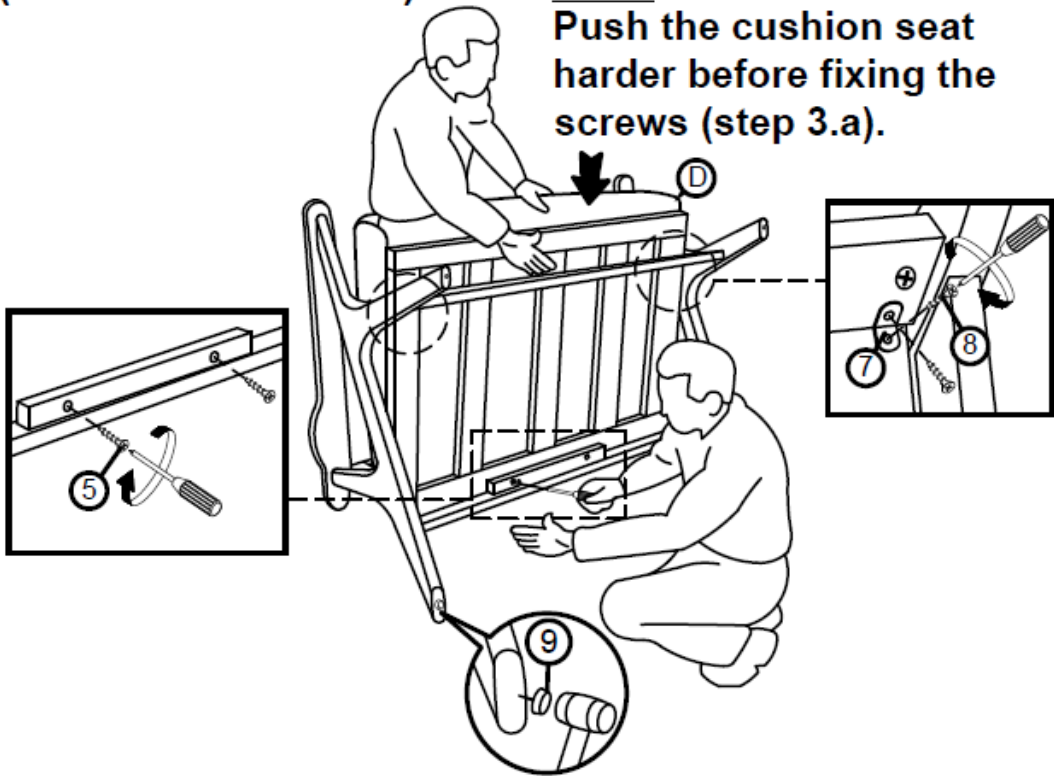

4

