

## Installation

# Replacement PSU PCB & Cover (VCS-PSU-N)

**Honeywell**  
GENT

These instructions show how to install the replacement PSU PCB assembly and cover (VCS-PSU-N) in to a Vigilon Compact panel, either COMPACT-24 (non networkable) or COMPACT-24-N (networkable) panel or Nano panel (NANO-24). The package contains:



1 - Replacement PSU PCB assembly



1 - Replacement Cover  
Not used on Nano panel

### To replace the PSU in a Vigilon Compact panel



Isolate the mains power supply to the Vigilon Compact panel.

#### Removal

- Open the outer and inner doors of the panel.
- Disconnect the mains cable from the mains terminals ① at PSU PCB assembly and unplug the battery circuit cable from connector ②.
- Remove the two nuts and washers from the panel ③ (**keep for later use**) and lift out the cover ④ or ⑤.
- Disconnect the ribbon cable ⑥.
- Remove the two screws and washers that secure the PSU assembly ⑦ (**keep for later use**) and lift out the PSU PCB assembly ⑧ or ⑨ from the clinching standoffs.

#### Replacement

- Fit the **Replacement PSU PCB assembly ⑧** on to the two self clinching standoffs.



Ensure that the Replacement PSU PCB assembly is secured using screws and washers at the two fixing points ⑥.

- Reconnect the ribbon cable ⑥ between Replacement PSU PCB assembly and MCB assembly.
- Align the **Replacement cover ④** with the two fixings on the panel side. Slide the cover down and secure it using the nuts and washers ③.
- Reconnect the mains cable to mains terminals ① on the Replacement PSU PCB assembly.
- Reconnect the battery circuit to connector ② on Replacement PSU PCB assembly.
- Close the inner and outer doors of the panel.

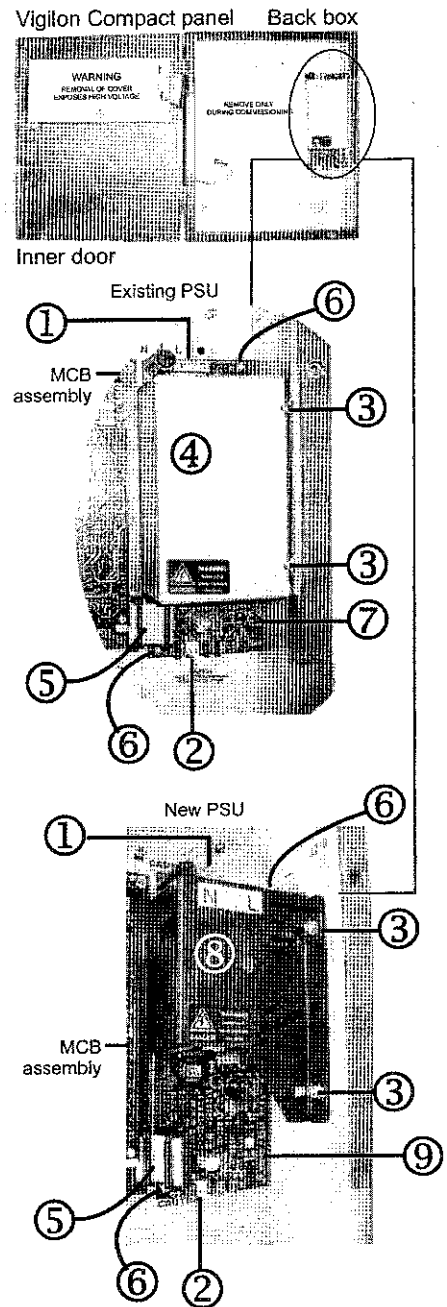

**To replace PSU in a Nano panel**

 First isolate the mains power supply to the Nano panel.

**Removal**

- a. Remove the 'Screw cover' plate, which is held in by magnets. Open the fixing screws ① and then open out the bottom ② of the 'Outer Cover' and lift it up and out ③.
- b. Disconnect the mains cable from the mains terminals ⑩ at PSU PCB assembly and then disconnect the battery supply.
- c. Disconnect the flat flexible cable from the Main Control Board at socket P3 by pulling up the stops ⑥ of the socket and by lifting out the cable ⑦. Remove the ferrite core from the cable.
- d. Remove the 'LCD Assembly' from the electronic module by flexing out the hinge tab ⑧ located on the top-right of the electronic module and carefully remove the 'LCD Assembly' from the electronic module.

- e. Disconnect the ribbon cable ⑬ and battery cable ⑫ from the PSU PCB.
- f. Remove the four screws and washer ⑪ that secure the PSU PCB and lift out the PSU PCB.

**Replacement**

- a. Fit the **Replacement PSU PCB assembly** and secure the board to the electronic module using ⑪ screws and washers.
- b. Reconnect the ribbon cable, battery connector and mains cable.
- e. Reassemble the 'LCD Assembly'.
- f. Fit the ferrite core to flexible cable and reconnect the flexible cable to the MCB.

 Ensure the flexible cable is securely fitted with stops locked-in.

- g. Reconnect the battery supply.
- h. Refit the 'Outer Cover' and secure it to the backbox and then fit the 'Screw Cover' plate.
- i. Power up the panel by switching On the mains supply to the panel.

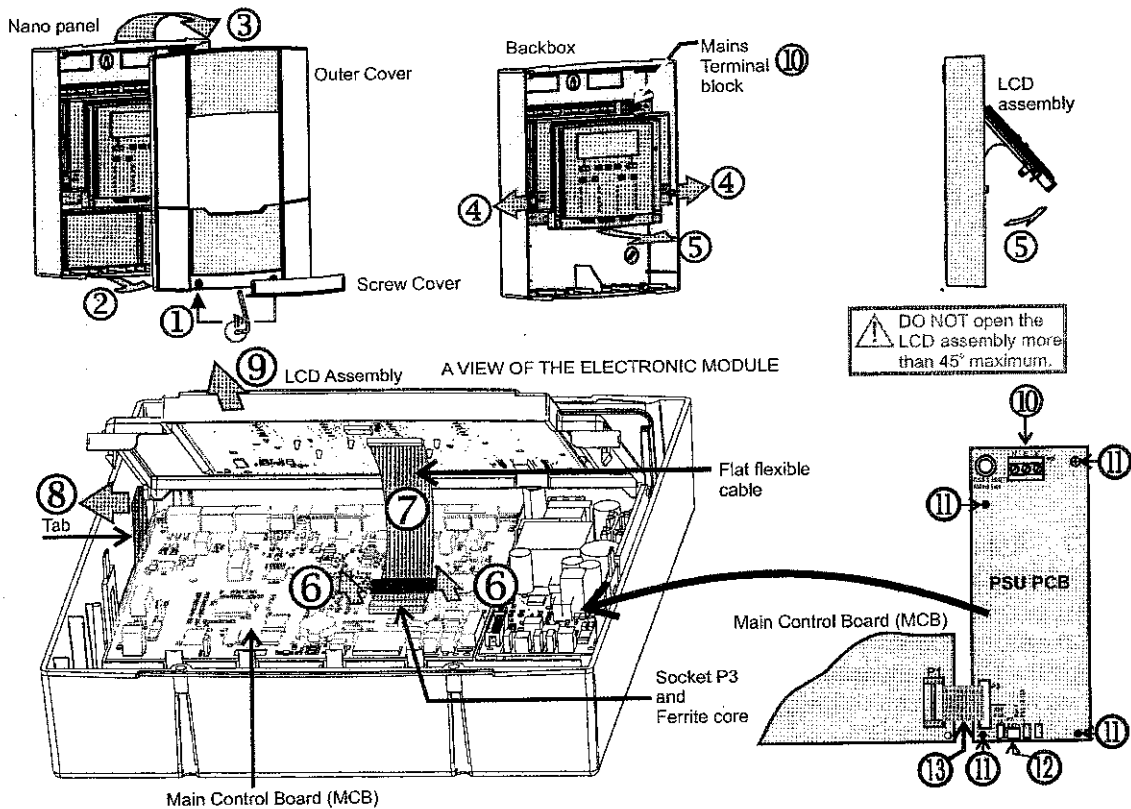

 At the end of their useful life, the packaging, product and batteries should be disposed of via a suitable recycling centre and in accordance with national or local legislation.

 **WEEE Directive:** At the end of their useful life, the packaging, product and batteries should be disposed of via a suitable recycling centre. Do not dispose of with your normal household waste. Do not burn.

Honeywell Gent reserves the right to revise this publication from time to time and make changes to the content hereof without obligation to notify any person of such revisions of changes.

	Hamilton Industrial Park, Waterside Road, Leicester LE5 1TN, UK	Website: <a href="http://www.gent.co.uk">www.gent.co.uk</a>
	Telephone: +44 (0) 116 246 2000	Fax (UK): +44 (0)116 246 2300