

CF3000 range - Intelligent addressable control panel



Eaton's CF3000 is a high specification intelligent addressable control panel which is available in various loop configurations. These panels combine sophisticated functionality with simple operation and an aesthetically pleasing design.

The large capacity, ability to support complex cause and effect programming and wide range of user controllable functions make the system suitable for a diverse range of projects from sheltered housing to large office developments.

The CF3000 uses soft addressing to minimise installation time and remove the potential for error associated with manual addressing. It can operate as a stand alone panel or as part of a networked system. They have powerful programming options that allow configurable control over whether messages from specific panels are transmitted around the network or remain local.

An extensive range of compatible intelligent addressable systems ancillaries are available to work with the CF3000 all of which incorporate an integral short circuit isolator to provide maximum protection against short circuits on the external loop.

Features and benefits

- Available in 1, 2 and 4 loop versions
- Up to 200 addresses per loop
- Full network capability up to 126 panels
- Event History Buffer (9,999 events) with Date/Time stamp
- Soft addressing
- Large versatile touch screen user interface
- Multi-language selection capability
- Integral printer (optional)
- Integral battery and power supply
- Flexible cause and effect programming
- Simple to operate end user touch-screen interface
- Flexible distributed network capability
- Full range of compatible accessories
- Easy to design system cause and effect using site installer software
- Full system integrity with Eaton's managed protocol

Specifier's guide

2.2 Control panels



Technical specification

Code	CF30001G	CF30002G	CF30004G
Description	1 loop control panel	2 loop control panel	4 loop control panel
Standards	EN54 Pt2,1997, A1:2006, EN54 Pt4, 1997, A1:2002, A2:2006 EN54 Pt13: 2005	EN54 Pt2,1997, A1:2006, EN54 Pt4, 1997, A1:2002, A2:2006 EN54 Pt13: 2005	EN54 Pt2,1997, A1:2006, EN54 Pt4, 1997, A1:2002, A2:2006 EN54 Pt13: 2005
Specification			
Number of loops	1	2	4
Addresses per loop	200	200	200
Number of conventional sounder circuits	4 monitored for open and short circuit	4 monitored for open and shortcircuit	4 monitored for open and short circuit
Auxiliary fire routing equipment output (monitored)	24V 30mA (max)	24V 30mA (max)	24V 30mA (max)
Auxiliary fire protection equipment output (monitored)	24V 30mA (max)	24V 30mA (max)	24V 30mA (max)
Auxiliary fault routing equipment output (monitored)	12V 30mA (max)	12V 30mA (max)	12V 30mA (max)
System operating voltage	24V dc (nom)	24V dc (nom)	24V dc (nom)
Mains input supply	230V ac +10% / -15%	230V ac +10% / -15%	230V ac +10% / -15%
Class change facility	Terminals for connection of external contacts, can also be instigated via input interface	Terminals for connection of external contacts, can also be instigated via input interface	Terminals for connection of external contacts, can also be instigated via input interface
Auxiliary relay	1 set of changeover contacts operate in event of fire condition	1 set of changeover contacts operate in event of fire condition	1 set of changeover contacts operate in event of fire condition
Output ports	RS485, RS232 for connection of repeaters etc	RS485, RS232 for connection of repeaters etc	RS485, RS232 for connection of repeaters etc
Standby duration	Dependant on loop loading and battery configuration	Dependant on loop loading and battery configuration	Dependant on loop loading and battery configuration
Battery	2 x 12Ah (standard versions)	2 x 12Ah (standard versions) 4 x 12Ah (EB versions)	2 x 12Ah (standard versions) 4 x 12Ah (EB versions)
Environmental			
Operating temperature	-5°C to +40°C	-5°C to +40°C	-5°C to +40°C
Humidity (non condensing)	0 to 75% RH	0 to 75% RH	0 to 75% RH
Physical			
Construction	Back box - mild steel, front door - PC/ABS	Back box - mild steel, front door - PC/ABS	Back box - mild steel, front door - PC/ABS
Dimensions (H x W x D)	Standard versions: 397mm x 497mm x 180mm	Standard versions: 397mm x 497mm x 180mm EB Versions: 397mm x 497mm x 280mm	Standard versions: 397mm x 497mm x 180mm EB Versions: 397mm x 497mm x 280mm
Weight	18kg	18kg	18kg
Ingress protection	IP30	IP30	IP30
Cable entries	Top: 31 cable knockouts (20mm) Back: 12 cable knockouts (20mm)	Top: 31 cable knockouts (20mm) Back: 12 cable knockouts (20mm)	Top: 31 cable knockouts (20mm) Back: 12 cable knockouts (20mm)
System networking	Fully networkable up to 126 panels (requires additional network card - 1 per panel)	Fully networkable up to 126 panels (requires additional network card - 1 per panel)	Fully networkable up to 126 panels (requires additional network card - 1 per panel)

Dimensions

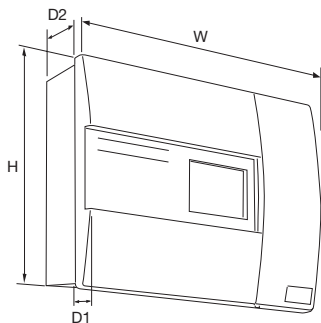

Description	H (mm)	W (mm)	D1 (mm)	D2 (mm)
Standard	397	497	55	125
EB	397	497	55	225

Catalogue numbers

Description	Code
1 Loop control panel	CF30001G
1 Loop control panel, integral printer	CF30001GP
2 Loop control panel	CF30002G
2 Loop control panel, integral printer	CF30002GP
2 Loop control panel, extended battery	CF30002GEB
2 Loop control panel, integral printer, extended battery	CF30002GPGB
4 Loop control panel	CF30004G
4 Loop control panel, integral printer	CF30004GP
4 Loop control panel, extended battery	CF30004GEB
4 Loop control panel, integral printer, extended battery	CF30004GPGB
Add to end of product code if network card required	NC
Touch-screen repeater panel	CTPR3000
Passive repeater panel	CF3000PRG
Hinged protective cover kit	CF3000COV
Network kit (for retro fit)	DF6000NETKIT
Fire alarm system log book	MFALOG