



UTV & ATV Armor Kit Installation Tips

Thank for your purchase of this Ricochet Off-Road Armor Kit. All of our kits are custom designed to fit each model and should install hassle free with no additional modifications required. Please carefully read through all included instruction sheets before beginning your install.

The tips described on this sheet are general mounting tips that may or may not apply to your particular model, refer to the attached model specific instructions for a step by step mounting procedure.

If you do encounter a problem during installation please check the FAQ on our website or feel free to contact us by phone or email using the contact info at the bottom of this page.

Required Tools:

(refer to your hardware placement guide for bolt sizes)

Button Head TORX Bolts: (socket bit is highly recommended)

8mm bolts use a T-40 TORX bit

6mm bolts use a T-30 Torx bit

Hex Bolts & Nuts:

10mm bolts uses 17mm

8mm bolts uses 13mm

6mm bolts uses 10mm

1/4"-20 bolts uses 7/16"

Drill Bits:

While we try to avoid drilling whenever possible some models require one or two mounting points to be match drilled. When instructions call for a drilled mounting point use an **11/32"** bit to match drill through the mounting point on the skid plate only after the plate has been fully secured to your machine using the other hardware listed on your hardware guide.

Locking Nuts:

Most sets will include two types of locking nuts. Loose nuts are Nylock, and any nuts welded onto other hardware are pinch-style Stover lock nuts. It is highly recommended that you use a bit of Anti-seize or a drop of oil on the threads of the welded-on pinch style nuts, this will make the bolts go on and come off much easier.

Other helpful tips:

- Before you begin the installation organize all the included hardware according to the hardware placement sheet so you can quickly find the correct bolts and brackets when you need them.
- Install all bolts finger-tight at first until all hardware has been installed, this will give you maximum adjustability.
- When using the cupped washers to secure the plates to factory mounting points do not over torque the bolts because the threads can strip easily. If you do strip one out the simplest way to repair the thread is to use a 1/4"-20 x 5/8" self tapping bolt.
- You may find it easier to remove the rear tires when installing the rear a-arm guards, it's typically very tight and hard to see when the tires are left on.

Contact us at 1-866-273-1197 or dh_gibbs@comcast.net with any questions or concerns.

Arctic Cat Prowler Skid Plate Hardware List (P/N 7661)

Frame Skid Plates (p/n 737T,761M,761R,761FBA,761FBB):

- 34) #833 Cupped Washers
- 2) 1" Clamps
- 2) #700-06 Nut Plates
- 2) 8 x 25mm Flat Head Bolts
- 2) 8 x 25mm Button Head Bolts
- 2) 1/4" x 1" Hex Bolts
- 32) 1/4" x 1" Self Tapping Hex Bolts
- 4) 1/4" Flat Washers
- 2) 8mm Flat Washers

Front A-Arm Guards (p/n 737AFA,737AFB):

- 4) 3/4" Clamps
- 4) 8 x 20mm Button Head Bolts
- 4) 6 x 25mm Hex Bolts
- 4) 6mm Nylock Nuts
- 4) 8mm Flat Washers
- 8) 6mm Flat Washers

Rear A-Arm Guards (p/n 746ARA,746ARB):

- 4) 1 1/4" Clamps
- 4) 8 x 55mm Button Head Bolts
- 4) 8 x 20mm Button Head Bolts
- 8) 8mm Flat Washers
- 4) 8mm HD Flat Washers (larger ones)
- 4) 8mm Nylock Nuts

Arctic Cat Prowler Skid Plate Installation Instructions (P/N 7661)

Before you begin you will need:

A hand held Drill, a #7 (or 13/64" bit), a 5/16" Bit, a T-30 and a T-40 TORX wrench or socket, a 4mm and 5mm Allen wrench or socket, and a 7/16" and a 13mm Hex wrench or socket.

*if you are only installing a-arm guards you may skip down to step 6

1. Begin by removing all stock skid plates including the two metal plates which angle up on either side. A T-30 Torx bit is required to remove most of these bolts.
2. Refer to the hardware installation guide to determine where each type of mounting hardware is to be used. Locate the 1" round clamps and #700-06 Nut plates and pair with the appropriate type of bolt.
3. Use the #7 or 13/64" bit to open up each mounting point on the main frame where self tapping bolts will be used. DO NOT SUBSTITUTE ANY OTHER SIZE BITS IN THESE POSITIONS.
4. If you are installing A-arm guards use the 5/16" bit to open up the two outer mounting points on each of the front A-Arm Guards. Also use this 5/16" bit to drill through the plastic to access the mounting holes used for the front skid (p/n 737T). You can locate these points by holding the skid plate in place, lining up the two center mounting points with the existing mounting points on the frame. Mark the center of the two front mounting points on the plastic and drill through in that location. See hardware placement guide.
5. Now you may begin installing the skid plates. It doesn't really matter in which order you install the plates but make sure you leave everything loose at first so that the positions of each plate can be adjusted to create seamless transitions between plates. You will find it more convenient to prepare all your bolts first. Feed each bolt with a washer through one of the gold cupped washers. Also for this step you will find it much easier to have a helping hand to hold the plates in position while you get the first few bolts started. You will need to apply a fair amount of pressure on the self-tappers to get them started, just make sure they are threading straight in and not at an angle. For the standard hex bolts use a nylock nut and a flat washer on the back side. In the two positions where the 1" clamps are used it's best to hang them from the frame before putting the plate in place and then use the access holes to position it correctly to feed in the 8 x 25mm button head bolts. Use the #700-06 nut plates with the 8 x 20mm Flat head bolts in the countersunk mounting points on the rear of the center skid plate. Place the nut plates flat on the cross member behind the two 1" holes and feed the flat head into the nut. Again do not tighten the bolts down until they are all in place. When you are ready to begin tightening everything down make sure the plates are butted right up against one another. **It is very important not to over torque the self-tappers.** Torque these down to the point that they feel tight but without using too much strength.
6. Now if you have a-arm guards refer to the hardware placement guide to find the appropriate hardware. If you haven't already drilled out the stock mounting points you should do this now. They need to be drilled out to 5/16". Hold the guard up into place and install all of the required hardware leaving everything loose at first. On the rear guard where the 8 x 50mm button head is used make sure you feed the bolt in through the bottom side so the rounded button head is exposed rather than the nut. As you begin tightening down each bolt you will need to make sure the guard is pressed firmly against the a-arm. It is easiest to have someone else help hold the plate in place as you tighten or if necessary use something to keep it pressed firmly against the a-arm. A car jack works well for this.
7. If you have any questions or concerns feel free to call us at 1-866-273-1197

Clamp & Hardware Placement Guide for P/N 7661

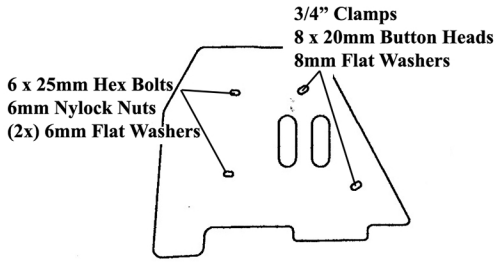

P/N 737AFA

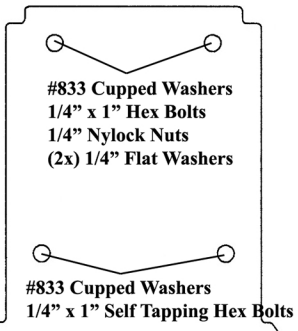

P/N 737T

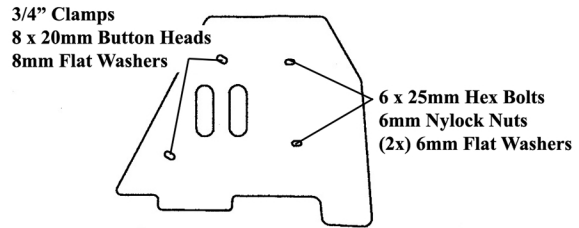

P/N 737AFB

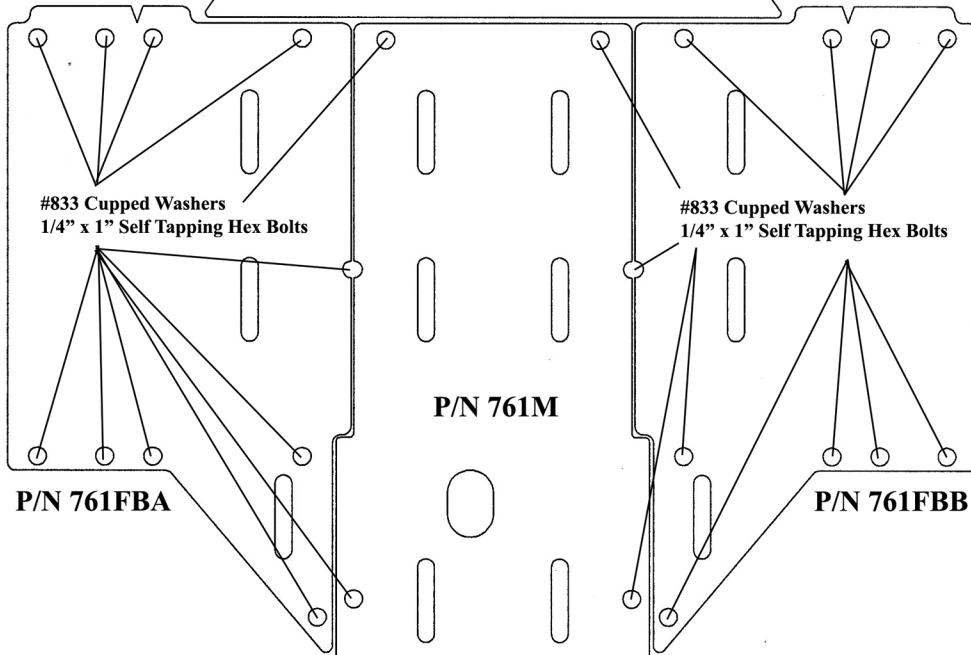
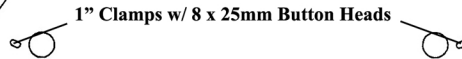

P/N 761M

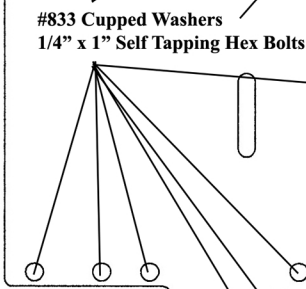

P/N 761FBA

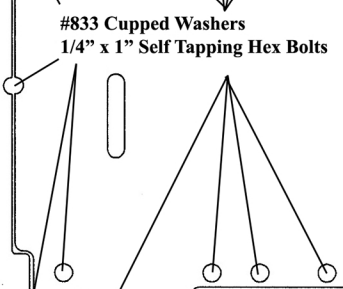

P/N 761FBB

8 x 55mm Button Head Bolts
std. 8mm Flat Washers
HD 8mm Flat Washers
8mm Nylock Nuts
(smaller washer goes on bolt side,
larger washer goes on nut side)

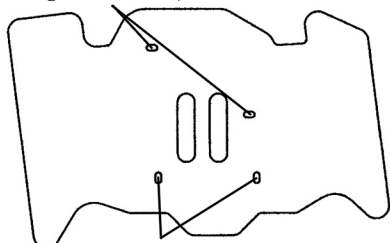

P/N 746ARA

8 x 25mm Flat Head Bolts
#700-06 Nut Plates



P/N 761R

8 x 55mm Button Head Bolts
std. 8mm Flat Washers
HD 8mm Flat Washers
8mm Nylock Nuts
(smaller washer goes on bolt side,
larger washer goes on nut side)

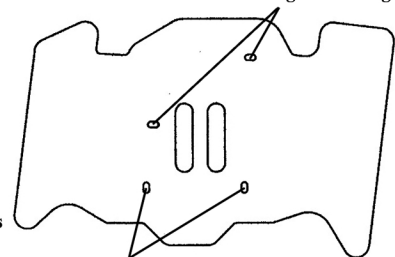

P/N 746ARB