

Craft Brew 200 GPD Reverse Osmosis Brewing System



**For Questions or Service
Call Us 805-777-7037**

[For Filters Click Here](#)



For questions, visit www.craftbrew.com
Or call 805-777-7037
©2014 Craft Brew Water Purification

This Pages Is Intentionally Blank

Table of Contents

INFORMATION TYPE	PAGE
INTRODUCTION	5
DESIGN PARAMETERS	5
SYSTEM INFORMATION	6
CRAFT BREW 200 GPD SYSTEM IDENTIFICATION	7
COMPONENT DESCRIPTION	7
INSTALLATION GUIDELINES	9
PURGING AND INITIAL START-UP	11
OPERATING DO's AND DON'Ts	12
RO SHUT-DOWN PROCEDURE	12
OPERATION LOG	13
TEMPERATURE CORRECTION SHEET	14
TEMPERATURE CORRECTION FORMULA	15
MAINTENANCE	16
REPLACING FILTER CARTRIDGES	16
MEMBRANE INSTALLATION, REMOVAL AND REPLACEMENT	17
REPLACING THE MEMBRANE ELEMENT	18
PREPARING UNIT FOR STORAGE OR SHIPMENT	19
TROUBLESHOOTING	20
MANUFACTURER'S LITERATURE AND DRAWINGS	21



PLEASE READ THE ENTIRE MANUAL BEFORE PROCEEDING WITH THE INSTALLATION AND STARTUP. YOUR FAILURE TO FOLLOW ANY ATTACHED INSTRUCTIONS OR OPERATING PARAMETERS MAY LEED TO THE PRODUCT'S FAILURE, WHICH CAN CAUSE PROPERTY DAMAGE AND/OR PERSONAL INJURY.

- DO NOT USE WHERE THE WATER IS MICROBIOLOGICALLY UNSAFE OR OF UNKNOWN QUALITY WITHOUT ADEQUATE DISINFECTION BEFORE OR AFTER THE SYSTEM.
- PRETREATMENT MUST BE SUFFICIENT TO ELIMINATE THE POSSIBILITY OF PREMATURE FOULING.
- ALWAYS TURN OFF THE UNIT, SHUT OFF THE FEED WATER, AND DISCONNECT THE ELECTRICAL POWER WHEN WORKING ON THE UNIT.
- NEVER ALLOW THE PUMP TO RUN DRY.
- NEVER START THE PUMP WITH THE CONCENTRATE VALVE CLOSED.
- NEVER ALLOW THE UNIT TO FREEZE OR OPERATE WITH A FEED WATER TEMPERATURE ABOVE 85°F

INTRODUCTION

The Craft Brew 200 GPD Reverse Osmosis System is a water purification unit capable of providing potable water. This unit has been designed to reduce contaminants and impurities in the water utilizing reverse osmosis technology. Water sources can include tap and brackish water. The construction of this unit has been engineered for durability and continuous use.

DESIGN PARAMETERS

Typical operating conditions and general system descriptions are provided within the table on the following page.

Since each water purification application differs by location, it is important to contact your equipment dealer or service provider regarding specific settings appropriate to operating the reverse osmosis system consistent with the temperature and quality of your feed water source.

Information regarding the calculation of recovery and rejection and correction for differences in feed water temperature is provided within this manual.

Reminders:

- Do not exceed recommended permeate flow.
- System pressure is variable due to water conditions.
- Permeate flow will increase at a higher temperature and will decrease at a lower temperature.

SYSTEM INFORMATION

Craft Brew 200 GPD Specifications	
Design	
Configuration	Single Pass
Feed Water Source ***	TDS < 1000
Standard Recovery Rate †	40%
Rejection and Flow Rates	
Nominal Salt Rejection %	98.5
Permeate Flow* GPM (LPM)	0.14 (0.53)
Minimum Concentrate Flow GPM (LPM)	0.21 (0.79)
Connections	
Feed (In)	3/8 Tubing
Permeated (In)	3/8 Tubing
Concentrated (In)	3/8 Tubing
Membranes	
Membranes Membrane(s) Per Vessel	1
Membrane Quantity	1
Membrane Size	2514
Vessels	
Vessel Array	1
Vessel Quantity	1
Standard Pump	
Pump Type	Aquatec 8800
Electrical	
Standard Voltage	110V, 60Hz, 1 PH, 1.0A
System Dimensions and Weight	
L x W x H (in / cm)	9 x 20 x 19 (22.9 x 50.8 x 48.3)
Weight (lb / kg)	42 (19.1)

***Product flow and recovery rates are based on feedwater conditions of 550 ppm TDS at 77°F and 60psi. Treatment ability of the RO system is dependent on feed water quality. Higher TDS and/or lower temperatures will reduce product flow. Performance projections should be run for each installation.**

CRAFT BREW 200 GPD SYSTEM INFORMATION

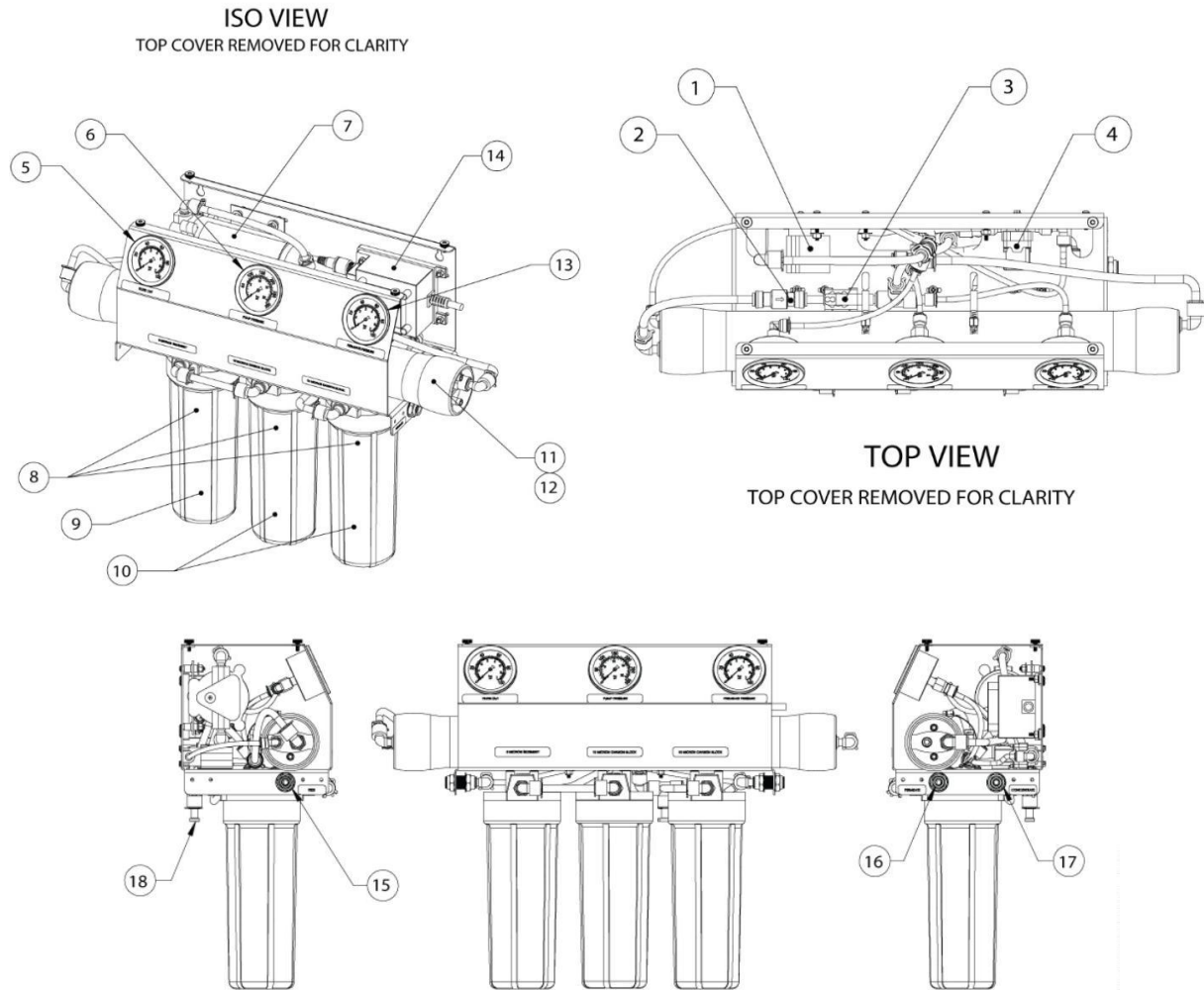

COMPONENT DESCRIPTIONS

1. **Flow Restrictor** – Valve on concentrate line to regulate system recovery.
2. **Check Valve** – Valve on permeate line to prevent membrane delamination.
3. **Pressure Switch** – Turns off system when product pressure reaches 40 psi and turns system on at 20 psi.
4. **Solenoid Valve** – System inlet valve. Opens when system is in operation, closes when product tank is full, or system is in non-operational mode.
5. **Filter Out Gauge** – Measures the feed water pressure in the system.
6. **Pump Pressure Gauge** – Measures system pressure on outlet of pump.
7. **R.O. Pump** – Supplies osmotic pressure necessary for reverse osmosis.

COMPONENT DESCRIPTIONS (CONTINUED)

8. **Filter Housings** – Housings for 5-micron sediment and 10 micron carbon filters.
9. **5 Micron Sediment Filter** – Filters out suspended solids larger than 5 microns in the feed water to the system.
10. **10 Micron Carbon Block Filter** - Filters out free chlorine, improves taste and odor.
11. **Membrane Housing** – Houses reverse osmosis membrane.
12. **Membrane** – Reverse osmosis membrane filters out dissolved solids (TDS) to produce permeate.
13. **Permeate Pressure Gauge** – Measures the permeate pressure.
14. **Transformer** – Transforms incoming voltage to 24VAC to power R.O. motor/pump and system.
15. **Feed Connection Port** – 3/8" Quick Connect. Connect the feed source to this line.
16. **Permeate Connection Port** – 3/8" Quick Connect. Connect this line to end use.
17. **Concentrate Connection Port** – 3/8" Quick Connect. Connect this to line drain.
18. **Tank Connection Port** – 3/8" Quick Connect. Connect this line to the product water bladder tank.

INSTALLATION GUIDELINES

1. Inspect the system for any damage that could have occurred during shipment. Although the system has been individually inspected, complete a quick inspection of the fittings, tubing and other components.
2. Please provide a reasonable amount of space for installation and leave 6 inches of space below the filter housings for ease of maintenance.



NOTE: THE REVERSE OSMOSIS SYSTEM SHOULD BE INSTALLED INDOORS AND IT IS SUGGESTED THAT IT NOT BE IN DIRECT SUNLIGHT OR EXTREME COLD.

3. Connect the 3/8" tube fitting to an incoming water source. The minimum inlet water pressure should be at least 30 psi. The system's minimum operating pressure is 80 psi, but the optimum operating pressure is 100 psi.



NOTE: DO NOT OPERATE AT A PRESSURE EXCEEDING 120 PSI. THE OPERATING PRESSURE CAN BE INCREASED ON THE FACE OF THE BOOSTER PUMP BY TURNING THE HEX SCREW CLOCKWISE.

4. Connect the concentrate 3/8" tubing (waste) line to drain.
5. This system has been designed with an auto-flush restrictor. This restrictor automatically flushes the reverse osmosis system for 30 seconds every time it starts up and once every hour when the system is producing water.
6. This system has been designed to operate together with an external bladder tank. Connect 3/8" tubing line to "TANK" port on the back of the systems.



NOTE: THE TANK PRESSURE SWITCH WILL SHUT THE SYSTEM OFF AUTOMATICALLY WHEN THE BLADDER TANK IS FULL.

INSTALLATION GUIDELINES (CONTINUED)

7. The sediment filter and carbon must be serviced regularly for optimal performance. The filters and water quality should be checked every two weeks minimum.
8. Dispose of the product water until the conductivity of the product water reaches your desired level. Use any TDS or conductivity meter to monitor the product water quality. A minimum quality of 96% NaCl rejection is recommended.



NOTE: ANY CHLORINE EXPOSURE WILL DAMAGE THE MEMBRANE PERMANENTLY.

9. This system has been factory wired and preset with a pressure switch at 20-40 psi, which is only to be used with a pressurized bladder tank. If using an atmospheric storage tank, a float switch will be required to turn the system on and off.

PURGING AND INITIAL STARTUP

1. Direct the permeate water line to drain.
2. Feed the 3/8" QC inlet with source water at 40-60 psi.
3. Plug system into electrical outlet.
4. Run system while permeate and concentrate lines feed to the drain for 20-30 minutes to flush out preservative and any trapped air.
5. After 20-30 minutes, shut down the system and re-direct the permeate line back to final use location (i.e., faucet).
6. Your start up is now complete. Make sure that the system pressures and flows are matching up with that of your specific system model, located on the System Information (pg. 6) of this manual. Record the readings daily for a week and after a week record the readings once a week. This will assist you to determine when component maintenance and/or replacement is necessary.

OPERATING DO's AND DON'Ts

DO:

- Change the cartridge filters regularly.
- Monitor the system and keep a daily log.
- Run the system, as much as possible on a continuous basis.
- Adjust the system recovery to the recommended value.
- Always feed the pump with filtered water.

DON'T:

- Permit chlorine to enter or be present in the feed water.
- Shut down the system for extended periods.
- Close the throttle valve completely.
- Operate the system with insufficient feed flow.
- Operate the pump dry.

RO SHUT-DOWN PROCEDURE

1. Unplug the system power cord from the wall.
2. Turn off feed supply water from system.
3. Purge the system. See Purging and Initial Startup instructions on previous page. (Page 11)
4. If the reverse osmosis unit is to be shut down for an extended period, a membrane preservative should be used to preserve the membranes. See Preparing Unit for Storage or Shipment instructions. (Page 19)
5. When the unit is ready to restart please follow the initial startup procedures. The permeate line should be diverted to drain for 30 minutes. (Page 11)

OPERATING LOG

Company Name

Day of Startup

Location

Date of Last Cleaning

Week Of

System Serial Number

Date					
Time					
Hour of Operation					
Filter Inlet Pressure (PSI)					
Filter Outlet Pressure (PSI)					
Concentrate Pressure (PSI)					
Pump Discharge Pressure (PSI)					
Feed Flow (GPM)					
Permeate Flow (GPM)					
Concentrate Flow (GPM)					
Recycle Flow (GPM)					
Recovery %					
Feed Temperature					
Feed TDS (PPM)					
Permeate TDS (PPM)					
Rejection %					
Feed pH					
Permeate pH					
Scale Inhibitor Feed (PPM)					
Iron (mg/L)					
Free Chlorine (mg/L)					
Hardness (GPG CaCO³)					

TEMPERATURE CORRECTION SHEET

Find the temperature correction factor (TCF) from the table below. Divide the rated permeate flow at 77°F by the temperature correction factor. The result is the permeate flow at the desired temperature. See example on the next page.

Temperature °F (°C)	Temperature Correction Factor	Temperature °F (°C)	Temperature Correction Factor	Temperature °F (°C)	Temperature Correction Factor	Temperature °F (°C)	Temperature Correction Factor	Temperature °F (°C)	Temperature Correction Factor
50.0 (10.0)	1.711	57.2 (14.0)	1.475	64.4 (18.0)	1.276	71.6 (22)	1.109	78.8 (26)	0.971
50.2 (10.1)	1.705	57.4 (14.1)	1.469	64.6 (18.1)	1.272	71.8 (22.1)	1.105	79.0 (26.1)	0.968
50.4 (10.2)	1.698	57.6 (14.2)	1.464	64.8 (18.2)	1.267	72.0 (22.2)	1.101	79.2 (26.2)	0.965
50.5 (10.3)	1.692	57.7 (14.3)	1.459	64.9 (18.3)	1.262	72.1 (22.3)	1.097	79.3 (26.3)	0.962
50.7 (10.4)	1.686	57.9 (14.4)	1.453	65.1 (18.4)	1.258	72.3 (22.4)	1.093	79.5 (26.4)	0.959
50.9 (10.5)	1.679	58.1 (14.5)	1.448	65.3 (18.5)	1.254	72.5 (22.5)	1.09	79.7 (26.5)	0.957
51.1 (10.6)	1.673	58.3 (14.6)	1.443	65.5 (18.6)	1.249	72.7 (22.6)	1.086	79.9 (26.6)	0.954
51.3 (10.7)	1.667	58.5 (14.7)	1.437	65.7 (18.7)	1.245	72.9 (22.7)	1.082	80.1 (26.7)	0.951
51.4 (10.8)	1.66	58.6 (14.8)	1.432	65.8 (18.8)	1.24	73.0 (22.8)	1.078	80.2 (26.8)	0.948
51.6 (10.9)	1.654	58.8 (14.9)	1.427	66.0 (18.9)	1.236	73.2 (22.9)	1.075	80.4 (26.9)	0.945
51.8 (11.0)	1.648	59.0 (15.0)	1.422	66.2 (19.0)	1.232	73.4 (23.0)	1.071	80.6 (27.0)	0.943
52.0 (11.1)	1.642	59.2 (15.1)	1.417	66.4 (19.1)	1.227	73.6 (23.1)	1.067	80.8 (27.1)	0.94
52.2 (11.2)	1.636	59.4 (15.2)	1.411	66.6 (19.2)	1.223	73.8 (23.2)	1.064	81.0 (27.2)	0.937
52.3 (11.3)	1.63	59.5 (15.3)	1.406	66.7 (19.3)	1.219	73.9 (23.3)	1.06	81.1 (27.3)	0.934
52.5 (11.4)	1.624	59.7 (15.4)	1.401	66.9 (19.4)	1.214	74.1 (23.4)	1.056	81.3 (27.4)	0.932
52.7 (11.5)	1.618	59.9 (15.5)	1.396	67.1 (19.5)	1.21	74.3 (23.5)	1.053	81.5 (27.5)	0.929
52.9 (11.6)	1.611	60.1 (15.6)	1.391	67.3 (19.6)	1.206	74.5 (23.6)	1.049	81.7 (27.6)	0.926
53.1 (11.7)	1.605	60.3 (15.7)	1.386	67.5 (19.7)	1.201	74.7 (23.7)	1.045	81.9 (27.7)	0.924
53.2 (11.8)	1.6	60.4 (15.8)	1.381	67.6 (19.8)	1.197	74.8 (23.8)	1.042	82.0 (27.8)	0.921
53.4 (11.9)	1.594	60.6 (15.9)	1.376	67.8 (19.9)	1.193	75.0 (23.9)	1.038	82.2 (27.9)	0.918
53.6 (12.0)	1.588	60.8 (16.0)	1.371	68.0 (20.0)	1.189	75.2 (24.0)	1.035	82.4 (28.0)	0.915
53.8 (12.1)	1.582	61.0 (16.1)	1.366	68.2 (20.1)	1.185	75.4 (24.1)	1.031	82.6 (28.1)	0.913
54.0 (12.2)	1.576	61.2 (16.2)	1.361	68.4 (20.2)	1.18	75.6 (24.2)	1.028	82.8 (28.2)	0.91
54.1 (12.3)	1.57	61.3 (16.3)	1.356	68.5 (20.3)	1.176	75.7 (24.3)	1.024	82.9 (28.3)	0.908
54.3 (12.4)	1.564	61.5 (16.4)	1.351	68.7 (20.4)	1.172	75.9 (24.4)	1.021	83.1 (28.4)	0.905
54.5 (12.5)	1.558	61.7 (16.5)	1.347	68.9 (20.5)	1.168	76.1 (24.5)	1.017	83.3 (28.5)	0.902
54.7 (12.6)	1.553	61.9 (16.6)	1.342	69.1 (20.6)	1.164	76.3 (24.6)	1.014	83.5 (28.6)	0.9
54.9 (12.7)	1.547	62.1 (16.7)	1.337	69.3 (20.7)	1.16	76.5 (24.7)	1.01	83.7 (28.7)	0.897
55.0 (12.8)	1.541	62.2 (16.8)	1.332	69.4 (20.8)	1.156	76.6 (24.8)	1.007	83.8 (28.8)	0.894
55.2 (12.9)	1.536	62.4 (16.9)	1.327	69.6 (20.9)	1.152	76.8 (24.9)	1.003	84.0 (28.9)	0.892
55.4 (13.0)	1.53	62.6 (17.0)	1.323	69.8 (21.0)	1.148	77.0 (25.0)	1	84.2 (29.0)	0.889
55.6 (13.1)	1.524	62.8 (17.1)	1.318	70.0 (21.1)	1.144	77.2 (25.1)	0.997	84.4 (29.1)	0.887
55.8 (13.2)	1.519	63.0 (17.2)	1.313	70.2 (21.2)	1.14	77.4 (25.2)	0.994	84.6 (29.2)	0.884
55.9 (13.3)	1.513	63.1 (17.3)	1.308	70.3 (21.3)	1.136	77.5 (25.3)	0.991	84.7 (29.3)	0.882
56.1 (13.4)	1.508	63.3 (17.4)	1.304	70.5 (21.4)	1.132	77.7 (25.4)	0.988	84.9 (29.4)	0.879
56.3 (13.5)	1.502	63.5 (17.5)	1.299	70.7 (21.5)	1.128	77.9 (25.5)	0.985	85.1 (29.5)	0.877
56.5 (13.6)	1.496	63.7 (17.6)	1.294	70.9 (21.6)	1.124	78.1 (25.6)	0.982	85.3 (29.6)	0.874
56.7 (13.7)	1.491	63.9 (17.7)	1.29	71.1 (21.7)	1.12	78.3 (25.7)	0.979	85.5 (29.7)	0.871
56.8 (13.8)	1.486	64.0 (17.8)	1.285	71.2 (21.8)	1.116	78.4 (25.8)	0.977	85.6 (29.8)	0.869
57.0 (13.9)	1.48	64.2 (17.9)	1.281	71.4 (21.9)	1.112	78.6 (25.9)	0.974	85.8 (29.9)	0.866

TEMPERATURE CORRECTION FORMULA

25 gpm @ 59°F (25÷1.42=17.60 gpm)

25 gpm @ 77°F (25÷1=25 gpm)

25 gpm @ 84°F (25÷0.89=28.08 gpm)

REJECTION FORMULA:

The amount of total dissolved solids (TDS) rejected by the membrane is expressed as a percentage. For example, a 99.5% rejection rate means that 99.5% of total dissolved solids do not pass through the membrane. To calculate the % rejection, use the following formula:

$$\begin{aligned}\% \text{Rejection} &= [(\text{Feed TDS} - \text{Product TDS}) / \text{Feed TDS}] \times 100 \\ 99.5\% &= [(10000 - 8.25) / 10000] \times 100\end{aligned}$$

NOTE: ALL TDS FIGURES MUST BE EXPRESSED IN THE SAME UNITS, TYPICALLY PARTS PER MILLION (PPM) OR MILLIGRAMS PER LITER (MG/L).

RECOVERY FORMULA:

The amount of permeate water recovered for use is expressed as a percentage. To calculate % recovery, use the following formula:

$$\begin{aligned}\% \text{Recovery} &= (\text{Product Water Flow Rate} / \text{Feed Water Flow Rate}) \times 100 \\ 75\% &= (60 / 80) \times 100\end{aligned}$$

NOTE: ALL FLOW RATES MUST BE EXPRESSED IN THE SAME UNITS, TYPICALLY GALLONS PER MINUTE (GPM).

MAINTENANCE

The performance of a reverse osmosis unit is influenced by the feed water composition, feed pressure, temperature and recovery. For example, a feed temperature drop of 4°C will cause a permeate flow decrease of about 10%. This, however, is a normal phenomenon.

In order to distinguish between such normal phenomena and performance changes due to fouling or problems, the measured permeate flow and salt passage must be normalized. Normalization is a comparison of the actual performance to a given reference performance while the influences of operating parameters are considered. The reference performance may be the designed performance or the measured initial performance.

Normalization with reference to the designed (or warranted) system performance is useful to verify that the system gives the specified (or warranted) performance. Normalization with reference to the initial system performance is useful to show up any performance changes between day one and the actual date.

System performance normalization is strongly recommended, because it allows an early identification of potential problems (e.g., scaling or fouling) when the normalized data are recorded daily. Corrective measures are much more effective when taken early.

REPLACING FILTER CARTRIDGES

The reverse osmosis unit uses 5-micron sediment filter cartridges that need to be replaced frequently. Change the sediment cartridges when the pressure gauge on the filter outlet of the filter housing indicates a pressure differential of 15 psi from that of the feed water supply.

[For Filters for the Craft Brew 200 Click Here](#)

1. Turn off and unplug reverse osmosis unit.
2. Turn off water supply to system.
3. Drain the product water tank. Make sure all pressure gauges read 0.
4. With a filter wrench, remove filter housing bottom.
5. Remove and discard the old filter cartridges.
6. Install new filter cartridges.
7. Re-assemble the filter housing.
8. Plug unit back in and turn on water supply to system inlet.
9. Turn on the RO unit and inspect filter housing for leaks.

MEMBRANE INSTALLATION, REMOVAL AND REPLACEMENT

Installation and replacing membranes in the membrane housings is an easy process if you have the proper information and tools at hand. Please refer to the following instructions when removing and replacing membrane elements:



WARNING: ALL PRESSURE GAUGES MUST READ ZERO BEFORE PROCEEDING. BEFORE ATTEMPTING, DISCONNECT THE POWER FROM THE SYSTEM AND BLEED ALL WATER PRESSURE FROM THE SYSTEM.

1. Remove the end cap from the right (feed water) side of the membrane housings. This is done by removing the two half-moon retaining disks using a #5 Allen wrench, the end plug should then freely slide out of the membrane housing.
2. Remove the membrane bag containing the membrane element from the shipping box. The membrane should be contained within a plastic oxygen barrier bag.



NOTE: WEAR GLOVES FOR THE FOLLOWING STEPS IN ORDER NOT TO CONTAMINATE THE MEMBRANE.

3. Cut the bag open as close as possible to the seal at one end of the bag, so the bag may be re-used if necessary.
4. Make sure that all parts are clean and free from dirt. Examine the brine seal and permeate tube for nicks or cuts. Replace the O-rings or brine seal if damaged.
5. Flow directions should be observed for installation of the membrane element into the pressure vessels.

REPLACING THE MEMBRANE ELEMENT



WARNING: THE BRINE SEAL MUST BE IN THE SAME POSITION AS IT WAS FOR FACTORY PRE-INSTALLED MEMBRANE ELEMENT. THE BRINE SEAL IS A RUBBER SEAL THAT PROTRUDES ON ONE SIDE OF THE MEMBRANE AND IS ALWAYS ON THE FEED SIDE OF THE MEMBRANE ELEMENT. THE BRINE SEAL SHOULD BE ON THE RIGHT SIDE OF THE MEMBRANE HOUSING.

1. Remove membrane element from the right (feed water) side of the membrane housing. Long nose pliers may be necessary to pull the old membrane element out of the membrane element housing.
2. Lubricate the brine seal and O-rings with a non-petroleum-based lubricant, such as Dow Corning® 111. Do not use a petroleum-based lubricant.
3. Install membrane through the right side (feed water) of the membrane housing with brine seal located on the feed water side.
4. With a smooth and constant motion, push the membrane element into the housing so the brine seal enters the housing without coming out of the brine seal groove.
5. Re-install the end plug on the right side by gently twisting the end cap, while pushing it onto the housing. Ensure that you do not pinch or fatigue any O-rings while re-installing the end plug. Push the end plug on until the outer diameter of the plug is flush with the outer diameter of the membrane housing.
6. Insert the two half-moon retaining disks until they are fully seated. Subsequently fasten using a #5 Allen wrench.
7. Reconnect any fittings that may have been disconnected when the membrane housings were disassembled.
8. To start-up the system, please refer to the Initial Start-Up section of this manual. (Page 11)



CAUTION: WET MEMBRANES ARE SHIPPED IN A PRESERVATIVE SOLUTION. THE MEMBRANES MUST BE FLUSHED FOR AT LEAST 30 MINUTES TO REMOVE THE PRESERVATIVE FROM THE MEMBRANE. DISCARD ALL OF THE PERMEATE, WHICH IS PRODUCED DURING THE FLUSH PERIOD.

PREPARING UNIT FOR STORAGE OR SHIPMENT

Prior to shipping or storing your system, the system should be cleaned with an appropriate cleaner, flushed with water, and protected from biological attack with an appropriate solution for membrane elements. The membrane housing(s) and plumbing lines of the system must be completely drained. Any water remaining in the plumbing of a system may freeze, causing serious damage.

PREPARING SYSTEM FOR STORAGE:

1. Totally immerse the elements in the membrane housing in a solution of 2% M-100, venting the air outside of the membrane housings. Use the overflow technique: circulate the M-100 solution in such a way that the remaining air in the system is minimized after the recirculation is completed. After the membrane housing is filled, the M-100 solution should be allowed to overflow through an opening located higher than the upper end of the highest membrane housing being filled.
2. Separate the preservation solution from the air outside by closing all valves. Any contact with oxygen will oxidize the M-100.
3. Check the pH once a week. When the pH becomes 3 or lower, change the preservation solution.
4. Repeat this process at least once a month.
5. During the shutdown period, the plant must be kept frost-free, or the temperature must not exceed 113°F (45°C).

PREPARING UNIT FOR SHIPMENT:

1. Disconnect the inlet, concentrate, and permeate plumbing.
2. Drain all water from the pre-filter cartridge housings by unscrewing the housings, removing the pre-filter cartridges, and drain the water from the housings.
3. Disconnect the tubing from the connectors on the permeate and concentrate inlets and outlets.
4. Fully open the concentrate valve.
5. Allow the system to drain for a minimum of eight hours or until the opened ports quit dripping.
6. After draining is complete, reconnect all the plumbing.

TROUBLESHOOTING

SYMPTOMS	POSSIBLE CAUSES	CORRECTIVE ACTION
Low Inlet Pressure	Low Supply Pressure	Increase Inlet Pressure
	Cartridge Filters Plugged	Change Filters
	Solenoid Valve Malfunction	Replace Sol. Valve and/or Coil
	Motor May Not Be Drawing Correct Current	Use Clamp-On Amp Meter To Check The Motor Amp Draw.
	Concentrate Valve Might Be Damaged	Replace Needle Valve
	Leaks	Fix Any Visible Leaks
Low Permeate Flow	Low Inlet Flow	Adjust Concentrate Valve
	Cold Feed Water	See Temperature Correction Sheet
	Low Operating Pressure	See Low Inlet Pressure
	Defective Membrane Brine Seal	Inspect And/Or Replace Brine seal
	Fouled Or Scaled Membrane	Clean The Membranes
High Permeate Flow	Damaged Product Tube O-Rings	Inspect And/Or Replace
	Damaged Or Oxidized Membrane	Replace Membrane
	Exceeding Maximum Feed Water Temperature	See Temperature Correction Sheet
Poor Permeate Quality	Low Operating Pressure	See Low Inlet Pressure
	Damage Product Tube O-Rings	Inspect And/Or Replace
	Damaged Or Oxidized Membrane	Replace Membrane
Membrane Fouling	Metal Oxide Fouling	Improve pretreatment to remove metals. Clean with Acid Cleaners.
	Colloidal Fouling	Optimize pretreatment for colloid removal. Clean with high pH anionic cleaners.
	Scaling (CaSO ₄ , CaSO ₃ , BaSO ₄ , SiO ₂)	Increase acid addition and antiscalant dosage for CaVO ₃ and CaCO ₄ . Reduce recovery. Clean with Acid Cleaners.
	Biological Fouling	Shock dosage of Sodium Bi-Sulfate. Continuous feed of Sodium Bi-Sulfate at reduced pH. Chlorination and de-chlorination. Replace cartridge filters.
	Organic Fouling	Activated Carbon or other pretreatment. Clean with high pH cleaner.
	Chlorine Oxidation	Check Chlorine feed equipment and de-chlorination system.
	Abrasion of membrane by Crystalline Material	Improve pretreatment. Check all filters for media leakage.

MANUFACTURER'S
LITERATURE AND DRAWINGS

SYSTEM DRAWING

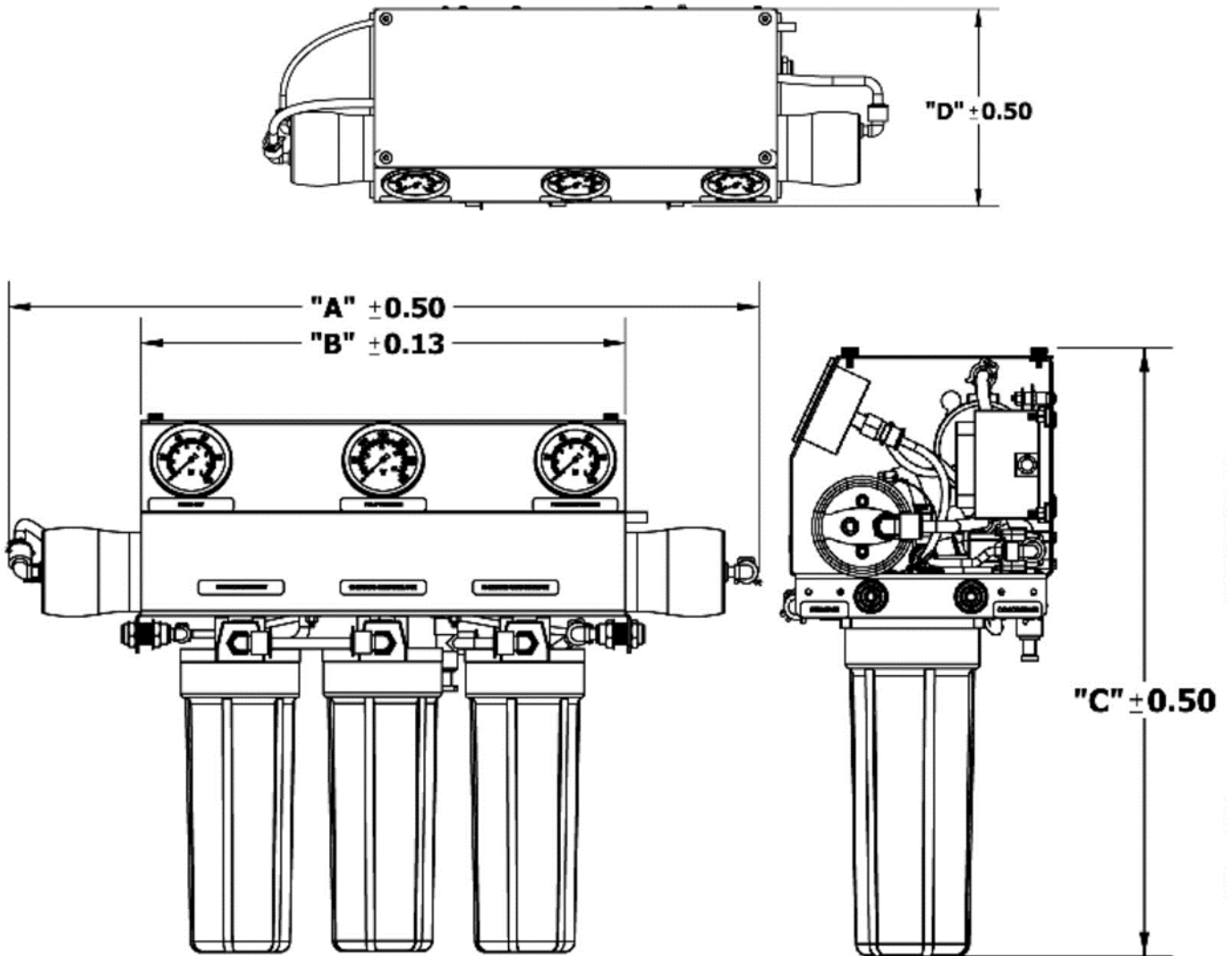

Dimensions	Craft Brew 200 GDP
"A" DIM	19.33
"B" DIM	17.00
"C" DIM	18.92
"D" DIM	8.34
Dry Weight	55 lbs.

CRAFT BREW 200 GDP FLOW DIAGRAM

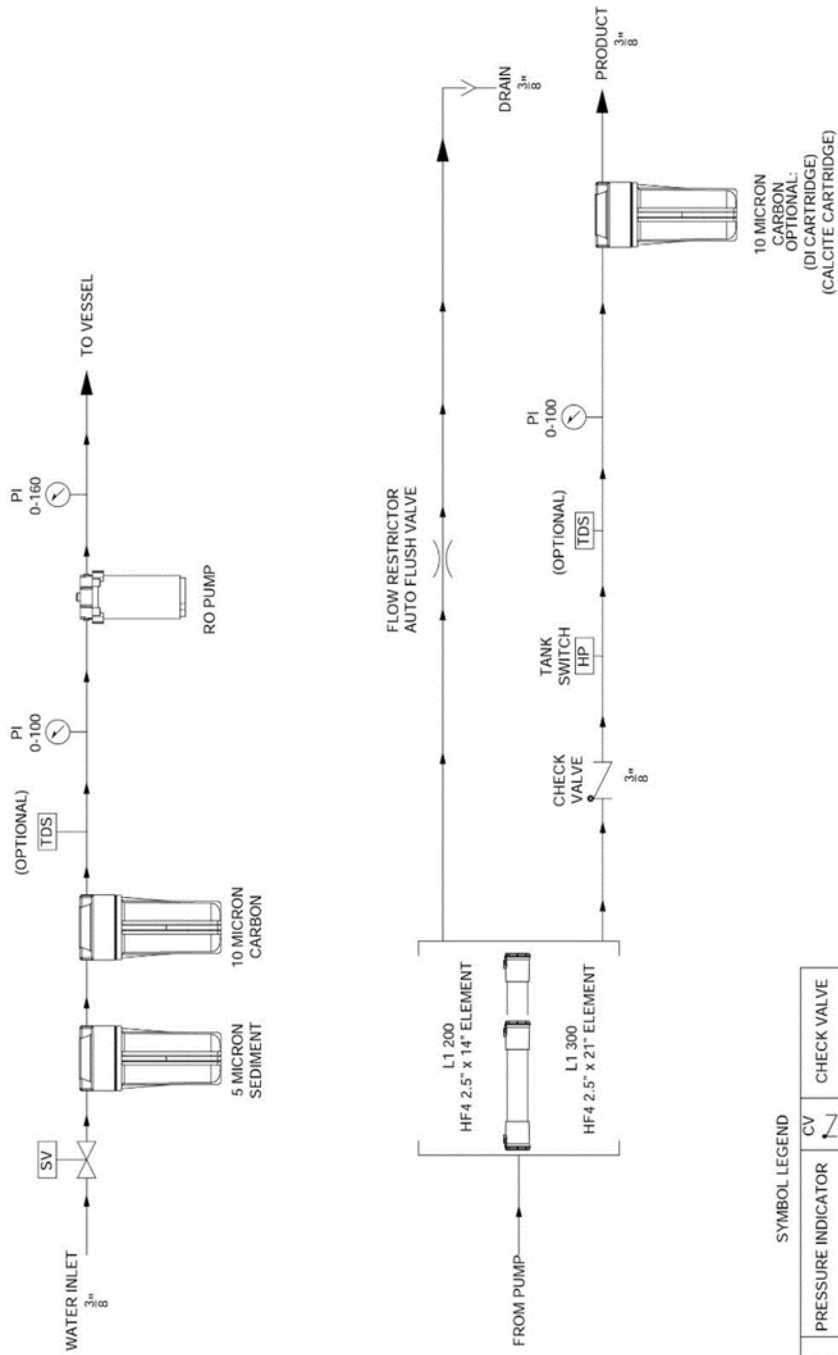

SYMBOL LEGEND

PI	PRESSURE INDICATOR	CV	CHECK VALVE
[HP]	SOLENOID	[HP]	TANK SWITCH
[TDS]	FLOW RESTRICTOR AUTO FLUSH VALVE	[TDS]	TDS MONITOR

CRAFT BREW 200 GPD WIRING DIAGRAM

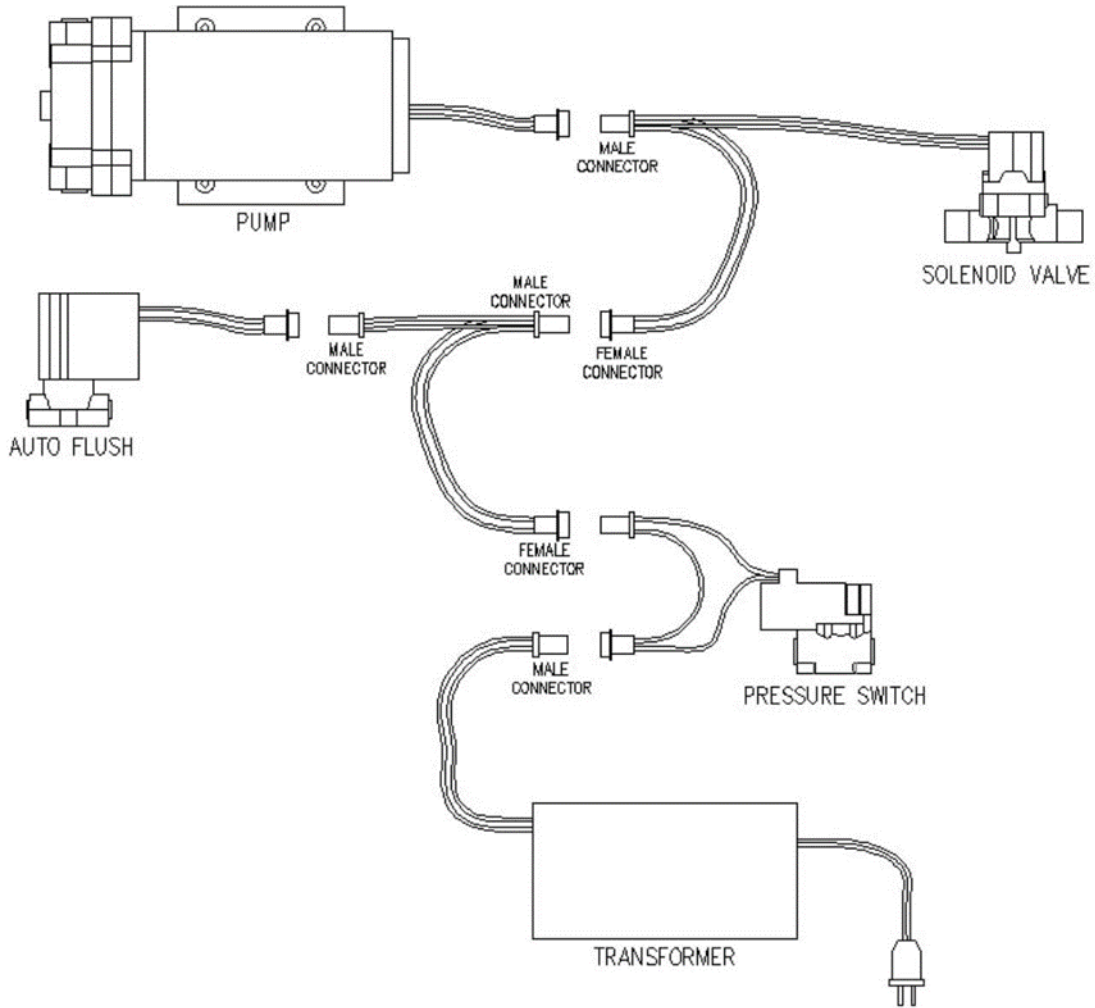

∨

CRAFT BREW 200 GDP

ELECTRICAL SCHEMATIC 110V/50-60HZ

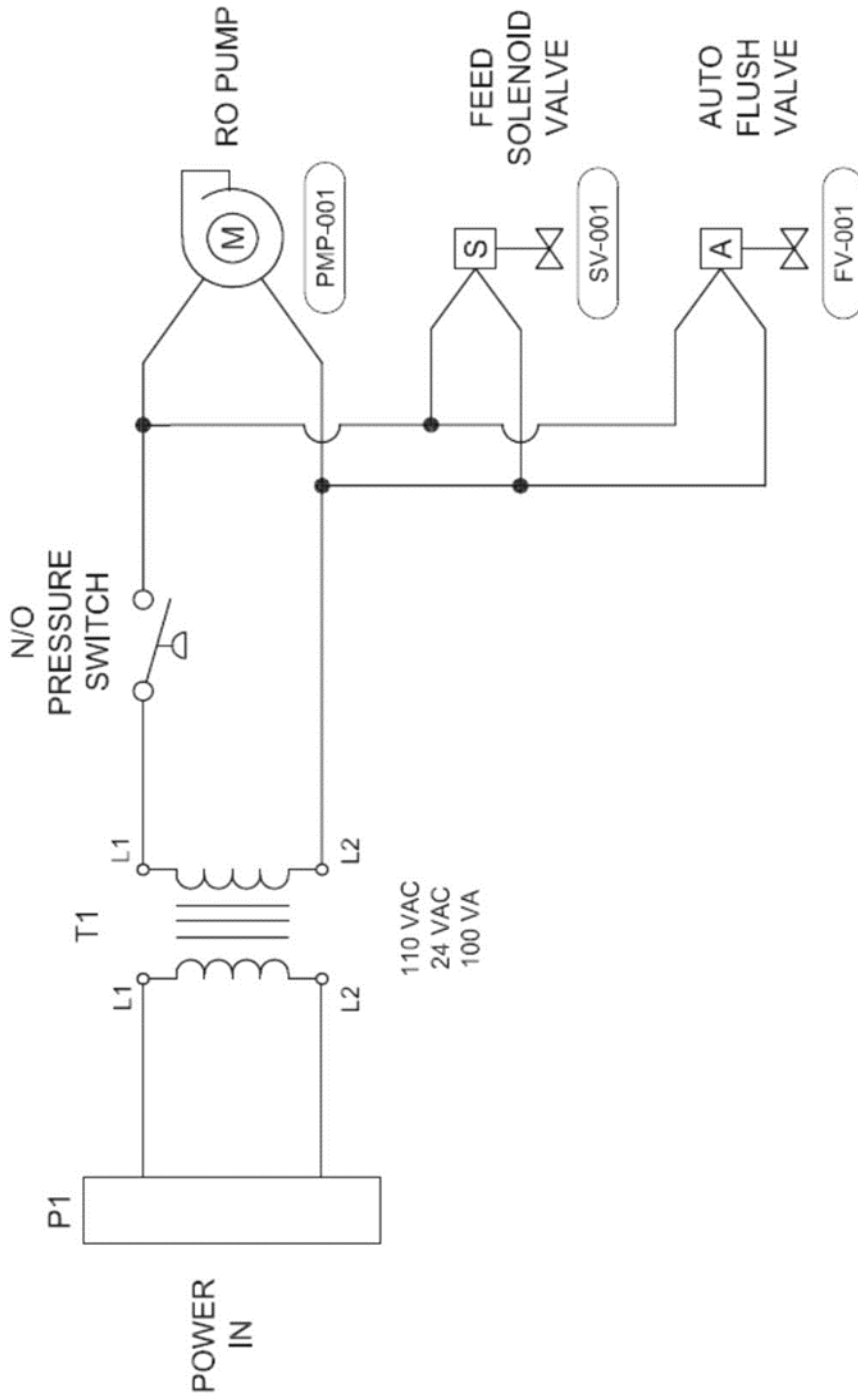

System Warranty

One-Year Limited Warranty

Warranty Terms

Subject to the terms and conditions set forth hereinafter, manufacturer warrants to the original purchaser (hereafter the “Customer”) that the systems and products manufactured by manufacturer are free from defects in material and in workmanship for twelve (12) months from the Warranty Commencement Date (as defined below) only when used strictly in accordance with the applicable operating instructions and within the range of the operating conditions specified by manufacturer for each such product.

This Warranty does not extend to systems, equipment, or components manufactured by others, nor to systems, equipment, or components manufactured by others and distributed by manufacturer. This Warranty does not extend to equipment or components manufactured by others which have been incorporated into a manufacturer product but, if allowable, manufacturer hereby assigns, without warranty, to the Customer its interest, if any, under any warranty made by the manufacturer of such equipment or component. This Warranty does not cover disposable items such as fuses, O-rings, regeneration materials/chemicals, or other such disposable items, which must be replaced periodically under the normal and foreseeable operating conditions of the goods warranted hereby.

Warranty Commencement Date

The Warranty Commencement Date for each manufacturer product shall be the later of the date of: (1) receipt by the Customer, or (2) the date of installation at the Customer’s premises provided that such installation must occur within three (3) months of shipment from the manufacturer’s manufacturing facility in California. In no event shall the Warranty Commencement Date exceed three (3) months from the shipment from manufacturer’s manufacturing facility. The Customer shall provide proof of purchase in order to exercise rights granted under this Warranty. If requested by manufacturer, the Customer must also provide proof of the installation date. Proof of installation shall be returned by Customer to manufacturer within thirty (30) days after installation by virtue of supplying a Warranty Validation Card supplied with each manufacturer product fully completed and signed in ink by Customer and the authorized installer of the product.

Warranty Service

MANUFACTURER’S OBLIGATION UNDER THIS WARRANTY IS LIMITED TO THE REPAIR OR REPLACEMENT (AT MANUFACTURER’S SOLE DISCRETION) OF ANY PRODUCT, OR COMPONENT THEREOF, PROVED TO BE DEFECTIVE IN MATERIAL OR WORKMANSHIP WITHIN THE COVERED WARRANTY PERIOD.

The Customer, at the Customer's risk and expense, shall be responsible for returning such product or component, only after obtaining a Return Goods Authorization (RGA) number from manufacturer, arranging for freight prepaid, and in conformance with any special packaging and shipping instructions set forth on the operation documentation or RGA instructions, or as otherwise reasonably required, to the manufacturer's address, together with (1) RGA number issued by manufacturer at Customer's request; (2) proof of purchase and, if necessary, proof of installation date; (3) a Return Goods Authorization Form; (4) a description of the suspected defects; (5) the serial number of the manufacturer product alleged to be defective; and (6) a description of the type of water and pretreatment equipment which has been utilized in connection with the product, if any. Manufacturer shall, in manufacturer's reasonable discretion, be the sole judge of whether a returned product or component is defective in material or workmanship. Required or replaced products or components shall be returned surface freight. In genuine emergency situations, manufacturer will (at manufacturer's sole discretion) forward replacement parts to Customer without waiting for authorized return of the questionable part(s). In such cases, Customer will issue a purchase order or other payment guarantee prior to shipment. If the returned part is found to have been misused or abused, or the defective part is not received by manufacturer within thirty (30) days; the Customer will be invoiced for the replacement part(s) provided. This Warranty does not cover or include labor and/or travel to the Customer's premise or location or any other location. Charges of \$1000 per day plus associated travel expenses will be incurred by the Customer in providing the Warranty Service at any location other than manufacturer's main headquarters; that is if manufacturer deems that the product is not covered by said Warranty. Manufacturer reserves the right to precondition such travel to Customer's premises upon prepayment of manufacturer's anticipated costs of attending such premises.

Voidability of Warranty

This Warranty shall be void and unenforceable as to any manufacturer product which has been damaged by accident, mishandling, abuse or has been repaired, modified, altered, disassembled or otherwise tampered with by anyone other than manufacturer or an authorized manufacturer service representative; or, if any replacement parts are not authorized by manufacturer have been used, or, the product has not been installed, operated and maintained in strict accordance and adherence with the operating documentation and manuals for such product. Any expressed warranty, or similar representation of performance set forth in the operation documentation for media or resin incorporated into a manufacturer product shall be void and unenforceable unless the feed water requirements set forth in the operating documentation for such product are unequivocally and strictly adhered to.

Limitations and Exclusions

THIS WARRANTY AND REMEDIES DESCRIBED HEREIN AND HEREINABOVE ARE EXCLUSIVE AND IN LIEU OF ANY AND ALL OTHER WARRANTY OR REMEDIES, EXPRESSED OR IMPLIED, INCLUDING WITHOUT LIMITATION, ANY IMPLIED WARRANTY OF MERCHANTABILITY OR FITNESS FOR A PARTICULAR PURPOSE. IN NO EVENT SHALL THE MANUFACTURER BE LIABLE FOR ANY CONSEQUENTIAL, INCIDENTAL OR OTHER SIMILAR TYPES OF DAMAGES, FOR DAMAGES FOR THE LOSS OF PRODUCTION OR PROFITS, OR INJURY TO PERSON OR PROPERTY. NO PERSON HAS ANY AUTHORITY TO BIND THE MANUFACTURER TO OTHER THAN WHAT IS SET FORTH ABOVE. THIS WARRANTY GIVES THE CUSTOMER SPECIFIC LEGAL RIGHTS AND THE CUSTOMER MAY ALSO HAVE OTHER RIGHTS WHICH VARY FROM JURISDICTION TO JURISDICTION. THE PARTIES RECOGNIZE AND AGREE, THAT IN ALL RESPECTS THE LAWS OF THE STATE OF CALIFORNIA SHALL APPLY TO AND SHALL GOVERN ANY INTERPRETATION OR LEGAL SIGNIFICANCE OF THIS DOCUMENT. NO WARRANTY OR OTHER LIABILITY OF MANUFACTURER TO CUSTOMER UNDER THIS AGREEMENT OR OTHERWISE WILL IN ANY EVENT EXCEED THE COST OF REPLACEMENT OF THE APPLICABLE MANUFACTURER PRODUCT, PART, OR ACCESSORY THAT IS SUBJECT TO ANY BREACH OF MANUFACTURER'S WARRANTY. MANUFACTURER WILL NOT BE LIABLE FOR ANY DAMAGE TO ANY PROPERTY OF CUSTOMER OR TO CUSTOMER'S CUSTOMERS FOR ANY CONSEQUENTIAL, INCIDENTAL, OR ECONOMIC LOSS OR COMMERCIAL DAMAGE WHATSOEVER. REMEDIES HEREIN PROVIDED ARE EXPRESSLY MADE THE SOLE AND EXCLUSIVE REMEDIES FOR BREACH OF ANY WARRANTY OR OTHER OBLIGATION HEREUNDER EXPRESS OR IMPLIED OR FROM THE OPERATION OF LAW.